



MultiServicerXD
MI 3325
Instruction manual
Ver. 1.6.10, Code no. 20 752 877

Distributor:

Manufacturer:

Metrel d.o.o.
Ljubljanska cesta 77
SI-1354 Horjul
[e-mail:info@metrel.si](mailto:info@metrel.si)
<https://www.metrel.si>

DATA BACKUP AND LOSS:

It is the user's responsibility to ensure the integrity and security of the data carrier and to regularly backup and validate the integrity of backups of the data. METREL HAS NO OBLIGATION OR LIABILITY FOR ANY LOSS, ALTERATION, DESTRUCTION, DAMAGE, CORRUPTION OR RECOVERY OF USER DATA, REGARDLESS OF WHERE THE DATA IS STORED.



Mark on your equipment certifies that it meets requirements of all subjected EU regulations.



Hereby, Metrel d.o.o. declares that the MI 3325 is in compliance with Directive 2014/53/EU (RED) and all other subjected EU directive. The full text of the EU declaration of conformity is available at the following internet address <https://www.metrel.si/DoC>.



Mark on your equipment certifies that it meets requirements of all subjected UK regulations.



Hereby, Metrel d.o.o. declares that the MI 3325 is in compliance with Radio Equipment Regulations 2017 and all other subjected UK regulations. The full text of the UK declaration of conformity is available at the following internet address <https://www.metrel.si/UK-DoC>.

© Metrel d.o.o.

Published: 08/2023

The trade names Metrel®, Smartec®, Eurotest®, Auto Sequence® are trademarks registered in Europe and other countries.

No part of this publication may be reproduced or utilized in any form or by any means without permission in writing from METREL.

i. About the instruction manual

- › This Instruction manual contains detailed information on the MultiServicerXD, its key features, functionalities and use.
- › It is intended for technically qualified personnel responsible for the product and its use.
- › Please note that LCD screenshots in this document may differ from the actual instrument screens in details due to firmware variations and modifications.
- › *Metrel* reserve the right to make technical modifications without notice as part of the further development of the product.

TABLE OF CONTENTS

1	General description.....	10
1.1	Warnings and notes	10
1.1.1	Safety warnings.....	10
1.1.2	Warnings related to safety of measurement functions	11
1.1.2.1	HV AC, HV AC programmable.....	11
1.1.2.2	Differential leak., Ipe leak., Touch leak., Power, Leak's & Power.....	11
1.1.2.3	Insulation resistance.....	11
1.1.2.4	Continuity functions (Rlow, Continuity)	11
1.1.3	Notes related to measurement functions	12
1.1.4	Markings on the instrument	13
1.2	Testing potential on TP1-PE terminal for installation tests.....	15
1.3	Standards applied	15
2	Instrument set and accessories	18
2.1	Standard set of the instrument	18
2.2	Optional accessories.....	18
3	Instrument description.....	19
3.1	Front panel.....	19
4	Instrument operation	21
4.1	General meaning of keys	21
4.2	General meaning of touch gestures:.....	21
4.3	Virtual keyboard	22
4.4	Safety checks.....	22
4.5	Symbols and messages	23
4.5.1	Warning messages.....	23
4.5.2	Measurement actions and messages	26
4.5.3	Result indication	27
4.5.4	Auto Sequence® result indication.....	29
4.5.5	Terminal voltage monitor	29
4.5.6	Bluetooth indication	30
4.6	Instrument main menu.....	30
4.7	General settings.....	31
4.7.1	Language	32
4.7.2	Date and time	32
4.7.3	Settings	33
4.7.3.1	RCD standard	36
4.7.3.2	EV RCD/RCM standards.....	37
4.7.4	Change password for HV functions	38
4.7.5	Bluetooth initialization	38
4.7.6	Initial Settings	38
4.7.7	About.....	39
4.8	User Accounts.....	40
4.8.1	Signing in	40
4.8.2	Changing user password, signing out.....	41
4.8.3	Managing accounts	42
4.8.4	Setting Blackbox password.....	43
4.8.5	Edit user accounts	44
4.9	Devices	46

4.10	Instrument profiles.....	47
4.11	Workspace Manager	47
4.11.1	Workspaces and Exports.....	48
4.11.2	Workspace Manager main menu	48
4.11.2.1	Operations with Workspaces	49
4.11.2.2	Operations with Exports	49
4.11.2.3	Adding a new Workspace.....	50
4.11.2.4	Opening a Workspace.....	50
4.11.2.5	Deleting a Workspace / Export	51
4.11.2.6	Importing a Workspace.....	52
4.11.2.7	Exporting a Workspace	52
4.12	Auto Sequence® groups	53
4.12.1	Auto Sequence® groups menu.....	53
4.12.1.1	Operations in Auto Sequence® groups menu:.....	54
4.12.1.2	Selecting a group of Auto Sequences®.....	54
4.12.1.3	Deleting a group of Auto Sequences®.....	55
5	Memory Organizer.....	56
5.1	Memory Organizer menu.....	56
5.1.1	Measurement statuses	56
5.1.2	Structure Objects.....	57
5.1.2.1	Measurement status indication under the Structure object	57
5.1.3	Selecting an active Workspace in Memory Organizer.....	58
5.1.4	Adding Nodes in Memory Organizer	59
5.1.5	Operations in Tree Menu	60
5.1.5.1	Operations on measurements (finished or empty measurements).....	60
5.1.5.2	Operations on Structure objects	61
5.1.5.3	View / Edit parameters and attachments of a Structure object.....	62
5.1.5.4	Custom lists of Structure parameter values	64
5.1.5.5	Add a new Structure Object.....	65
5.1.5.6	Add a new measurement.....	66
5.1.5.7	Clone a Structure object.....	68
5.1.5.8	Clone a measurement	69
5.1.5.9	Copy & Paste a Structure object.....	70
5.1.5.10	Cloning and Pasting sub-elements of selected structure object.....	71
5.1.5.11	Copy & Paste a measurement.....	71
5.1.5.12	Cut & Paste a Structure object with sub-items	72
5.1.5.13	Delete a Structure object	73
5.1.5.14	Delete a measurement	73
5.1.5.15	Rename a Structure object.....	74
5.1.5.16	Recall and Retest selected measurement	75
5.1.6	Searching in Memory Organizer	76
6	Single tests.....	79
6.1	Selection of single test	79
6.1.1	Single test screens	80
6.1.1.1	Single test start screen.....	80
6.1.1.2	Setting parameters, limits and comments of single tests	81
6.1.1.3	Single test screen during test	83
6.1.1.4	Single test result screen	84
6.1.1.5	Single test memory screen	85
6.1.2	Single test (inspection) screens	85
6.1.2.1	Single test (inspection) start screen.....	86
6.1.2.2	Single test (Inspection) screen during test.....	87
6.1.2.3	Single test (Inspection) result screen.....	88

6.1.2.4	Single test (inspection) memory screen.....	89
6.1.3	Help screens	89
6.2	Single test measurements	90
6.2.1	Visual inspection.....	90
6.2.2	Continuity	91
6.2.2.1	Compensation of test leads resistance (Continuity, PE conductor (PRCD))... 93	
6.2.2.2	Limit Calculator	94
6.2.3	Insulation resistance RPAT (Portable appliance).....	96
6.2.4	Insulation resistance R_w (Welding equipment)	98
6.2.5	Insulation resistance ISO (Installations).....	99
6.2.5.1	Load pretest	101
6.2.6	Varistor test	101
6.2.7	Sub-leakage (I_{sub} , I_{sub-S})	104
6.2.8	Differential Leakage.....	105
6.2.9	I_{pe} Leakage.....	106
6.2.10	Touch Leakage.....	108
6.2.11	Welding Circuit Leakage I_{leak} (W-PE).....	109
6.2.12	Protective conductor current I_{primW}	110
6.2.13	Leak's & Power.....	111
6.2.14	Power	113
6.2.15	Voltage, frequency and phase sequence.....	114
6.2.16	Z loop – Fault loop impedance and prospective fault current	118
6.2.17	Z loop $m\Omega$ – High precision fault loop impedance and prospective fault current	119
6.2.18	Zs rcd – Fault loop impedance and prospective fault current in system with RCD	122
6.2.19	Z line – Line impedance and prospective short-circuit current.....	124
6.2.20	Z line $m\Omega$ – High precision line impedance and prospective short-circuit current	126
6.2.21	High Current (MI 3143 and MI 3144)	129
6.2.22	Z auto - Auto test sequence for fast line and loop testing.....	130
6.2.23	Voltage Drop	132
6.2.24	U touch – Touch voltage (MI 3143 and MI 3144)	135
6.2.25	R line $m\Omega$ – DC resistance measurement (MI 3144).....	136
6.2.26	ELR Current Injection Test (MI 3144)	138
6.2.27	ELR Combination Time Test (MI 3144).....	139
6.2.28	Current Clamp Meter (MI 3144)	141
6.2.29	EVSE Diagnostic Test (A 1632).....	142
6.2.30	R_{pe} – PE conductor resistance	144
6.2.31	R_{low} – Resistance of earth connection and equipotential bonding	145
6.2.31.1	Compensation of test leads resistance (R_{low}).....	147
6.2.32	PRCD test (A 1322, A 1422).....	147
6.2.33	PE conductor (PRCD)	149
6.2.34	RCD U_c – Contact voltage.....	150
6.2.35	RCD t – Trip-out time.....	152
6.2.36	RCD I – Trip-out current	154
6.2.37	RCD Auto – RCD Auto test.....	157
6.2.38	HV AC	159
6.2.39	HV AC programmable	161
6.2.40	Polarity	163
6.2.41	Clamp current.....	165
6.2.42	No-load voltage (A 1422).....	166
6.2.43	Discharging time.....	167
6.2.44	Measurements using adapter MD 9273	169
6.2.44.1	Power CLAMP	170

6.2.44.2	Voltage CLAMP	171
6.2.44.3	Current CLAMP	172
6.2.44.4	Inrush CLAMP	173
6.2.44.5	Harmonics U CLAMP	175
6.2.44.6	Harmonics I CLAMP	177
6.2.45	Functional inspection	178
7	Auto Sequences®	180
7.1	Selection of Auto Sequence®.....	180
7.1.1	Selecting an active Auto Sequence® group in Auto Sequences® menu.....	180
7.1.2	Searching in Auto Sequences® menu	181
7.1.3	Organization of Auto Sequences® in Auto Sequences® menu.....	182
7.2	Organization of an Auto Sequence®	183
7.2.1	Auto Sequence® view menu	183
7.2.1.1	Auto Sequence® view menu (Header is selected).....	184
7.2.1.2	Auto Sequence® view menu (measurement is selected).....	184
7.2.1.3	Auto Sequence® Configurator menu	185
7.2.1.4	Indication of Loops	186
7.2.1.5	Managing multiple points.....	186
7.2.2	Step by step execution of Auto Sequences®	187
7.2.3	Auto Sequence® result screen	188
7.2.4	Auto Sequence® memory screen	190
8	Communications	192
8.1	USB and RS232 communication with PC	192
8.2	Bluetooth communication	192
8.3	Bluetooth communication with printers and scanners	193
8.4	RS232 communication with other external devices	193
8.5	Ethernet communication.....	193
8.6	Communication with adapters	193
8.7	Connections to test adapters.....	194
8.7.1	Active 3 Phase Adapter /Plus (A 1322 / A 1422).....	194
8.7.2	Euro Z 290A adapter A 1143	195
8.7.3	Euro Z 440 V / 800 V instrument (MI 3143, MI 3144)	195
8.7.4	eMobility Analyser (A 1632).....	195
8.7.5	Leakage clamp meter with Bluetooth® communication (MD 9273)	196
8.7.6	CE Adapter A 1460.....	196
8.8	INPUTS.....	196
8.9	OUTPUTS.....	197
8.9.1	Warning lamps	197
9	Upgrading the instrument.....	198
10	Maintenance	199
10.1	Periodic calibration.....	199
10.2	Fuses	199
10.3	Service.....	199
10.4	Cleaning.....	199
11	Technical specifications	200
11.1	HV AC, HV AC programmable	200
11.2	Continuity	200
11.3	Insulation Resistance Rpat (Riso, Riso-S).....	201
11.4	Sub-Leakage Current, Substitute Leakage Current - S.....	201
11.5	Differential Leakage current	202
11.6	PE leakage current.....	202

11.7	Touch leakage current.....	202
11.8	Power.....	203
11.9	Leak's & Power	204
11.10	PRCD.....	206
11.11	PE conductor (PRCD)	206
11.12	RCD testing.....	206
11.12.1	RCD U _c – Contact voltage.....	207
11.12.2	RCD t – Trip-out time.....	208
11.12.3	RCD I – Trip-out current	208
11.12.4	RCD Auto	209
11.13	Polarity.....	209
11.14	Clamp current.....	209
11.15	Insulation resistance Riso (welding equipment).....	210
11.16	Welding Circuit leakage (I _{leak W-PE}).....	210
11.17	Primary Leakage (I _{diff}).....	210
11.18	No-load voltage.....	210
11.19	Voltage, frequency, and phase rotation	210
11.19.1	Phase rotation	210
11.19.2	Voltage	211
11.19.3	Frequency	211
11.19.4	Online terminal voltage monitor	211
11.20	Insulation resistance ISO (Installations).....	211
11.21	Varistor test.....	212
11.22	R _{low} - Resistance of earth connection and equipotential bonding.....	212
11.23	Z _{loop} – Fault loop impedance and prospective fault current.....	213
11.24	Z _{s rcd} – Fault loop impedance and prospective fault current in system with RCD ...	214
11.25	Z _{line} – Line impedance and prospective short-circuit current	214
11.26	Z _{auto}	215
11.27	Z _{line} mΩ	215
11.28	Z _{loop} mΩ	215
11.29	High current	215
11.30	R _{line} mΩ - DC resistance measurement	215
11.31	ELR Current injection	216
11.32	ELR Combination time test.....	216
11.33	U _{touch} – Touch voltage	216
11.34	Current clamp meter.....	216
11.35	EVSE Diagnostic test	216
11.36	Power CLAMP.....	216
11.37	Voltage CLAMP.....	216
11.38	Current CLAMP	216
11.39	Inrush CLAMP.....	216
11.40	Harmonics U CLAMP	217
11.41	Harmonics I CLAMP.....	217
11.42	Voltage Drop	217
11.43	Discharging time	217
11.44	R _{pe} – PE conductor resistance	218
11.45	General data	219
Appendix A	Structure objects in MultiServicerXD.....	221
Appendix B	Profile Notes	222
B.1	Profile Austria (AUAF).....	222
B.2	Profile Hungary (AUAE)	223
B.3	Profile Finland (AUAG).....	224
B.4	Profile UK (AUAB).....	224

B.5	Profile AUS (AUAD)	226
Appendix C	Print labels and write / read RFID/NFC tags.....	229
C.1	PAT tag format	229
C.2	Generic tag format	231
Appendix D	Default list of Auto Sequences®	233
Appendix E	Programming of Auto Sequences® on Metrel ES Manager.....	234
E.1	Auto Sequence® editor workspace.....	234
E.2	Managing groups of Auto Sequences®	235
E.2.1	Auto Sequence® Name, Description and Image editing	237
E.2.2	Search within selected Auto Sequence® group	237
E.3	Elements of an Auto Sequence®	238
E.3.1	Auto Sequence® steps	238
E.3.2	Single tests	238
E.3.3	Flow commands	239
E.3.4	Number of measurement steps.....	239
E.4	Creating / modifying an Auto Sequence®	239
E.5	Description of flow commands.....	240
E.6	Custom Inspections programming	244
E.6.1	Creating and editing Custom Inspections	244
E.6.2	Applying Custom Inspections.....	246

1 General description

1.1 Warnings and notes



1.1.1 Safety warnings

In order to reach high level of operator safety while carrying out various measurements using the MultiServicerXD instrument, as well as to keep the test equipment undamaged, it is necessary to consider the following general warnings:

- › **Read this Instruction manual carefully, otherwise use of the instrument may be dangerous for the operator, for the instrument, or for the application equipment of the instrument!**
- › **Consider warning markings on the instrument!**
- › **If the test equipment is used in manner not specified in this Instruction manual the protection provided by the equipment may be impaired!**
- › **Do not use the instrument and accessories if any damage is noticed!**
- › **Regularly check the instrument and accessories for correct functioning to avoid hazard that could occur from misleading results!**
- › **Consider all generally known precautions in order to avoid risk of electric shock while dealing with hazardous voltages!**
- › **All normal safety precautions have to be taken in order to avoid risk of electric shock when working on electrical installations!**
- › **Use only standard or optional test accessories declared for this instrument and supplied by your distributor!**
- › **Only test equipment provided or approved by Metrel should be connected to test and communication connectors.**
- › **Only correctly earthed mains socket outlets shall be used to supply the instrument!**
- › **In case a fuse has blown refer to chapter 10.2 Fuses to replace it!**
- › **Calibration, adjustment, and repairing of the instrument is allowed to be carried out only by a competent authorized person!**
- › **Do not connect external voltage to CLAMP inputs. It is intended only for connection of Clamps approved by Metrel.**
- › **Metrel Auto Sequences® are designed as guidance to tests in order to significantly reduce testing time, improve work scope and increase traceability of the tests performed. METREL assumes no responsibility for any Auto Sequence®**

by any means. It is the user's responsibility, to check adequacy for the purpose of use of the selected Auto Sequence®. This includes type and number of tests, sequence flow, test parameters and limits!

1.1.2 Warnings related to safety of measurement functions

1.1.2.1 HV AC, HV AC programmable

- › A dangerous voltage up to 5 kV a.c. is applied to the HV instrument outputs during the test. Therefore, special safety consideration must be taken when performing this test!
- › Only a skilled person familiar with hazardous voltages can perform this measurement!
- › DO NOT perform this test if any damage or abnormality (test leads, instrument) is noted!
- › Never touch exposed probe tip, connections equipment under test or any other energized part during the measurements. Make sure that NOBODY can contact them either!
- › DO NOT touch any part of test probe in front of the barrier (keep your fingers behind the finger guards on the probe) – possible danger of electric shock!
- › It is a good practice to use lowest possible trip-out current.

1.1.2.2 Differential leak., Ipe leak., Touch leak., Power, Leak's & Power

- › Load currents higher than 10 A can result in high temperatures of fuse holders! It is advisable not to run tested devices with load currents above 10 A for more than 15 minutes. Recovery period for cooling is required before proceeding with tests! Maximum intermittent duty cycle for measurements with load currents higher than 10 A is 50 %.

1.1.2.3 Insulation resistance

- › Insulation resistance measurement should only be performed on de-energized objects!
- › Do not touch the test object during the measurement and until it is fully discharged! Risk of electric shock!

1.1.2.4 Continuity functions (Rlow, Continuity)

- › Continuity measurement should only be performed on de-energized objects!

1.1.3 Notes related to measurement functions

Insulation resistance (Riso)

- If a voltage of higher than 30 V (AC or DC) is detected between TP1 test terminals, the measurement will not be performed.
- Load pretest detects possible connection of appliances to the system during test. Test eliminates possible damage to the equipment that could be connected to the system during Insulation resistance measurements.
- Load pretest is carried out between same terminals on TP1 as the Insulation resistance measurement.

R low

- If a voltage of higher than 10 V (AC or DC) is detected between TP1 test terminals, the measurement will not be performed.
- Parallel loops may influence on test results.
- In some kind of PRCDs types (PRCD-3p and PRCD-S+), the protective conductor is monitored. For protective conductor resistance measurement, a test current of 200 mA is required. Direct application will cause tripping of PRCD, so PE conductor measurement is not possible.

In this case use a test parameter **Current** set to '**ramp**', where special ramp curve is used for PE conductor resistance measurement without tripping of PRCD. If **Current** parameter is set to '**normal**', a standard test current curve is used.

RCD t, RCD I, RCD Uc, RCD Auto

- RCD t and RCD I measurements will only be performed if the contact voltage in the pre-test at nominal differential current is lower than the set contact voltage limit!
- Parameters set in one function are also kept for other RCD functions!
- Selective (time-delayed) RCDs have delayed response characteristics. As the contact voltage pre-test or other RCD tests influence the time delayed RCD it takes a certain period to recover into normal state. Therefore, a time delay of 30 s is inserted before performing trip-out test by default.
- Trip-out times, trip-out currents and contact voltage limits of Portable RCDs (PRCD, PRCD-2p, PRCD-3p, PRCD-S, PRCD-S+ and PRCD-K) are equal to limits of general (non-delayed) RCDs.
- In some kind of PRCDs types (PRCD, PRCD-3p, PRCD-S+ and PRCD-K), the protective conductor is monitored and carried out in the opposite direction through current sensor circuitry. During periodic testing – when fault current flows through phase and protective conductor – this can cause misunderstanding, because PRCD reacts at half the tripping fault current. In order to prevent this, use parameter **Sensitivity** set to '**Ipe monitoring**', where test current will be a half of selected nominal tripping current.
- If **Sensitivity** parameter is set to '**standard**', a test current with nominal tripping current is used.
- The a.c. part of MI and EV RCDs is tested as general (non-delayed) RCDs.
- The d.c. part of MI and EV RCDs is tested with a d. c. test current The Pass limit is between 0.5 and 1.0 I_{dNDC} .
- The Zs rcd function takes longer to complete but offers much better accuracy of fault loop resistance (in comparison to the R_L sub-result in Contact voltage function).
- Auto test is finished without x5 tests in case of testing the RCD types A, F, B and B+ with rated residual currents of $I_{dN} = 300$ mA, 500 mA, and 1000 mA or testing the RCD type AC with rated residual current of $I_{dN} = 1000$ mA. In this case Auto test result passes if all other results pass, and indications for x5 are omitted.
- Auto test is finished without x1 tests in case of testing the RCD types B and B+ with rated residual currents of $I_{dN} = 1000$ mA. In this case Auto test result passes if all other results pass, and indications for x1 are omitted.
- Tests for sensitivity $I_{dn}(+)$ and $I_{dn}(-)$ are omitted for selective type RCD.

- › Trip out time measurement for B and B+ type RCDs in AUTO function is made with sine-wave test current, while trip-out current measurement is made with DC test current.

Z loop, Zs rcd

- › The specified accuracy of tested parameters is valid only if the mains voltage is stable during the measurement.
- › The measurement accuracy and immunity against noise are higher if **I test** parameter in Zsrcd is set to 'Standard'.
- › Fault loop impedance (Z loop) measurements will trip an RCD.
- › The Zs rcd measurement does not normally trip an RCD. However, if a leakage current from L to PE already flows or if a very sensitive RCD is installed (for example EV type) the RCD could trip. In this case setting parameter **I test** to 'Low' can help.

Z line, Voltage drop

- › In case of measurement of $Z_{\text{Line-Line}}$ with the instrument test leads PE and N connected together the instrument will display a warning of dangerous PE voltage. The measurement will be performed anyway.
- › Specified accuracy of tested parameters is valid only if mains voltage is stable during the measurement.
- › If the reference impedance is not set the value of Z_{REF} is considered as 0.00Ω .
- › The lowest value of Zref, measured at different settings of the **Test** or **Phase** parameters is used for Voltage drop (ΔU) measurement in Voltage drop single test, Zauto single test and Auto Sequences®.
- › Measuring Zref without test voltage present (disconnected test leads) will reset Zref value to initial value.

Rpe

- › The specified accuracy of tested parameters is valid only if the mains voltage is stable during the measurement.
- › Measurement will trip an RCD if the parameter RCD is set to 'No'.
- › The measurement does not normally trip an RCD if the parameter RCD is set to 'Yes'. However, the RCD can trip if a leakage current from L to PE already flows.

Z line m Ω , Z loop m Ω

- › MI 3143 Euro Z 440 V, MI 3144 Euro Z 800 V or A 1143 Euro Z 290 A adapter is required for these measurements.

Z auto

- › See notes related to Zline, Zloop, Zs rcd and Voltage drop single tests.

Auto Sequences®

- › Auto Sequences® mode allows building custom-defined test sequences.
- › See notes related to single tests in the selected Auto Sequence®.
- › Compensate test leads resistance before entering Auto Sequences®.
- › Zref value for Voltage drop test (ΔU) implemented in any Auto Sequence® should be set in single test function.

1.1.4 Markings on the instrument

- ›  **Read the Instruction manual with special care to safety operation«. The symbol requires an action!**

- ›  Dangerous high voltage is present on terminals during the test. Consider all precautions in order to avoid risk of electric shock.



- › Do not use in distribution systems with voltages higher than 440 V.

- ›  Mark on your equipment certifies that this equipment meets requirements of all subjected EU regulations.

- ›  Mark on your equipment certifies that this equipment meets requirements of all subjected UK regulations.



- ›  This equipment shall be recycled as electronic waste.

1.2 Testing potential on TP1-PE terminal for installation tests

In certain instances, faults on the installation's PE wire or any other accessible metal bonding parts can become exposed to live voltage. This is a very dangerous situation since the parts connected to the earthing system are considered to be free of potential. The instrument checks the voltage between mains PE and PE terminal of TP1 connector.

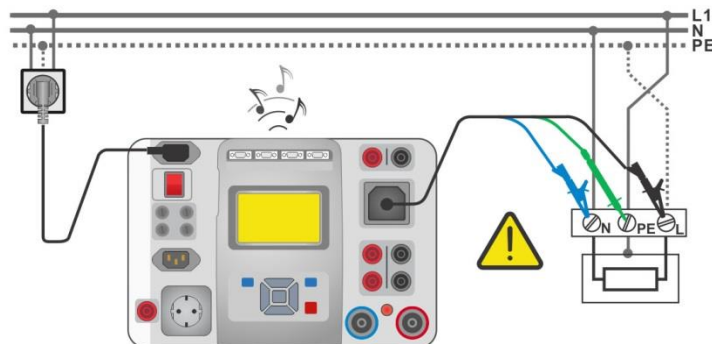



Figure 1.1: Reversed L and PE conductors (application of 3-wire test lead)

Warnings!

- › **Reversed line and PE conductors is the most dangerous situation!**
- › **If dangerous voltage is detected on TP1-PE terminal, stop all measurements immediately and ensure the cause of the fault is eliminated before proceeding with any activity!**

Test procedure

- › Connect test cable to the instrument.
- › Connect test leads to the object under test.
- › Test is automatically done after entering appropriate test function¹⁾

If hazardous live voltage is detected between mains PE and PE terminal of TP1 connector and three-phase rotary field is not detected, instrument displays warning icon , display is yellow coloured, instrument buzzer is activated and further measurements are disabled: RCD tests, Rpe, Z loop, Zs rcd, Z auto, Voltage drop ΔU and Auto Sequences[®].

Notes:

- › ¹⁾The test on TP1-PE terminal is active in the Voltage, Rpe, RCD tests, Z loop, Zs rcd, Z auto, Z line, ΔU and Auto Sequences only!
- › Make sure that the power supply socket for MI 3325 is properly grounded. PE test could otherwise be impaired and results of a single test or Auto Sequence[®] can mislead.

1.3 Standards applied

The MultiServicerXD instrument is manufactured and tested according to the following regulations, listed below.

Electromagnetic compatibility (EMC)

EN 61326-1	Electrical equipment for measurement, control and laboratory use - EMC requirements – Part 1: General requirements
------------	--

Safety (LVD)

EN 61010-1	Safety requirements for electrical equipment for measurement, control, and laboratory use – Part 1: General requirements
EN 61010-2-030	Safety requirements for electrical equipment for measurement, control and laboratory use – Part 2-030: Particular requirements for testing and measuring circuits
EN 61010-031	Safety requirements for electrical equipment for measurement, control and laboratory use – Part 031: Safety requirements for hand-held probe assemblies for electrical measurement and test
EN 61010-2-032	Safety requirements for electrical equipment for measurement, control and laboratory use – Part 2-032: Particular requirements for hand-held and hand-manipulated current sensors for electrical test and measurement
EN 61557	Electrical safety in low voltage distribution systems up to 1 000 V a.c. and 1 500 V d.c. – Equipment for testing, measuring or monitoring of protective measures Instrument complies with all relevant parts of EN 61557 standards.

Functionality

EN 61557	Electrical safety in low voltage distribution systems up to 1 000 V a.c. and 1 500 V d.c. – Equipment for testing, measuring or monitoring of protective measures Instrument complies with all relevant parts of EN 61557 standards.
EN 50191	Erection and operation of electrical test equipment
IET Code of Practice	Household and similar electrical appliances
NEN 3140	Operation of electrical installations – Low voltage
IEC/EN 60974-4	Arc welding equipment – Part 4: Periodic inspection and testing
AS/NZS 3760	In-service safety inspection and testing of electrical equipment
IEC/EN 61439	Low-voltage switchgear and controlgear assemblies
IEC/EN 60204-1	Safety of machinery - Electrical equipment of machines
IEC 62368-1	Audio/video, information and communication technology equipment – Part 1: Safety requirements
EN 61180	High-voltage test techniques for low-voltage equipment - Definitions, test and procedure requirements, test equipment
EN 50699 (VDE 0702)	Recurrent Test of Electrical Equipment
EN 50678 (VDE 0701)	General procedure for verifying the effectiveness of the protective measures of electrical equipment after repair

Reference standards for electrical installations and components

EN 61008-1	Residual current operated circuit-breakers without integral overcurrent protection for household and similar uses (RCCBs) - Part 1: General rules
EN 61009-1	Residual current operated circuit-breakers with integral overcurrent protection for household and similar uses (RCBOs) - Part 1: General rules
IEC 60364-4-41	Electrical installations of buildings Part 4-41 Protection for safety – protection against electric shock
BS 7671	IEE Wiring Regulations (18 th edition)
AS/NZS 3017	Electrical installations – Verification guidelines
IEC 62752	In-cable control and protection device for mode 2 charging of electric road vehicles (IC-CPD)
IEC 62955	Residual direct current detecting device (RDC-DD) to be used for mode 3 charging of electric vehicles

2 Instrument set and accessories

2.1 Standard set of the instrument

- › Instrument MI 3325 MultiServicerXD
- › Bag for accessories
- › HV test lead, 2 pcs, 2 m
- › HV crocodile clip, 2 pcs
- › Continuity test lead, 2 pcs, 2.5 m
- › Test lead 2.5 mm², 1.5 m, (red)
- › Residual voltage cable, 2 m
- › 3-wire test lead, 3 x 3 m
- › Test probe, 4 pcs, (black, blue, green, red)
- › Crocodile clip, 3 pcs, (black)
- › Mains cable, 3 x 1.5 mm², 2 m
- › USB cable
- › RS-232 cable
- › CD includes:
 - PC software Metrel ES Manager
 - Instruction manual
- › Quick guide
- › Calibration Certificate

2.2 Optional accessories

See the attached sheet for a list of optional accessories that are available on request from your distributor.

3 Instrument description

3.1 Front panel

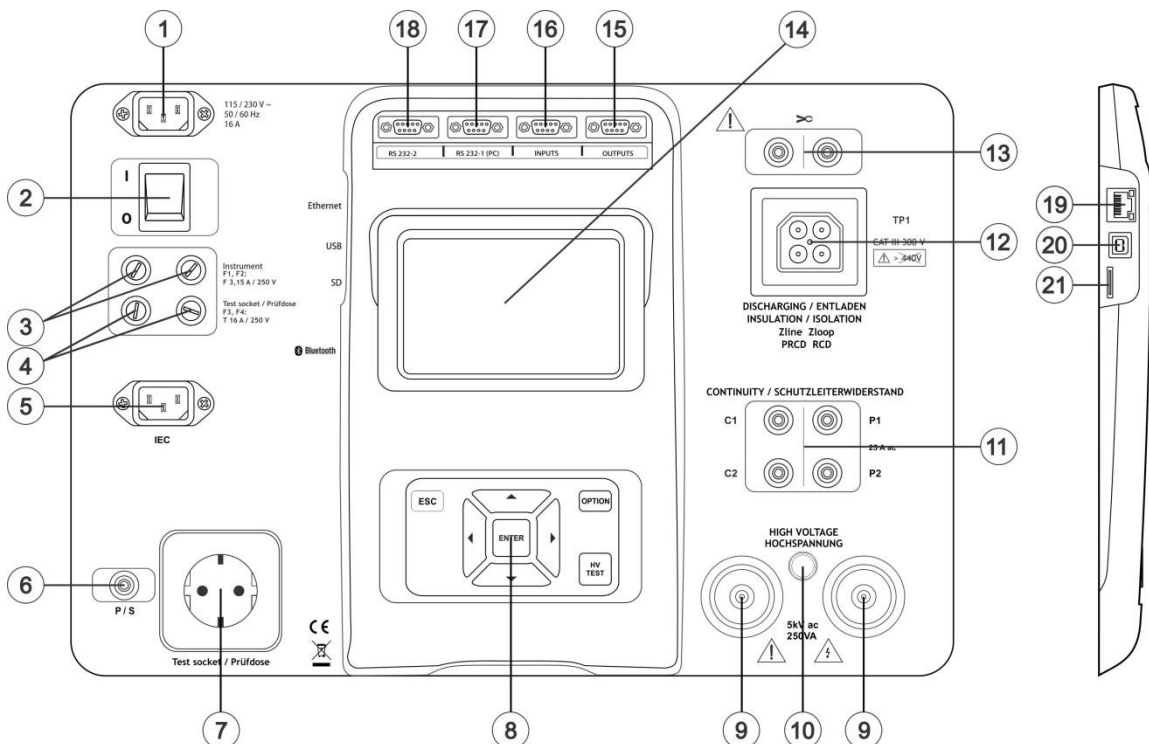

Figure 3.1: Front panel

1	Mains supply connector
2	On / Off switch
3	F1, F2 fuses (F 3.15 A / 250 V)
4	F3, F4 fuses (T 16 A / 250 V)
5	IEC test socket
6	P/S (probe) connector
7	Mains test socket
	Warning!
	<ul style="list-style-type: none"> Line voltage is present on the test socket during the measurement. Maximum output current is 16 A, test only devices with maximum rated supply current no higher than 16 A!
	Note:
	<ul style="list-style-type: none"> For devices incorporating high reactive loading, e.g. motor with rated active power >1.5 kW, it is recommended to start measurement first and to turn on the tested device later.
8	Keypad
9	HV output connectors
10	HV output warning lamp
11	Continuity connectors
12	Test connector TP1

13 Current clamp connectors**Warning!**

- Do not connect any voltage source on this input. It is intended only for connection of current clamp with current output. Maximum input current is 30 mA!

14 Colour TFT display with touch screen

15 Control outputs

16 Control inputs

17 Multipurpose RS232-1 port

18 Multipurpose RS232-2 port

19 Ethernet connector

20 USB connector

21 MicroSD card slot

Note:

- The instrument contains dedicated connectors intended to be connected only to dedicated accessories provided or approved by Metrel.

4 Instrument operation

The instrument can be manipulated via a keypad or touch screen.

4.1 General meaning of keys



Cursor keys are used to:

- › select appropriate option



Enter key is used to:

- › confirm selected option
- › start and stop measurements



Escape key is used to:

- › return to previous menu without changes
- › abort measurements



Option key is used to:

- › expand column in control panel
- › show detailed view of options



HV Start key is used to:

- › start and stop HV tests

4.2 General meaning of touch gestures:



Tap (briefly touch surface with fingertip) is used to:

- › select appropriate option
- › confirm selected option
- › start and stop measurements



Swipe (press, move, lift) up/ down is used to:

- › scroll content in same level
- › navigate between views in same level



long

Long press (touch surface with fingertip for at least 1 s) is used to:

- › select additional keys (virtual keyboard)



Tap Escape icon is used to:

- › return to previous menu without changes;
- › abort measurements

4.3 Virtual keyboard



Figure 4.1: Virtual keyboard

Options:

shift	Toggle case between lowercase and capital letters. Active only when keyboard layout with alphabetical characters is selected.
←	Backspace Clears last character or all characters if selected. (If held for 2 s, all characters are selected).
↵	Enter confirms new text.
12#	Activates numeric / symbols layout.
ABC	Activates alphabetic characters.
eng	English keyboard layout.
GR	Greek keyboard layout.
RU	Russian keyboard layout.
HEB	Hebrew keyboard layout.
↶	Returns to the previous menu without changes.

4.4 Safety checks

At start up and during operation, the instrument performs various safety checks to ensure safety and to prevent any damage. These safety pre-tests are checking for:

- › Correct input mains voltage
- › Presence of input PE connection,
- › Any external voltage against earth on mains test socket,
- › Excessive leakage currents through measuring I/O's,

- › Excessive load current through measuring I/O's,
- › Too low resistance between L and N of tested device,
- › Proper operation of safety relevant internal electronic circuits,
- › Presence of dangerous voltage on PE terminal of TP1 connector.

If a safety check fails, an appropriate warning message will be displayed and safety measures will be taken. The warnings and safety measures are described in chapter **4.5 Symbols and messages**.

4.5 Symbols and messages

4.5.1 Warning messages

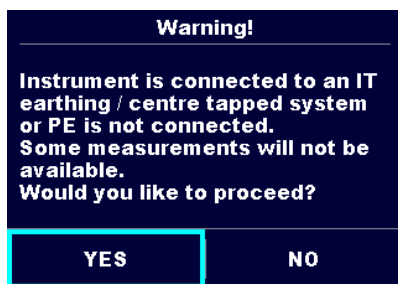

Supply voltage warning

Possible causes:

- › No earth connection.
- › Instrument is connected to an IT earthing system. Press YES to continue normally or NO to continue in a limited mode (measurements are disabled).

Warning:

The instrument must be earthed properly to work safely!

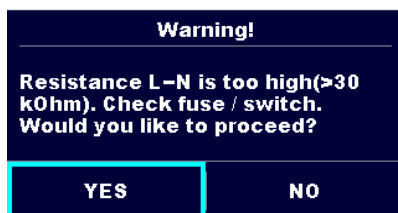

Resistance L-N > 30 kΩ

In pre-test a high input resistance was measured.

Possible causes:

- › Device under test is not connected or switched on
- › Input fuse of device under test is blown.

Select **YES** to proceed with or **NO** to cancel measurement.

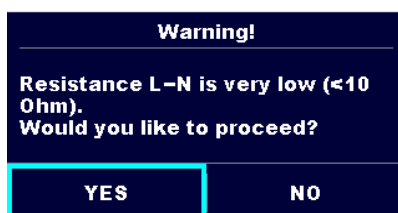

Resistance L-N < 10 Ω

In pre-test a very low resistance of the device under test supply input was measured. This can result in a high current after applying power to the device under test. If the too high current is only of short duration (caused by a short inrush current), the test can be performed otherwise not.

Select **YES** to proceed with or **NO** to cancel measurement.

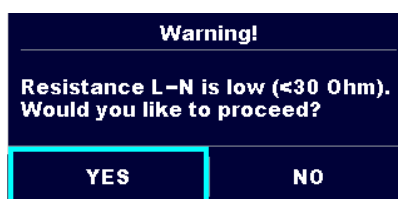

Resistance L-N < 30 Ω

In pre-test a low input resistance of the device under test was measured. This can result in a high current after applying power to the device. If the high current is only of short duration (caused by a short inrush current) the test can be performed, otherwise not.

Select **YES** to proceed with or **NO** to cancel measurement.

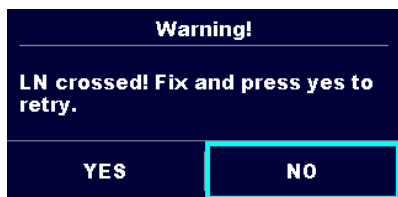

Warning for proper connection in PE conductor measurements. Connection of PRCD's plug must be changed in order to proceed.

Select **YES** to retry after reconnection with or **NO** to cancel measurement.

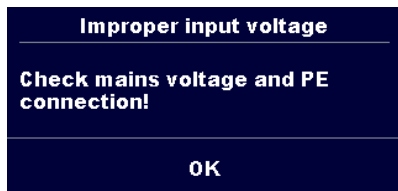

Warning for improper supply voltage condition. If pressing OK instrument will continue to work in a limited mode (measurements are disabled).

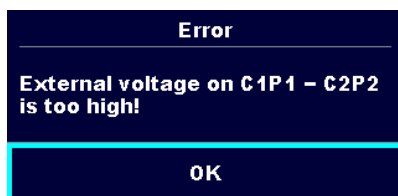

In pre-test an external voltage between C1/P1 and C2/P2 terminals was detected. The measurement was cancelled. Press **OK** to continue.

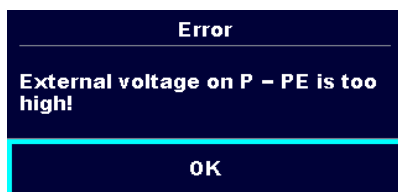

In pre-test a too high external voltage was detected between P and PE terminals. The measurement was cancelled. Press **OK** to continue.

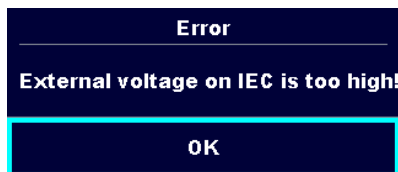

In pre-test a too high external voltage was detected between IEC test socket and PE terminal. The measurement was cancelled. Press **OK** to continue.

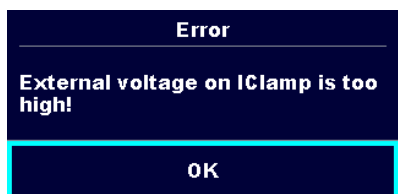

In pre-test a too high external voltage was detected between Current Clamp and PE terminals. The measurement was cancelled. Press **OK** to continue.

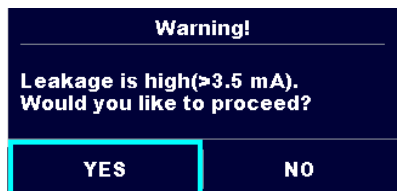

In pre-test a possible high leakage current was detected. It is likely that a dangerous leakage current (higher than 3.5 mA) will flow after applying power to the device under test.

Select **YES** to proceed with or **NO** to cancel measurement.

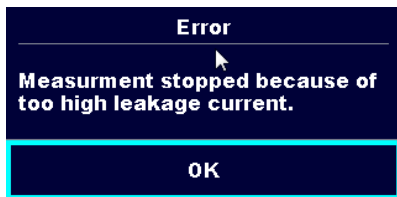

The measured leakage (I_{diff}, I_{pe}, I_{touch}) current was higher than 20 mA. Measurement was aborted. Press OK to continue.

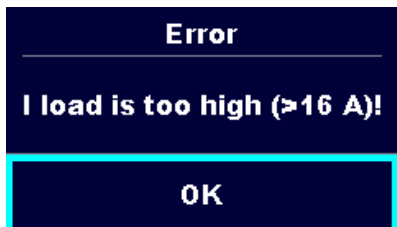

The load current higher than 16 A is detected. Measurement is aborted. Press OK to continue.

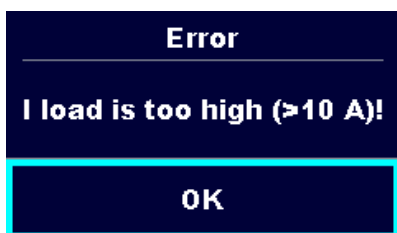

The average load current higher than 10 A over the last 5 min test interval is detected. Measurement is stopped. Recovery period for cooling is required before proceeding with tests! Press OK to continue.

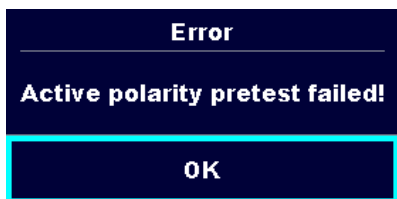

The polarity pre-test of the cable / PRCD has failed. Press OK to continue.

Yellow screen and activated buzzer sound!

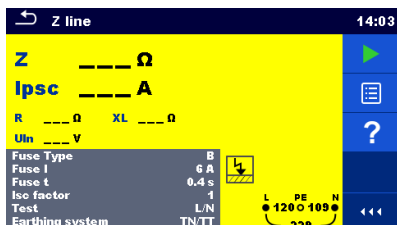















Hazardous live voltage on TP1-PE input is present before running RCD tests, R_{pe}, Z loop, Z_{s rcd}, Z auto, Voltage drop ΔU and Auto Sequences®.

Warning!

- › **Immediately disconnect supply from tested installation / equipment and check and correct PE wiring!**

4.5.2 Measurement actions and messages

	Conditions on the input terminals allow starting the measurement; consider other displayed warnings and messages.
	Conditions on the input terminals do not allow starting the measurement, consider displayed warnings and messages.
	Proceeds to next step of the measurement.
	Stop the measurement.
	Result(s) can be stored.
	Starts test leads compensation in Rlow / Continuity P/S - PE measurement. Starts Zref line impedance measurement at origin of electrical installation in Voltage Drop measurement. Zref value is set to 0.00 Ω if pressing this touch key while instrument is not connected to a voltage source.
	Expands column in control panel.
	The instrument is overheated. The measurement can't be carried out until the icon disappears. Press OK to continue.
	The device under test should be switched on (to ensure that the complete circuit is tested).
	In case of simultaneously measuring of Riso, Riso-S or Isub, Isub-S. If the voltage has dropped because of one measurement, the other measurement is also compromised.
	Measurement result Isub, Isub-S is scaled to 110 V.
	Test leads resistance in Rlow and Continuity P/S - PE measurement is not compensated.
	Test leads resistance in Rlow and Continuity P/S - PE measurement is compensated.
	Warning! A high voltage is / will be present on the instrument output! (Withstanding test voltage, Insulation test voltage, or mains voltage).
	Warning! Mains voltage is applied on Test socket! (Applicable in PRCD tests.)

**Warning!**

Instrument is connected to an IT earthing / centre tapped system or PE is not connected. DO NOT USE THE INSTRUMENT IF PE FAULT!

**Warning!**

A very high voltage is / will be present on the instrument output.



Warning! Dangerous voltage on TP1-PE input! Stop the activity immediately and eliminate the fault / connection problem before proceeding with any activity!

Continuous sound warning and yellow coloured screen is also present.



RCD tripped-out during the measurement (in RCD functions).



High electrical noise was detected during measurement. Results may be impaired.



L and N are changed.

In most instrument profiles L and N test terminals are reversed automatically according to detected voltages on input terminal. In instrument profiles for countries where the position of phase and neutral connector is defined the selected feature is not working.



Single fault condition in IT system.



Measurement can't be started. 3 phase adapter should be disconnected from the instrument.



Measurement in combination with appropriate 3 phase adapter can be carried out.



The measurement can be carried out only in combination with appropriate 3 phase adapter.



Use MI 3143 Euro Z 440 V, MI 3144 Euro Z 800 V or A 1143 Euro Z 290 A adapter for this test.



Measurement is running, consider displayed warnings.



Count down timer (in seconds) within measurement.

4.5.3 Result indication



Measurement result is inside the set limits (PASS).



Measurement result is outside the set limits (FAIL).



Measurement is aborted. Consider displayed warnings and messages.

4.5.4 Auto Sequence® result indication

	All Auto Sequence® results of single tests with the set limits are inside the set limits (PASS).
	At least one Auto Sequence® single test result with the set limits is outside the set limits (FAIL).
	All applied single tests in the Auto Sequence® are without the set limits and results without PASS / FAIL indication.
	All single tests in Auto Sequence® were skipped and/or aborted.
	Measurement result is inside the set limits (PASS).
	Measurement result is outside the set limits (FAIL).
	Measurement result without PASS / FAIL indication.
	Measurement not performed.

4.5.5 Terminal voltage monitor

The terminal voltage monitor displays on-line the voltages on the TP1 connector and information about active test terminals.

	Online voltages are displayed together with test terminal indication. All three test terminals are used for selected measurement.
	Online voltages are displayed together with test terminal indication. L and N test terminals are used for selected measurement.
	L and PE are active test terminals. N terminal should also be connected for correct input voltage condition.
	L and N are active test terminals. PE terminal should also be connected for correct input voltage condition.
	Polarity of test voltage applied to the output terminals, L and N.
	L and PE are active test terminals.
	Polarity of test voltage applied to the output terminals, L and PE.

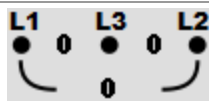

3-phase measurement terminal screen.

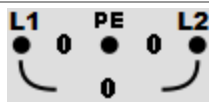

IT earthing system terminal indication.



Test terminals for Discharging time measurement.

4.5.6 Bluetooth indication



Bluetooth communication inactive.



Bluetooth communication active.

4.6 Instrument main menu

From the instrument Main Menu different main operation menus can be selected.

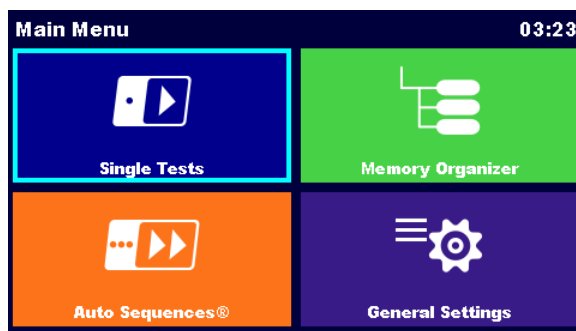

Figure 4.2: Main menu

Options



Single Tests

Menu with single tests, see chapter 6 *Single tests*.



Auto Sequences®

Menu with customized test sequences, see chapter 7 *Auto Sequences®*.



Memory Organizer

Menu for working with and documentation of test data, see chapter 5 *Memory Organizer*.



General Settings

Menu for setup of the instrument, see chapter **4.7 General settings**.

4.7 General settings

In the General Settings menu general parameters and settings of the instrument can be viewed or set.

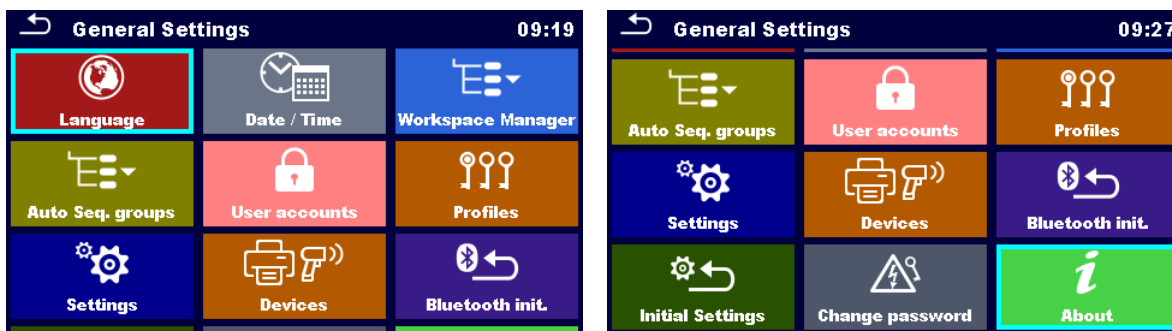

Figure 4.3: Setup menu

Options in General Settings menu



Language

Instrument language selection.



Date / Time

Instruments Date and time.



Workspace Manager

Manipulation with project files. Refer to chapter **4.11 Workspace Manager** for more information.



Auto Sequence® groups

Manipulation with lists of Auto Sequences®. Refer to chapter **4.12 Auto Sequence® groups** for more information.



User accounts

User settings. Refer to chapter **4.8 User Accounts** or more information.



Profiles

Selection of available instrument profiles. Refer to chapter **4.10 Instrument profiles** for more information.



Settings

Setting of different system / measuring parameters.



Devices

Selection of external devices. Refer to chapter **4.9 Devices** for more information.



Bluetooth initialization

Reset Bluetooth settings.



Initial Settings

Factory settings.



Change password

Changing password for enabling HV tests.



About

Basic instrument data.

4.7.1 Language

In this menu the language of the instrument can be set.



Figure 4.4: Select language menu

4.7.2 Date and time

In this menu date and time of the instrument can be set.

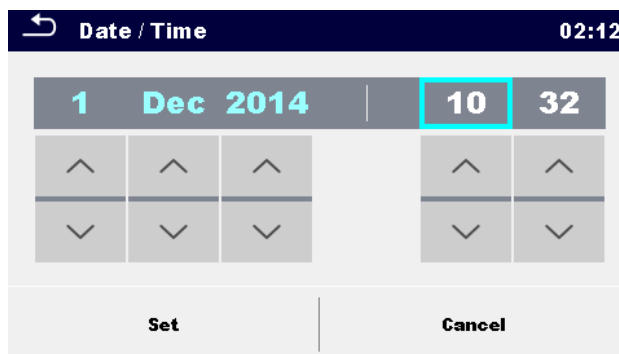

Figure 4.5: Setting date and time menu

4.7.3 Settings



Figure 4.6: Settings menu

Setting options:

Option	Description
Touch screen	ON – touch screen is active. OFF – touch screen is deactivated.
Keys & touch sound	ON – sound is active. OFF – sound is deactivated.
Equipment ID	Increment – offered ID will be incremented +1. Replicate – offered ID will be the same as last used. Blank – equipment ID will not be offered.
Equipment name	Replicate – offered name will be the same as last used. Blank – equipment name will not be offered.
Retest period	Replicate – offered retest period will be the same as last used. Blank – retest period will not be offered.
Ch_1 clamp type	Setting of current clamp type.
Earthing system	Terminal voltage monitor and measuring functions are suited to selected earthing system.
RCD standard	Select standard for RCD tests. Maximum RCD disconnection times differ in various standards. Refer to chapter 4.7.3.1 RCD standard for more information.
EV RCD/RCM Standards	Used standards for EV RCD, MI RCD and EV RCM tests. [IEC 62752, IEC 62955]
Isc factor	Short circuit current I_{sc} in the supply system is important for selection or verification of protective circuit breakers (fuses, over-current breaking devices, RCDs). The value should be set according to local regulative.
PRCD Standard	Selection of appropriate standard for PRCD tests.
Merge fuses	[Yes]: fuse type and parameters set in one function are also kept for other functions! [No]: Fuse parameters will be considered only in function where they have been set.
Result	In case the measurement consists of multiple measurements taken successively, the worst or the last result can be displayed. The setting applies to PAT measurements.

	<p>Worst – the worst result will be displayed at the end of test. Last – last result will be displayed at the end of test.</p> <p>Notes:</p> <ul style="list-style-type: none"> ▸ In general, the worst result(s) of the main result is considered. Sub-result(s) taken at the same time as the worst case of the main result are displayed. ▸ In the function Leak's & Power the worst case of Idiff and I touch are considered. The Power result measured at the time of worst Idiff is displayed. ▸ In the function Riso, Riso-S the worst case of Riso and Riso-S are considered. The Um result measured at the time of worst Riso is displayed. ▸ For the Power measurement the last result is considered regardless of the Result setting.
Test mode	<p>Standard – Visual inspections should be checked manually Expert - Visual inspections are automatically checked PASS.</p>
Auto seq. flow	<p>Ends if fail – Auto Sequence will end after first fail status of measurement / inspection is detected. Proceeding tests will be skipped. Proceeds if fail – Auto Sequence will proceed even if fail status of measurement / inspection is detected.</p>
Ignore PE warning (IT)	<p>[yes] – In IT earthing system the instrument will allow to start the selected measurement regardless of PE warning detection. [no] – In IT earthing system the instrument will block the selected measurement if PE warning is detected.</p>
Uc pretest (IT)	<p>Yes – In IT earthing system the instrument will inhibit the selected measurement if result exceed set Uc limit. No – In IT earthing system the instrument will present warning message, if result exceed set Uc limit; operator should confirm to proceed with selected measurement</p>
IscMax, IscMin calculation	<p>Yes – IscMax, IscMin calculation is enabled in Z line measurement No – IscMax, IscMin calculation is disabled in Z line measurement</p>
Load pretest	<p>ON – Load pretest is enabled in Riso measurement. OFF – Load pretest is disabled.</p>
Warning lamps	<p>None – Lamps off; (OUTPUTS terminal disabled in single tests). HV lamps – HV warning lamps enabled in HV single tests. (A 1496) HV lamps + status – HV warning lamps enabled in HV single tests and pass / fail status lamps enabled in all single tests. (A 1497)</p>
Pedal / Commander	<p>ON – Pedal or Commander enabled in single tests. OFF – Pedal or Commander disabled.</p>
Ext. Keyboard	<p>ON – enable external BT keyboard. (See A 1578 manual for details.) OFF – external BT keyboard is disabled.</p>
Limit Uc	<p>Conventional touch voltage limit [Custom, 12 V, 25 V, 50 V]</p>

Configuration of measuring adapters:

Option:	Available selection:	Description:
Adapter type	[None, selected adapter]	Selection from list of available adapters.
Port	[RS232, Bluetooth]	Sets communication port of selected measuring adapter. See chapter 8.6 Communication with adapters for details.
Bluetooth device name	Name of selected adapter	After searching is finished, list of all available Bluetooth devices is presented. Pair the instrument with selected measuring adapter.

Ethernet setting options:

Option:	Available selection:	Description:
Obtain an IP	[AUTOMATICALLY, MANUAL]	When the manual mode is chosen, the user must provide the correct network settings. Otherwise, the instrument is automatically assigned an IP address from the local network using the DHCP protocol.
IP address	XXX.XXX.XXX.XXX	Displays the instrument's IP address. In manual mode, the user should enter the correct value.
Port number	0 – 65535	Selects the port number on which the instrument listens for incoming connections. The instrument communicates using UDP/IP protocol. Max. UDP packet length is 1024 bytes.
Subnet mask	XXX.XXX.XXX.XXX	In manual mode, the user should enter the correct value.
Default gateway	XXX.XXX.XXX.XXX	In manual mode, depending on the network topology, the use can enter the correct value or leave it as it is, if not needed.
Preferred DNS server	XXX.XXX.XXX.XXX	In manual mode, depending on the network topology, the use can enter the correct value or leave it as it is, if not needed.
Alternate DNS server	XXX.XXX.XXX.XXX	In manual mode, depending on the network topology, the use can enter the correct value or leave it as it is, if not needed.
Host name	MI3325_XXXXXXXX	Displays the instrument's unique name on the local network. The host name consists of the instrument's name and its serial number.
MAC address	XX:XX:XX:XX:XX:XX	Displays the instrument's MAC address. User can change the address in case of another device on the network using the same value.

Note:

- Instrument will reset to apply new Ethernet settings (if modified).

4.7.3.1 RCD standard

Maximum RCD disconnection times differ in various standards. The trip-out times defined in individual standards are listed below.

	$\frac{1}{2} \times I_{\Delta N}^{(1)}$	$I_{\Delta N}$	$2 \times I_{\Delta N}$	$5 \times I_{\Delta N}$
General RCDs (non-delayed)	$t_{\Delta} > 300$ ms	$t_{\Delta} < 300$ ms	$t_{\Delta} < 150$ ms	$t_{\Delta} < 40$ ms
Selective RCDs (time-delayed)	$t_{\Delta} > 500$ ms	$130 \text{ ms} < t_{\Delta} < 500$ ms	$60 \text{ ms} < t_{\Delta} < 200$ ms	$50 \text{ ms} < t_{\Delta} < 150$ ms

Table 4.1: Trip-out times according to EN 61008 / EN 61009

Test according to standard IEC/HD 60364-4-41 has two selectable options:

- IEC 60364-4-41 TN/IT and
- IEC 60364-4-41 TT

The options differ to maximum disconnection times as defined in IEC/HD 60364-4-41 **Table 4.2**.

	$U_0^{(3)}$	$\frac{1}{2} \times I_{\Delta N}^{(1)}$	$I_{\Delta N}$	$2 \times I_{\Delta N}$	$5 \times I_{\Delta N}$
TN / IT	≤ 120 V	$t_{\Delta} > 800$ ms	$t_{\Delta} \leq 800$ ms	$t_{\Delta} < 150$ ms	$t_{\Delta} < 40$ ms
	≤ 230 V	$t_{\Delta} > 400$ ms	$t_{\Delta} \leq 400$ ms		
TT	≤ 120 V	$t_{\Delta} > 300$ ms	$t_{\Delta} \leq 300$ ms		
	≤ 230 V	$t_{\Delta} > 200$ ms	$t_{\Delta} \leq 200$ ms		

Table 4.2: Trip-out times according to IEC/HD 60364-4-41

	$\frac{1}{2} \times I_{\Delta N}^{(1)}$	$I_{\Delta N}$	$2 \times I_{\Delta N}$	$5 \times I_{\Delta N}$
General RCDs (non-delayed)	$t_{\Delta} > 1999$ ms	$t_{\Delta} < 300$ ms	$t_{\Delta} < 150$ ms	$t_{\Delta} < 40$ ms
Selective RCDs (time-delayed)	$t_{\Delta} > 1999$ ms	$130 \text{ ms} < t_{\Delta} < 500$ ms	$60 \text{ ms} < t_{\Delta} < 200$ ms	$50 \text{ ms} < t_{\Delta} < 150$ ms

Table 4.3: Trip-out times according to BS 7671

RCD type	$I_{\Delta N}$ (mA)	$\frac{1}{2} \times I_{\Delta N}^{(1)}$ t_{Δ}	$I_{\Delta N}$ t_{Δ}	$2 \times I_{\Delta N}$ t_{Δ}	$5 \times I_{\Delta N}$ t_{Δ}	Note
I	≤ 10		40 ms	40 ms	40 ms	Maximum break time
II	$> 10 \leq 30$	> 999 ms	300 ms	150 ms	40 ms	
III	> 30		300 ms	150 ms	40 ms	
IV S	> 30	> 999 ms	500 ms 130 ms	200 ms 60 ms	150 ms 50 ms	Minimum non-actuating time

Table 4.4: Trip-out times according to AS/NZS 3017⁽²⁾

Standard	$\frac{1}{2} \times I_{\Delta N}$	$I_{\Delta N}$	$2 \times I_{\Delta N}$	$5 \times I_{\Delta N}$
EN 61008 / EN 61009	300 ms	300 ms	150 ms	40 ms
IEC 60364-4-41	1000 ms	1000 ms	150 ms	40 ms
BS 7671	2000 ms	300 ms	150 ms	40 ms
AS/NZS 3017 (I, II, III)	1000 ms	1000 ms	150 ms	40 ms

Table 4.5: Maximum test times related to selected test current for general (non-delayed) RCD

Standard	$\frac{1}{2} \times I_{\Delta N}$	$I_{\Delta N}$	$2 \times I_{\Delta N}$	$5 \times I_{\Delta N}$
EN 61008 / EN 61009	500 ms	500 ms	200 ms	150 ms
IEC 60364-4-41	1000 ms	1000 ms	150 ms	40 ms
BS 7671	2000 ms	500 ms	200 ms	150 ms
AS/NZS 3017 (IV)	1000 ms	1000 ms	200 ms	150 ms

Table 4.6: Maximum test times related to selected test current for selective (time-delayed) RCD

¹⁾ Minimum test period for current of $\frac{1}{2} \times I_{\Delta N}$, RCD shall not trip-out.

²⁾ Test current and measurement accuracy correspond to AS/NZS 3017 requirements.

³⁾ U_0 is nominal U_{LPE} voltage.

Notes:

- › Trip-out limit times for PRCD, PRCD-2p, PRCD-3p, PRCD-K, PRCD-S and PRCD S+ are equal to General (non-delayed) RCDs.
- › The trip-out times of VDE 0664 are equal to trip-out times of EN 61008 / EN 61009.
- › The trip-out times of VDE 0100-410 TN/IT are equal to trip-out times of IEC 60364-4-41 TN/IT.
- › The trip-out times of VDE 0100-410 TT are equal to trip-out times of IEC 60364-4-41 TT.

4.7.3.2 EV RCD/RCM standards

Standard	6 mA ($1 \times I_{\Delta N}$)	60 mA ($10 \times I_{\Delta N}$)	200 mA ($33 \times I_{\Delta N}$)	300 mA ($50 \times I_{\Delta N}$)
IEC 62955¹⁾	< 10.0 s	< 300 ms	< 100 ms	×
IEC 62752²⁾	< 10.0 s	< 300 ms	×	< 40 ms

Table 4.7: Break times for d.c. residual currents

¹⁾ IEC 62955: Table 2 – Maximum values of break times for residual direct currents

²⁾ IEC 62752: Table 3 – Limit values of break time for smooth d.c. residual currents

Standard	30 mA ($1 \times I_{\Delta N}$)	60 mA ($2 \times I_{\Delta N}$)	150 mA ($5 \times I_{\Delta N}$)
IEC 62752³⁾	< 300 ms	< 150 ms	< 40 ms

Table 4.8: Break times for a.c. residual currents

³⁾ IEC 62752: Table 2 – Limit values of break time for a.c. residual currents at rated frequency

Standard	Up to 30 mA ($1 \times I_{\Delta N}$)	60 mA ($2 \times I_{\Delta N}$)	150 mA ($5 \times I_{\Delta N}$)
IEC 62955⁴⁾	No tripping	> 300 ms	> 80 ms

Table 4.9: Non-operating times for a.c. residual currents

⁴⁾ IEC 62955: Table 3 – Minimum values of non-operating time for alternating residual currents (RMS values)

4.7.4 Change password for HV functions

In this menu the password to enable starting of HV functions can be set, changed or disabled.



Figure 4.7: Change password menu

Notes:

- › **Default password is 0000.**
- › An empty entry disables the password.
- › If password is lost, entry 4648 resets password to default.

4.7.5 Bluetooth initialization

In this menu the Bluetooth module is reset.

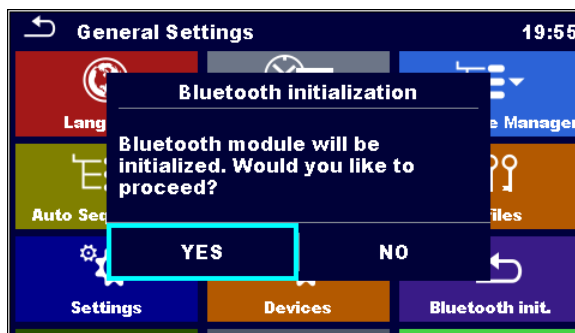

Figure 4.8: Bluetooth initialization menu

4.7.6 Initial Settings

With this menu, the instrument settings are set to the default factory settings. This also affects to measurement parameters and limits, also the Bluetooth device will be initialized.

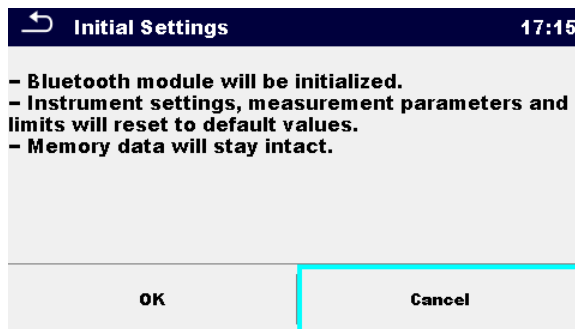

Figure 4.9: Initial settings menu

Warning!

Following customized settings will be lost when setting the instruments to initial settings:

- › Measurement limits and parameters
- › Global parameters, System settings and Devices in General settings menu
- › Opened Workspace and Auto Sequence® group will be deselected.
- › User will be signed out.

Note:

Following customized settings remain:

- › Profile settings
- › Data in memory (Data in Memory organizer, Workspaces, Auto Sequence® groups and Auto Sequences®)
- › User accounts
- › Password for HV functions

4.7.7 About

In this menu instrument data (name, serial number, firmware (FW) and hardware (HW) version, FW profile, hardware documentation (HD) version, fuse version and date of calibration) can be viewed.

About		10:17
Name	MI 3325 MultiServicerXD	
S/N	21190504	
FW version	1.2.25.b88c8764	
FW Profile	AUAA	
HW version	2	
HD version	3	

Figure 4.10: Instrument info screen

Note:

- › Adapter info is also displayed, if connected.

4.8 User Accounts

The instrument has ability to operate in unprotected or in password protected mode. With password protected mode, only registered users can use the instrument as intended.

Owner of the instrument decides about general privileges of using and operation with the instrument, see chapter **4.8.3 Managing accounts**. The administrator can only manage user accounts.

In case of applied privileges for using and operating with the instrument, the following listed activities are possible:

- Sign-in for working with the instrument, see chapter **4.8.1 Signing in**.
- Sign-out or changing password, see chapter **4.8.2 Changing user password, signing out**,
- Manage accounts, see chapter **4.8.3 Managing accounts**,
- Set Black-box operation, see chapter **4.8.4 Setting Blackbox password**, and
- Edit user account, see chapter **4.8.5 Edit user accounts**.

If a user account is set and the user is signed in, the user's name will be stored in memory for each measurement.

4.8.1 Signing in

By selecting User Accounts icon in Settings menu, Sign in menu appear on the screen. Same screen appears when instrument is switched on, if Sign in is set to required, see Chapter **4.8.3 Managing accounts** for details.

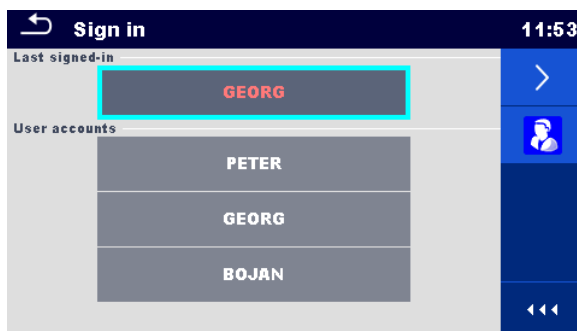

Figure 4.11: Sign in menu

Options

User signing in:



Last signed in user is highlighted and displayed in the first row.



Another user can be selected from the User accounts list.



Enters User password entry screen.

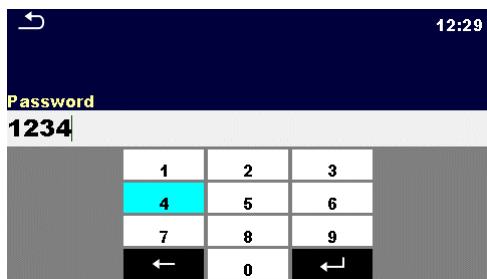

Enter the User password through the on-screen numerical keyboard and confirm .

User profile screen is opened as presented on **Figure 4.12**.

Administrator signing in:



Enters Account manager password entry screen.

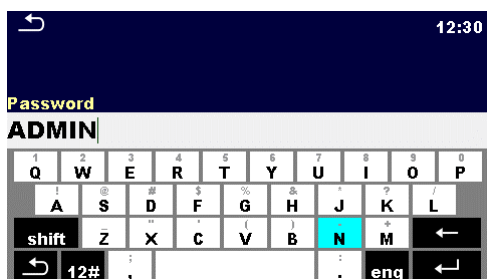

Enter the Administrator password through on-screen keyboard and confirm .

Account manager screen is opened as presented on **Figure 4.13**.

4.8.2 Changing user password, signing out

After user completed Sign in procedure, User profile menu screen is presented. Same screen is presented if signed in user selects User accounts from General Settings menu.

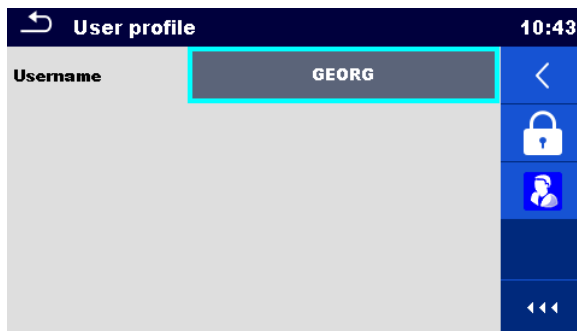

Figure 4.12: User profile menu

Options



Signed in user is displayed and highlighted on the top of the screen.



Sign out current user.
Sign in screen appear, see Chapter **4.8.1 Signing in** for details.



Enters Account manager password entry screen, see Chapter **4.8.1 Signing in** for details.



Change User password.
Numerical user password entry keyboard appear on the screen.

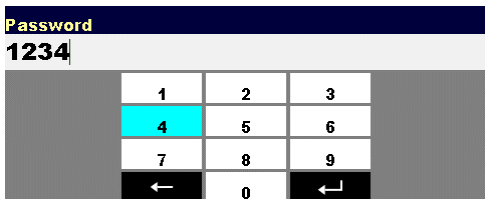

First step: enter current user password and confirm entry.

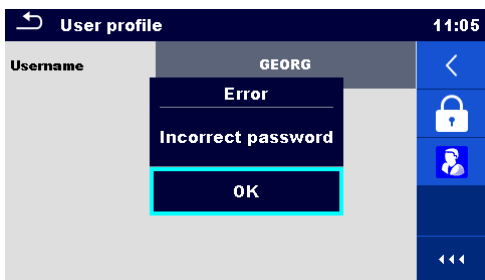

Wrong entry is reported by message. Confirm message, clear wrong password and repeat first step.

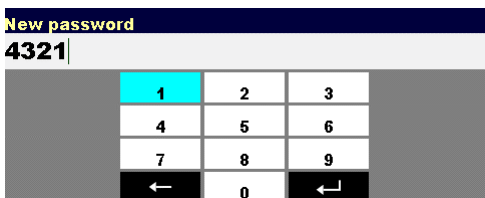

Second step: enter new user password and confirm entry. Password change is confirmed with short message appearance.

4.8.3 Managing accounts

Only the administrator has the possibility to manage users' accounts. User account password consists of an up to 4-digit number. The administrator password consists of an up to 15 characters. Factory set administrator password is ADMIN. To access Account manager menu, Administrator should be signed in, see Chapter **4.8.1 Signing in** for details. Administrator can set sign in requirement, change Administrator password and edit user accounts. Appearance of Account manager screen depends on previous settings, see **Figure 4.13** below.

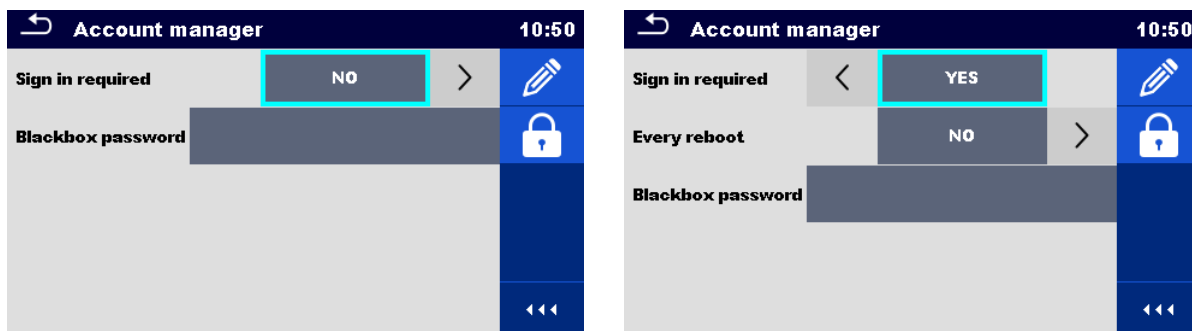

Figure 4.13: Account manager menu

Options



User sign in is not required.



User sign in is required. Presented setting requires sign in, when instrument is switched on. Sign in could also be set to required, on every restart of instrument.



Change Administrator password. Alphanumerical keyboard appears on the screen.

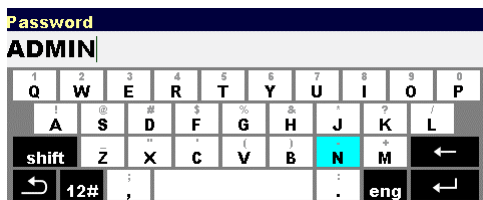

First step: enter current Administrator password and confirm entry.

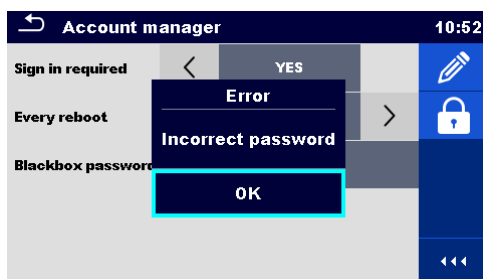

Wrong entry is reported by message. Confirm message, clear wrong password and repeat first step.

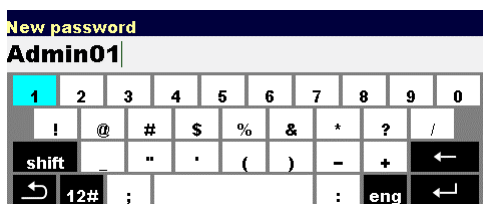

Second step: enter new Administrator password and confirm entry. Password change is confirmed with short message appearance.

Account manager screen appear again. Administrator can continue to manage accounts or returns to Settings and Main menu.



Edit account icon. Enter Edit accounts screen, presented on **Figure 4.14**. For details see Chapter **4.8.5 Edit user accounts**.

Note:

- If the password is forgotten the second administrator password can be used. This password always unlocks the Account manager and is delivered with the instrument.

4.8.4 Setting Blackbox password

Blackbox password can be set by administrator from the Account manager menu. Set Blackbox password is valid for all users. Default Blackbox password is empty (disabled).

Options

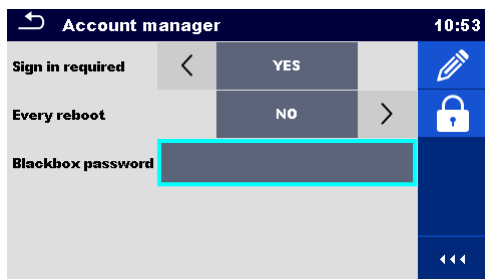

Add or edit Blackbox password. Enter to modify.

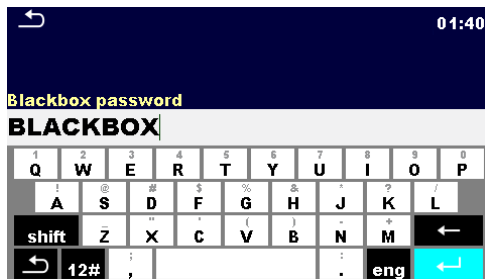

Keyboard for entering new Blackbox password is opened. Empty string disables password. Confirm entry.

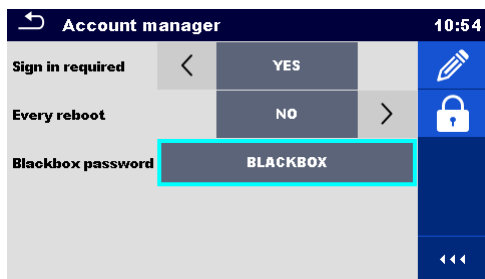

Blackbox password is changed.

4.8.5 Edit user accounts

Administrator can add new user and set his password, change user existing password, delete user account and delete all user accounts. Edit accounts screen is accessed by selecting Edit account icon from Account manager options screen, see Chapter 4.8.3 *Managing accounts*.

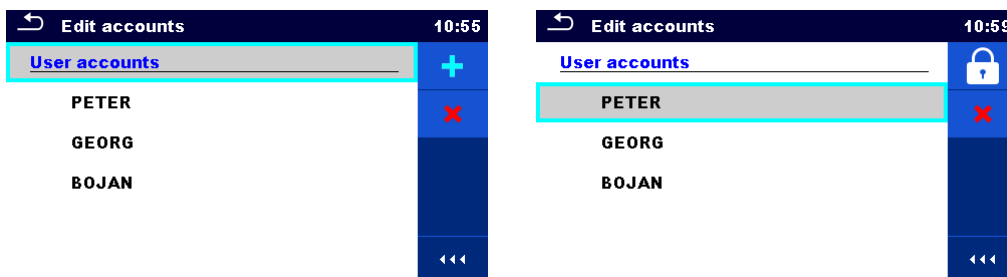
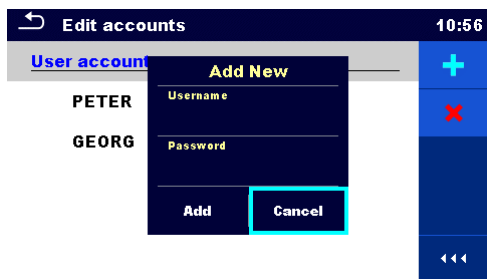

Figure 4.14: Edit accounts screen – user list on the left, user selected on the right

Options: User accounts User accounts is selected:



Add New user account.
Add New menu appear on the screen.



Add New selection options:

- › Username opens onscreen alphanumerical keyboard for new user name entry
- › Password opens onscreen numerical keyboard for new user password entry
- › Add stores new user to User account list.
- › Cancel interrupts procedure

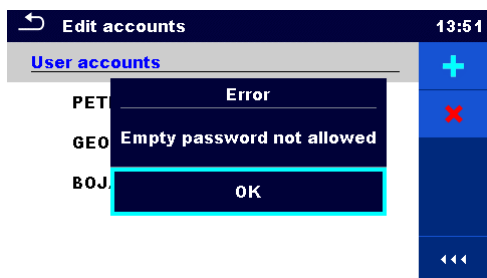

New user account password must be entered; if not, warning message appears on the screen.



Delete all user accounts. Warning message appears on the screen.

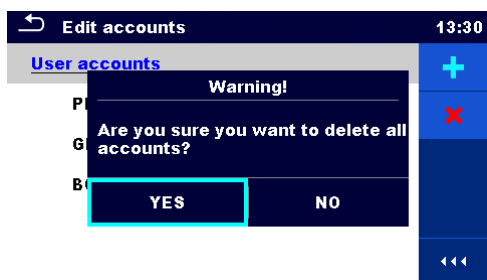

Warning message selection options:

- › YES: confirmation of deletion, all user accounts will be deleted
- › NO: interrupts procedure and return to Edit accounts menu

Options: User selected (user is highlighted PETER):



Set password
For selected user, password is set, numerical keyboard appears on the screen.

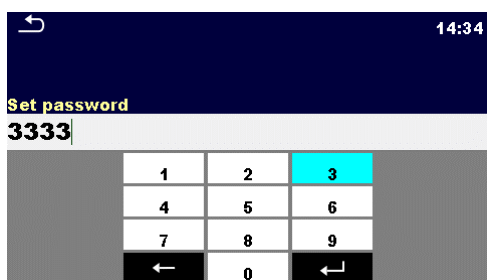

Enter user password and confirm entry.

Old user password is automatically overwritten without warning or confirmation.



Delete selected user account. Warning message appears on the screen.

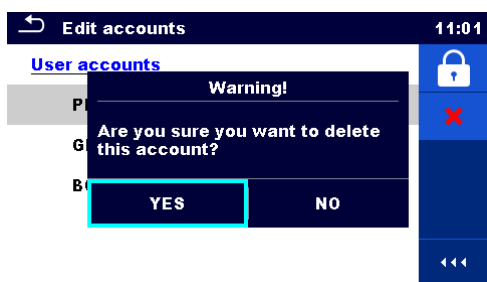

Warning message selection options:

- YES: confirmation of deletion, selected user account will be deleted
- NO: interrupts procedure and return to Edit accounts menu

4.9 Devices

In this menu operation with external devices is configured.

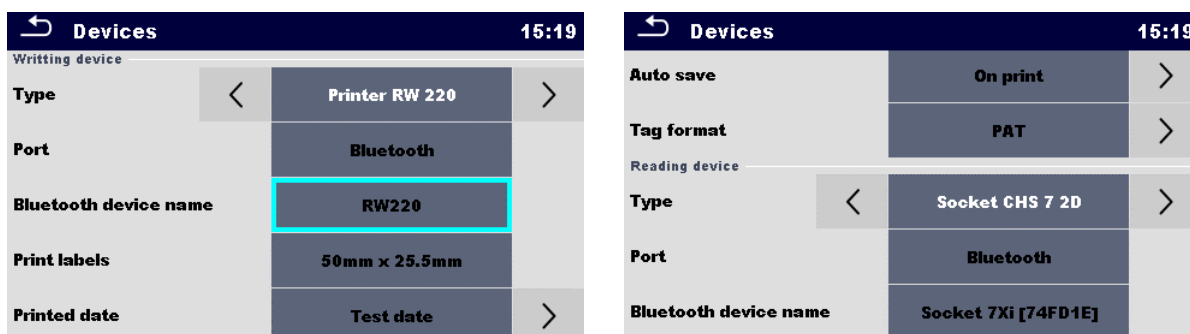

Figure 4.15: Devices settings menu

Writing devices	
Type	Sets appropriate writing device (Serial printer, Bluetooth printer), RFID writer).
Port	Sets/views communication port of selected writing device.
Bluetooth device name	Goes to menu for pairing with selected Bluetooth device.
Bluetooth dongle	Initializes Bluetooth Dongle.
Print labels	Selects label form size. See Appendix C Print labels and write / read RFID/NFC tags for details.
Printed date	Selects date printed on label text area, Test date or Retest date. See Appendix C Print labels and write / read RFID/NFC tags for details.
Auto save	Sets simultaneous saving of finished Auto Sequence when label is printed. See chapter 7.2.3 Auto Sequence® result screen for details.
Tag format	Sets PAT tag / label format or generic tag /label format. See Appendix C Print labels and write / read RFID/NFC tags for details.
Tag type	Selects tag type to be printed, Options: [simple, classic, QR] See Appendix C Print labels and write / read RFID/NFC tags for details.
Tags	Selects number of tags, Options: [1 tag, 2 tags] See Appendix C Print labels and write / read RFID/NFC tags for details.

Reading devices	
------------------------	--

Type	Sets appropriate reading device (QR or barcode scanner, RFID reader, android device via aMESM application).
Port	Sets/views communication port of selected reading device.
Bluetooth device name	Goes to menu for pairing with selected Bluetooth device.

4.10 Instrument profiles

The instrument uses different specific system and measuring settings in regard to the scope of work or country it is used. These specific settings are stored in instrument profiles. By default, each instrument has at least one profile activated. Proper licence keys must be obtained to add more profiles to the instruments. If different profiles are available, they can be selected in this menu.

Refer to **Appendix B Profile Notes** for more information about functions specified by profiles.

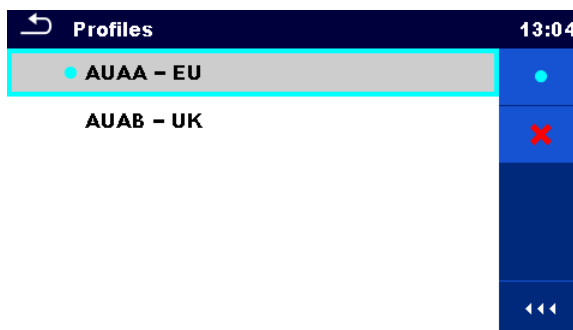

Figure 4.16: Instrument profile menu

Options



Loads the selected profile. The instrument will restart automatically with new profile loaded.



Enters option for deleting a profile.

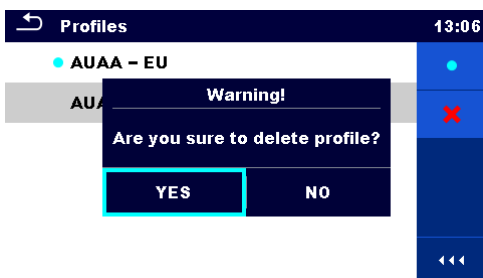

Before deleting the selected profile, user is asked for confirmation.

4.11 Workspace Manager

The Workspace Manager is intended to manage with different Workspaces and Exports stored on the microSD card.

4.11.1 Workspaces and Exports

The works with MultiServicerXD MI 3325 can be organized with help of Workspaces and Exports. Exports and Workspaces contain all relevant data (measurements, parameters, limits, structure objects) of an individual work.

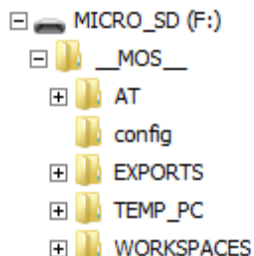

Figure 4.17: Organization of Workspaces and Exports on microSD card

Workspaces are stored on microSD card on directory WORKSPACES, while Exports are stored on directory EXPORTS. Exports are suitable for making backups of important works or can be used for storage of works if the removable microSD card is used as a mass storage device. To work on the instrument an Export should be imported first from the list of Exports and converted to a Workspace. To be stored as Export data a Workspace should be exported first from the list of Workspaces and converted to an Export.

4.11.2 Workspace Manager main menu

In Workspace manager Workspaces and Exports are displayed in two separated lists.

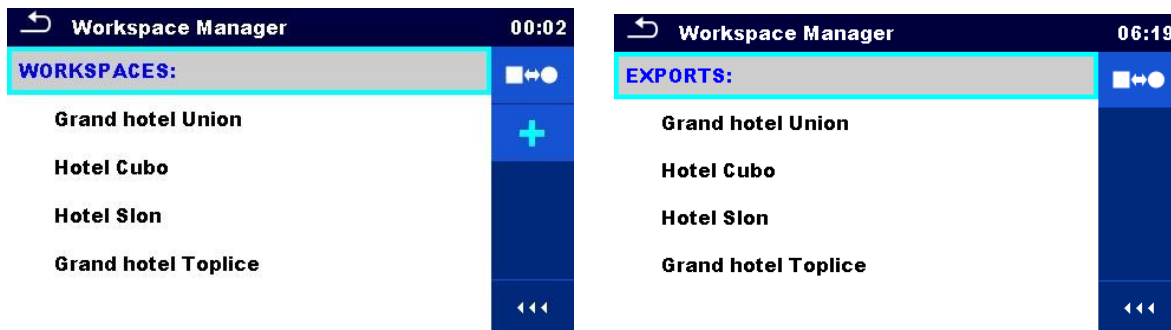

Figure 4.18: Workspace manager main menu

Options

	List of Workspaces.
	Displays a list of Exports
	Adds a new Workspace. Refer to chapter 4.11.2.3 <i>Adding a new Workspace</i> for more information.
	List of Exports.



Displays a list of Workspaces.

4.11.2.1 Operations with Workspaces

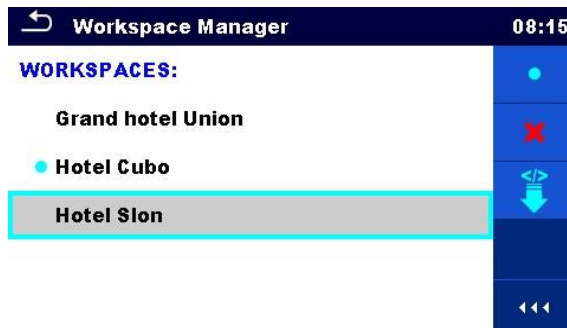

Figure 4.19: Workspace manager menu – Workspace selected

Only one Workspace can be opened in the instrument at the same time. The Workspace selected and marked in the Workspace Manager will be opened in the Memory Organizer.

Options



Marks the opened Workspace in Memory Organizer.
 Opens the selected Workspace in Memory Organizer.
 Refer to chapters **5 Memory Organizer** and **4.11.2.4 Opening a Workspace** for more information.



Deletes the selected Workspace.
 Refer to chapter **4.11.2.5 Deleting a Workspace / Export** for more information.



Exports a Workspace to an Export
 Refer to chapter **4.11.2.7 Exporting a Workspace** for more information.

4.11.2.2 Operations with Exports



Figure 4.20: Workspace manager Exports menu

Options



Deletes the selected Export.
Refer to chapter **4.11.2.5 Deleting a Workspace / Export** for more information.



Imports a new Workspace from Export
Refer to chapter **4.11.2.6 Importing a Workspace** for more information.

4.11.2.3 Adding a new Workspace



New workspaces can be added from the Workspace manager screen.



Enters option for adding a new Workspace.

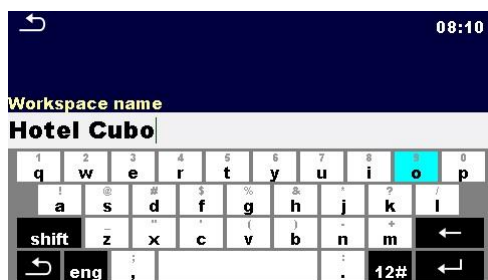

Keypad for entering name of a new Workspace is displayed after selecting New.



After confirmation a new Workspace is added to the list of workspaces.

4.11.2.4 Opening a Workspace



Workspace can be selected from a list in Workspace manager screen.

②



Opens a Workspace in Workspace manager.

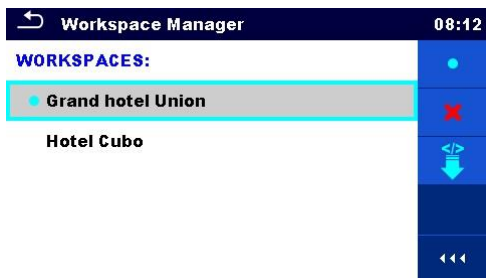

The opened Workspace is marked with a blue dot. The previously opened Workspace will close automatically.

4.11.2.5 Deleting a Workspace / Export

①



Workspace / Export to be deleted should be selected from the list of Workspaces / Exports.

②



Enters option for deleting a Workspace / Export.

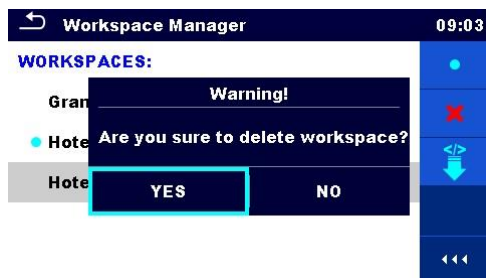



Before deleting the selected Workspace / Export the user is asked for confirmation.

③

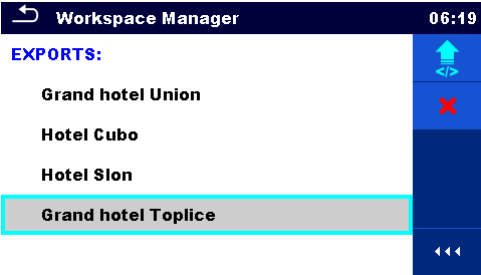
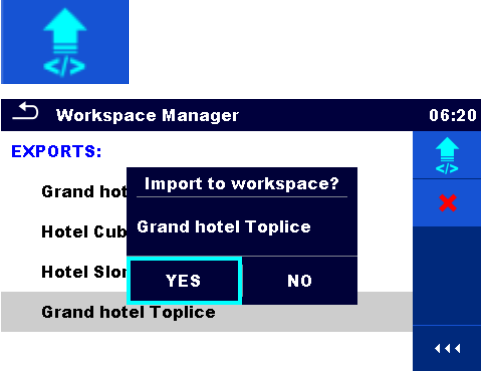

Workspace / Export is deleted from the Workspace / Export list.

4.11.2.6 Importing a Workspace

<p>①</p> 	<p>Select an Export file to be imported from Workspace Manager Export list.</p>
<p>②</p> 	<p>Enters option Import. Before the import of the selected Export file the user is asked for confirmation.</p>
<p>③</p> 	<p>The imported Export file is added to the list of Workspaces. Note: If a Workspace with the same name already exists the name of the imported Workspace will be changed (name_001, name_002, name_003, ...).</p>

4.11.2.7 Exporting a Workspace

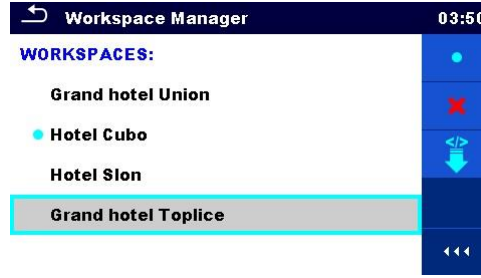
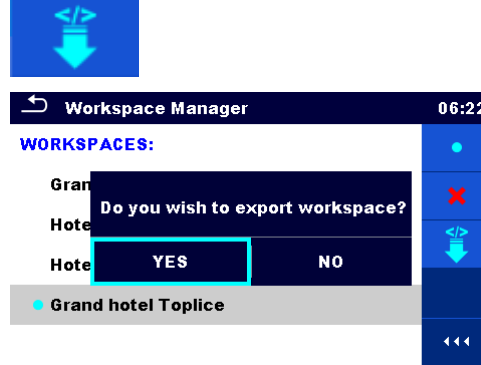
<p>①</p> 	<p>Select a Workspace from Workspace manager list to be exported to an Export file.</p>
<p>②</p> 	<p>Enters option for Export. Before exporting the selected Workspace the user is asked for confirmation.</p>

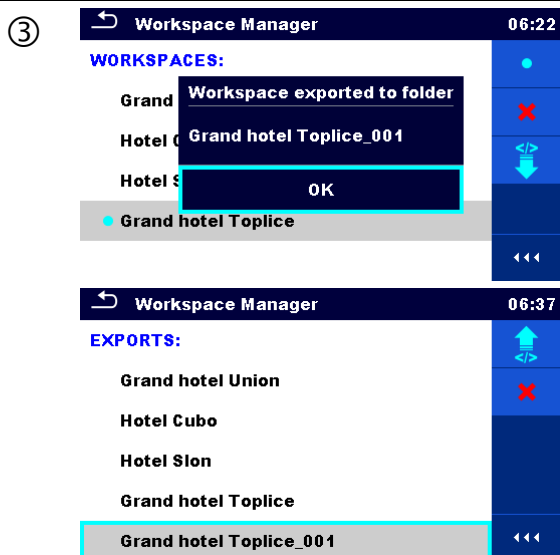

Workspace is exported to Export file and is added to the list of Exports.

Note:

If an Export file with the same name already exists the name of the Export file will be changed (name_001, name_002, name_003, ...).

4.12 Auto Sequence® groups

The Auto Sequences® in the MI 3325 MultiServicerXD can be organized by using lists. In a list a group of similar Auto Sequences® is stored. The Auto Sequence® groups menu is intended to manage with different lists of Auto Sequences® that are stored on the microSD card.

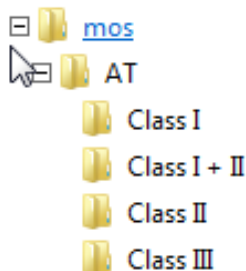

Figure 4.21: Organization of Auto Sequences® on microSD card

Folders with lists of Auto Sequences® are stored in *Root__MOS__\AT* on the microSD card

4.12.1 Auto Sequence® groups menu

Auto Sequence® groups menu can be accessed from General settings menu followed by selection of Auto Sequence® groups menu.

Another option to access it is from Main Auto Sequences® menu, see chapter **7.1 Selection of Auto Sequence®**.

In Auto Sequence® groups menu lists of Auto Sequences® are displayed. Only one list can be opened in the instrument at the same time. The list selected in the Auto Sequence® groups menu will be opened in the Auto Sequences® main menu.

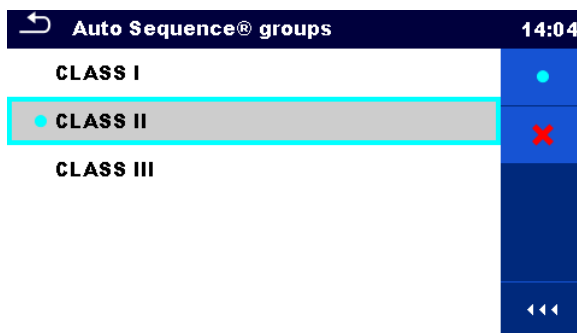

Figure 4.22: Auto Sequence® groups menu

4.12.1.1 Operations in Auto Sequence® groups menu:

Options



Opens the selected group of Auto Sequences®. Previously selected group of Auto Sequences® will be closed automatically. Refer to chapter 4.12.1.2 **Selecting a group of Auto Sequences®** for more information.



Deletes the selected list of Auto Sequences®. Refer to chapter 4.12.1.3 **Deleting a group of Auto Sequences®** for more information.

4.12.1.2 Selecting a group of Auto Sequences®

①

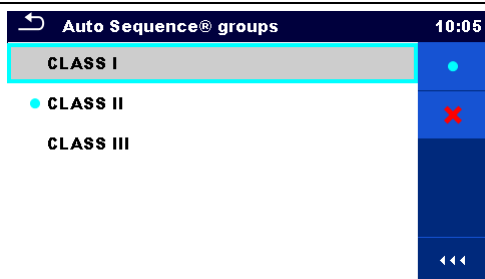

A group of Auto Sequences® should be selected first from the list of Auto Sequence® groups.

②

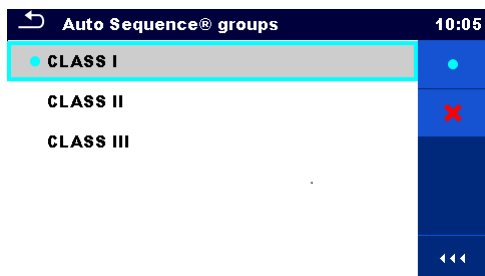

Enters option for selecting a highlighted group.

Selected group of Auto Sequences® is marked with a blue dot.

Note:

Previously selected group is closed automatically.

4.12.1.3 Deleting a group of Auto Sequences®

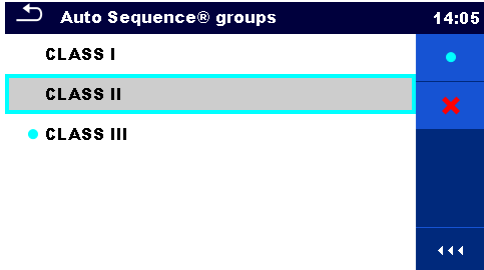
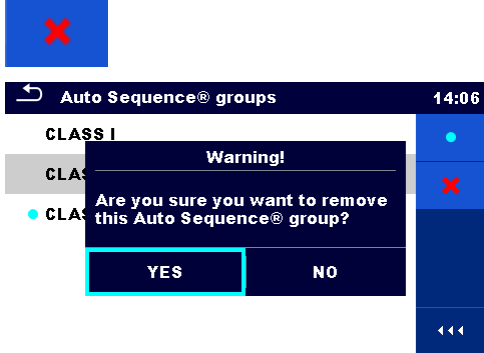
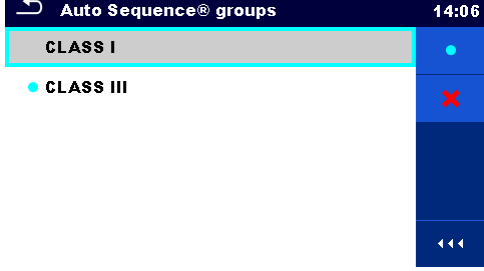
<p>①</p>  <p>The screenshot shows a menu titled 'Auto Sequence® groups' with a timestamp of 14:05. It lists three items: 'CLASS I' with a blue dot, 'CLASS II' with a red 'X' and highlighted in grey, and 'CLASS III' with a blue dot. A blue bar with a red 'X' is visible at the top left of the screenshot.</p>	<p>A group of Auto Sequences® to be deleted should be selected first from the list of Auto Sequence® groups.</p>
<p>②</p>  <p>The screenshot shows the same menu as in step 1, but with a warning dialog box overlaid. The dialog box has a black background and white text: 'Warning!', 'Are you sure you want to remove this Auto Sequence® group?', and two buttons labeled 'YES' and 'NO'. The 'YES' button is highlighted with a blue bar.</p>	<p>Enters option for deleting the selected group.</p> <p>Before deleting the selected group of Auto Sequences®, the user is asked for confirmation.</p>
<p>③</p>  <p>The screenshot shows the 'Auto Sequence® groups' menu with a timestamp of 14:06. 'CLASS I' is now selected and highlighted in grey, with a blue dot next to it. 'CLASS II' is no longer visible, and 'CLASS III' remains with a blue dot. A blue bar with a red 'X' is visible at the top right of the screenshot.</p>	<p>A group of Auto Sequences® is deleted.</p> <p>Note: Selected Auto Sequences® group (marked with blue dot) cannot be deleted, warning message appear on the screen.</p>

5 Memory Organizer

Memory Organizer is a tool for storing and working with test data.

5.1 Memory Organizer menu

The data is organized in a tree structure with Structure objects and Measurements. MultiServicerXD MI 3325 has a multi-level structure. The hierarchy of Structure objects in the tree is shown on **Figure 5.1**. A list of available structure objects can be found in **Appendix A Structure objects in MultiServicerXD**.

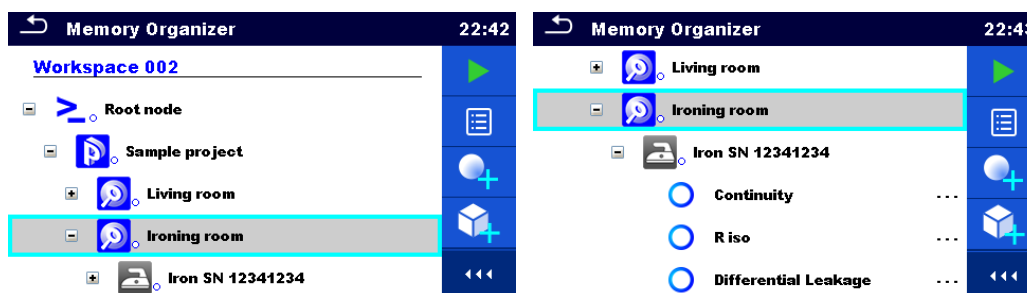

Figure 5.1: Tree structure and its hierarchy

5.1.1 Measurement statuses

Each measurement has:

- › Name,
- › Results,
- › Main result status (Pass or Fail or no status),
- › Limits and parameters.



A measurement can be a Single test or an Auto Sequence[®] test.

Statuses of single tests:

	passed finished single test with test results
	failed finished single test with test results
	finished single test with test results and no status
	empty single test without test results

Overall statuses of Auto Sequence[®]:

or	at least one single test in the Auto Sequence [®] passed and no single test failed.
----	--

	at least one single test in the Auto Sequence® failed.
	at least one single test in the Auto Sequence® was carried out and there were no other passed or failed single tests.
	empty Auto Sequence® with empty single tests.

5.1.2 Structure Objects

Each Structure object has:

- › an icon
- › a name
- › parameters

Optionally they can have:

- › an indication of the status of the measurements under the Structure object
- › a comment or a file attached

Structure objects supported are described in **Appendix A Structure objects in MultiServicerXD.**



Figure 5.2: Structure object in tree menu

5.1.2.1 Measurement status indication under the Structure object

Overall status of measurements under each structure element / sub-element can be seen without spreading tree menu. This feature is useful for quick evaluation of test status and as guidance for measurements.

Options



There are no measurement result(s) under selected structure object. Measurements should be made.



Figure 5.3: Example of status - No measurement result(s)



One or more measurement result(s) under selected structure object has failed. Not all measurements under selected structure object have been made yet.

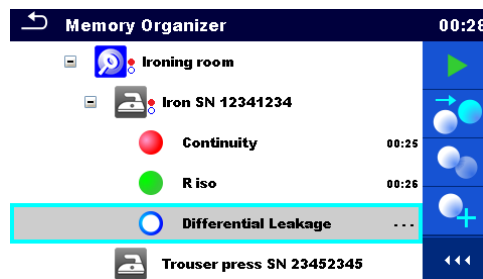

Figure 5.4: Example of status - Measurements not completed with fail result(s)



All measurements under selected structure object are completed but one or more measurement result(s) has failed.



Figure 5.5: Status - Measurements completed with fail result(s)

Note:

- There is no status indication if all measurement results under each structure element / sub-element have passed or if there is an empty structure element / sub-element (without measurements).

5.1.3 Selecting an active Workspace in Memory Organizer

Memory Organizer and Workspace Manager are interconnected so an active Workspace can be selected also in the Memory Organizer menu.

Procedure

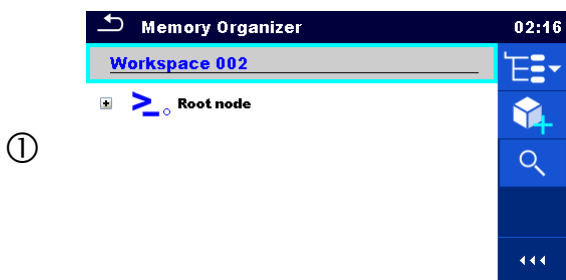

Press the active Workspace in Memory Organizer Menu.

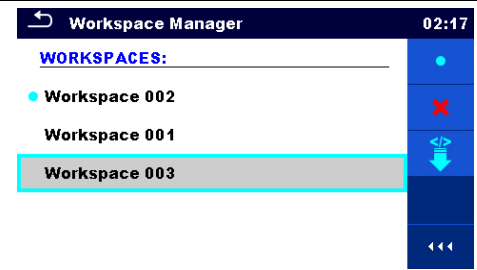

Select List of Workspaces in Control panel.

③  Choose desired Workspace from the list of Workspaces.

③  Use Select button to confirm selection.

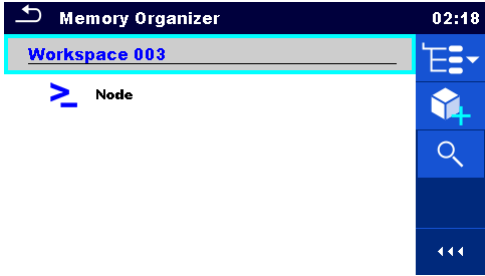
④  New Workspace is selected and displayed on the screen.

5.1.4 Adding Nodes in Memory Organizer

Structural Elements (Nodes) are used to ease organization of data in the Memory Organizer. One Node is a must; others are optional and can be created or deleted freely.

Procedure

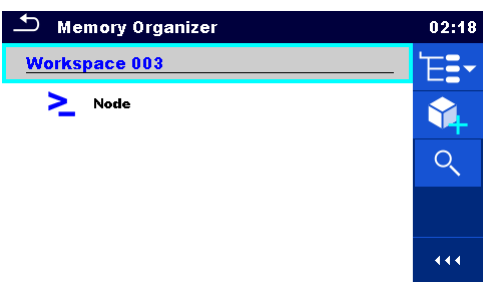
①  Press the active Workspace in Memory Organizer Menu.

②  Select Add New Structure Element in Control panel.

③  Press "Create" to confirm.

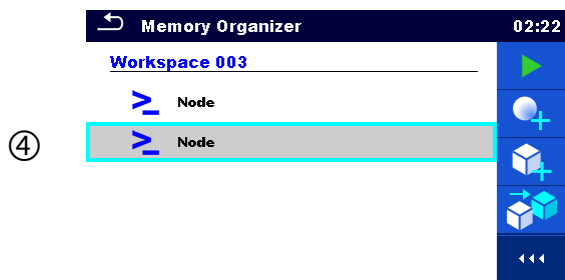

New Structure Element (Node) is added.

Note:
To change the name of a Node, see chapter 5.1.5.15 *Rename a Structure object*.

5.1.5 Operations in Tree Menu

In the Memory organizer different actions can be taken with help of the control panel at the right side of the display. Possible actions depend on the selected element in the organizer.

5.1.5.1 Operations on measurements (finished or empty measurements)

The measurement must be selected first. Operation options can be selected from the menu on the right side of the screen. Menu options are adapted to measurement status, empty, finished, finished and saved, as presented on **Figure 5.6**.

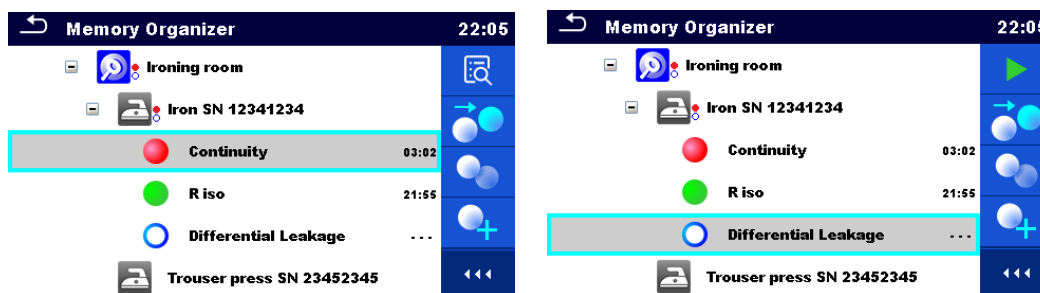

Figure 5.6: A measurement is selected in the tree menu

Options



Views results of measurement.
The instrument goes to the measurement memory screen. Refer to chapter 6.1.1.5 *Single test memory screen* and 7.2.4 *Auto Sequence® memory screen* for more information.



Starts a new measurement.
The instrument goes to the measurement start screen. Refer to chapter 6.1.1.1 *Single test start screen* and 7.2.1 *Auto Sequence® view menu* for more information.





Saves a measurement.
Saving of measurement on a position after the selected (empty or finished) measurement.



Clones the measurement.
The selected measurement can be copied as an empty measurement under the same Structure object. See chapter 5.1.5.8 *Clone a measurement* for more information.

- 

Copies & Paste a measurement.
The selected measurement can be copied and pasted as an empty measurement to any location in structure tree. Multiple “Paste” is allowed. See chapter **5.1.5.11 Copy & Paste a measurement** for more information.
- 

Adds a new measurement.
The instrument goes to the Menu for adding measurements. See chapter **5.1.5.6 Add a new measurement** for more information.
- 

Views and edit comments.
The instrument displays comment attached to the selected measurement or opens keypad for entering a new comment.
- 

Removes a measurement.
Selected Measurement can be deleted. User is asked for confirmation before deleting. See chapter **5.1.5.14 Delete a measurement** for more information.

5.1.5.2 Operations on Structure objects

The structure object must be selected first.

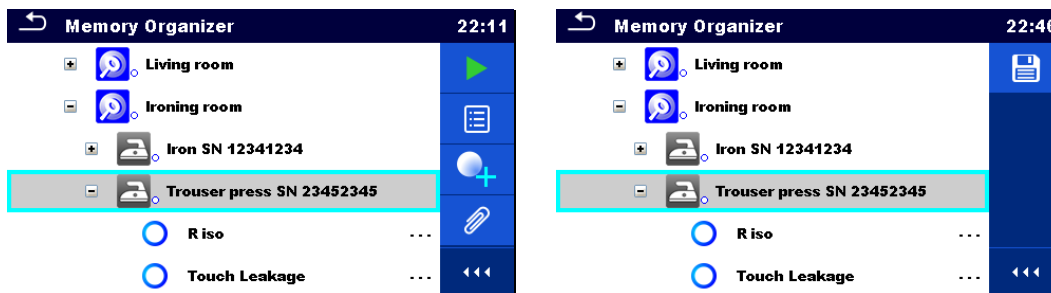





Figure 5.7: A structure object is selected in the tree menu

Options

- 

Starts a new measurement.
First type of measurement (single test or Auto Sequence®) should be selected. After proper type is selected the instrument goes to single test or Auto Sequence® selection screen. Refer to chapters **6.1 Selection of single test** and **7.1 Selection of Auto Sequence®** for more information.
- 

Saves a measurement.
Saving of measurement under the selected Structure object.
- 

View / edit parameters and attachments.
Parameters and attachments of the Structure object can be viewed or edited. Refer to chapter **5.1.5.3 View / Edit parameters and attachments of a Structure object** for more information.
- 

Adds a new measurement.
The instrument goes to the Menu for adding measurement into structure. Refer to chapter **5.1.5.6 Add a new measurement** for more information.

	<p>Adds a new Structure object. A new Structure object can be added. Refer to chapter 5.1.5.5 Add a new Structure Object for more information.</p>
	<p>Attachments. Name and link of attachment is displayed.</p>
	<p>Clones a Structure object. Selected Structure object can be copied to same level in structure tree (clone). Refer to chapter 5.1.5.7 Clone a Structure object for more information.</p>
	<p>Copies & Paste a Structure object. Selected Structure object can be copied and pasted to any allowed location in structure tree. Multiple "Paste" is allowed. Refer to chapter 5.1.5.9 Copy & Paste a Structure object for more information.</p>
	<p>Cut & Paste a Structure. Selected Structure with child items (sub-structures and measurements) can be moved to any allowed location in structure tree. Refer to chapter 5.1.5.12 Cut & Paste a Structure object with sub-items for more information.</p>
	<p>Views and edit comments. The instrument displays comment attached to the selected Structure object or opens keypad for entering a new comment.</p>
	<p>Removes a Structure object. Selected Structure object and sub-elements can be deleted. User is asked for confirmation before the deleting. Refer to chapter 5.1.5.13 Delete a Structure object for more information.</p>
	<p>Renames a Structure object. Selected Structure object can be renamed via keypad. Refer to 5.1.5.15 Rename a Structure object for more information.</p>

5.1.5.3 View / Edit parameters and attachments of a Structure object

The parameters and their content are displayed in this menu. To edit the selected parameter tap on it or press **ENTER** key to enter menu for editing parameters.



Parameters

↶ Memory Organizer / Parameters 00:22

🖨️ IT Equipment

Appliance ID	IT Equipment
Inventory No.	PC 12344321
Name	PC / Monitor
Location (Room)	Living room

Figure 5.8: Example of View / Edit parameters menu

Procedure and options

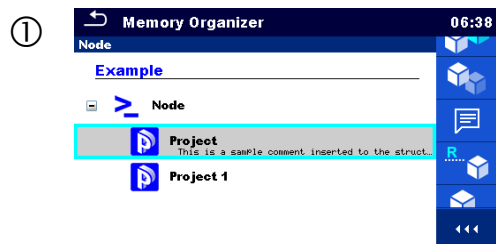

Select structure object to be edited.



Select Parameters in Control panel.

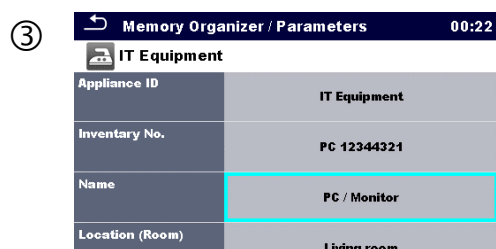

Example of Parameters menu.

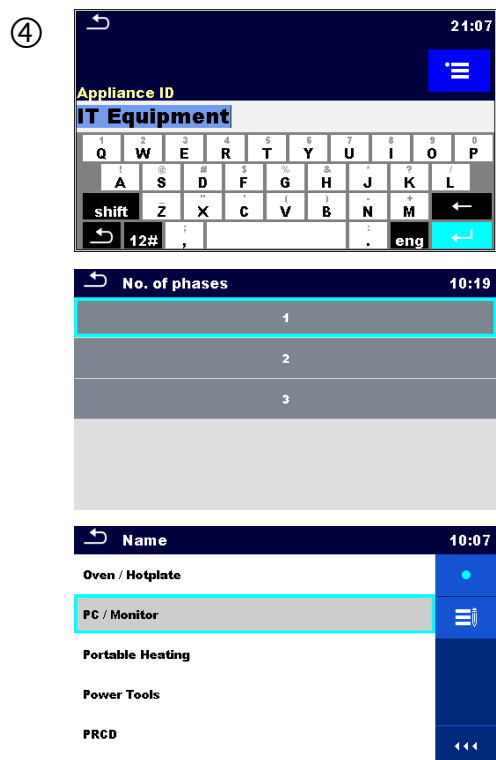

In menu for editing parameters the parameter's value can be selected from a drop-down list or entered via keypad. Refer to chapter 4 **Instrument operation** for more information about keypad operation.

Note:

Some structure parameters include custom lists. See chapter 5.1.5.4 **Custom lists of Structure parameter values** for details.



Select Attachments in Control panel.

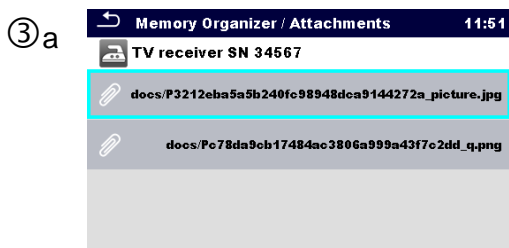

Attachments

The name of attachment can be seen. Operation with attachments is not supported in the instrument.



Select Comments in Control panel.



View or edit comments

Complete comment (if exists) attached to the structure object can be seen on this screen.

Press **ENTER** key or tap on screen to open keypad for entering a new comment.

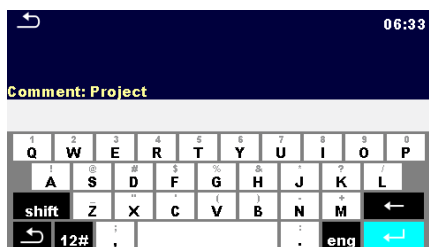

5.1.5.4 Custom lists of Structure parameter values

Some structure parameters include option to create custom lists of values for particular structure parameter. These custom values can be re-used easily, by selecting it from the custom lists, and re-typing is therefore not required.



Custom list



Figure 5.9: Example of Virtual keyboard with Custom list option

Procedure and options

- ①

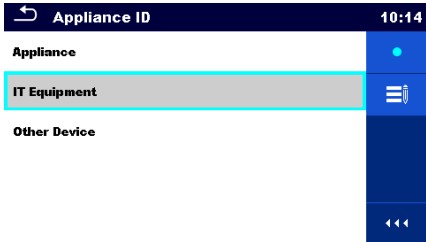

Custom list view.
- ②

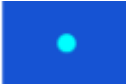

Select focused value from Custom list.
- ③a



Edit Custom list.
- ③b

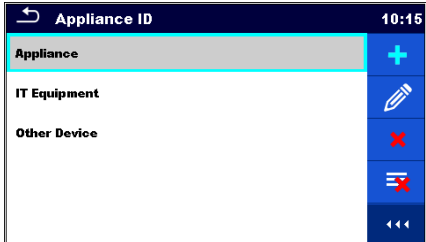

Custom list Edit options.
- ④a



Add new value to the Custom list.
- ④b



Edit selected Custom list value.
- ④c



Delete selected Custom list value.
- ④d



Delete Custom list (all values).

5.1.5.5 Add a new Structure Object

This menu is intended to add new structure objects in the tree menu. A new structure object can be selected and then added in the tree menu.

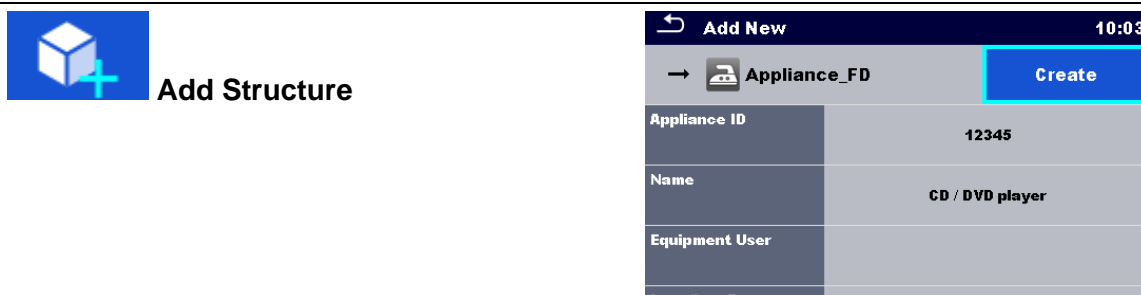
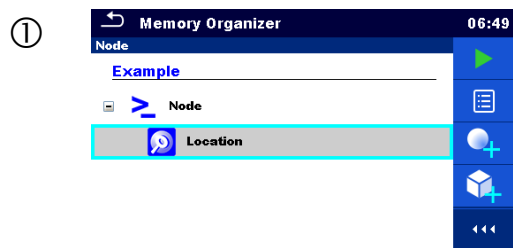

Figure 5.10: Add a new Structure Object menu

Procedure and options



Default initial structure.



Select Add Structure in Control panel.

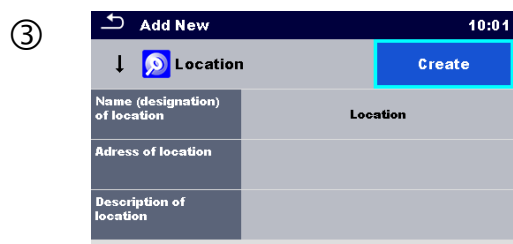

Add a new structure object menu.



Tap on a structure type selection window.

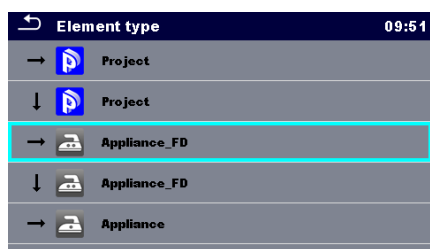

A list of available structure items is displayed. Select one from a list. Arrow indicates the position where structure item will be inserted.



Child item to the currently selected structure item.



Structure item located in the same level.

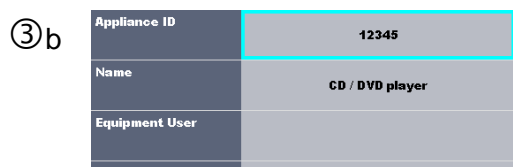

In menu for editing name and parameters the parameter's value can be selected from a dropdown list or entered via keypad. Refer to chapter 4 **Instrument operation** for more information about keypad operation.

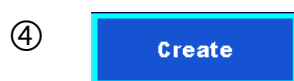

Create new structure item.

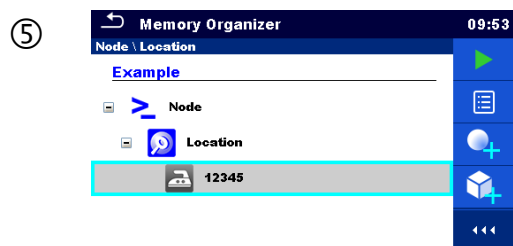

New object added.

5.1.5.6 Add a new measurement

In this menu new empty measurements can be set and then added in the structure tree. The type of measurement, measurement function and its parameters are first selected and then added under the selected Structure object.

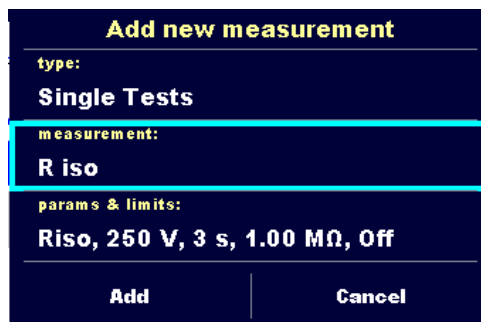
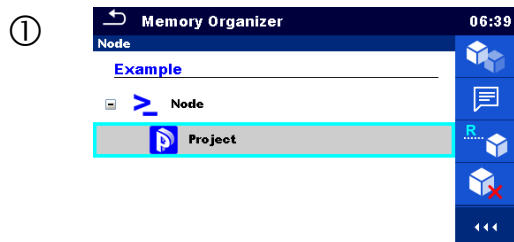

Figure 5.11: Add a new measurement menu

Procedure and options



Select level in structure where measurement will be added.



Select Add measurement in Control panel.

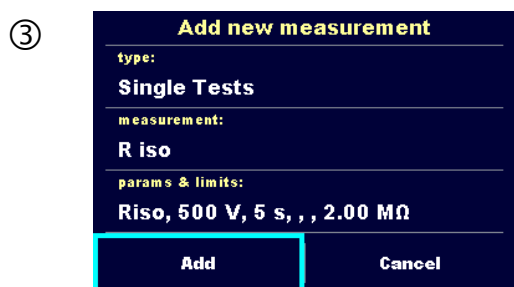

Add new measurement menu.



Type of test can be selected from this field.
Options: (Single Tests, Auto Sequences®)
Tap on field or press the **ENTER** key to modify.

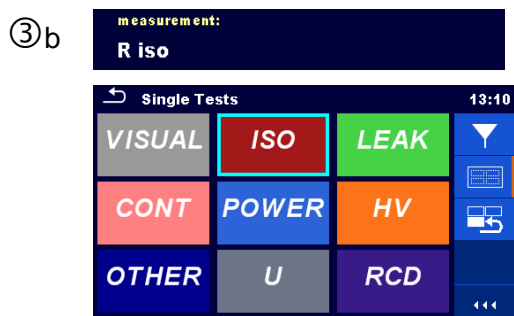

Last added measurement is offered by default.
To select another measurement tap on field or press the **ENTER** key to open menu for selecting measurements. Refer to chapters **6.1 Selection of single test** and **7.1 Selection of Auto Sequence®** for more information.

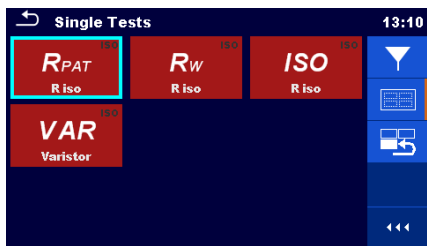

③ c



Select parameter and modify it as described earlier.

Refer to chapter **6.1.1.2 Setting parameters, limits and comments** of single tests for more information.

④

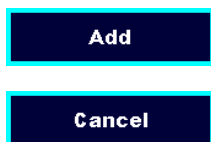

Adds the measurement under the selected Structure object in the tree menu.

Returns to the structure tree menu without changes.

⑤

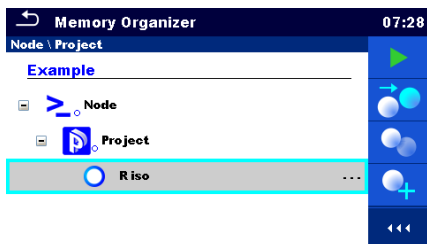

New empty measurement is added under the selected Structure object.

5.1.5.7 Clone a Structure object

In this menu selected structure object can be copied (cloned) to same level in the structure tree. Cloned structure object has same name as original.



Clone

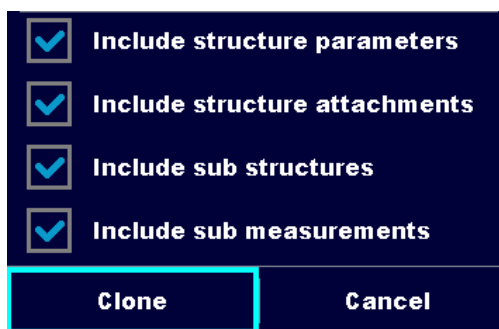
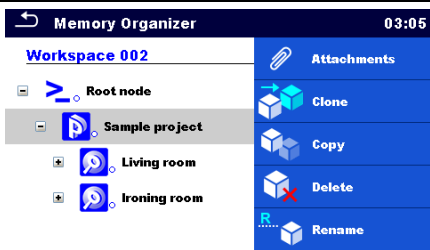

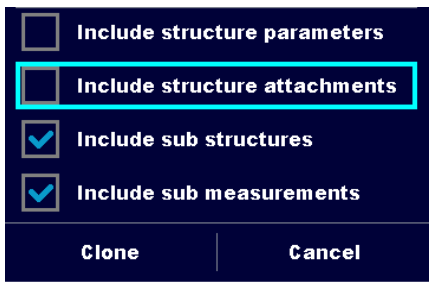



Figure 5.12: Clone Structure Object menu

Procedure and options

①  Select the structure object to be cloned.

②  Select Clone option from control panel.

③  The Clone Structure object menu is displayed. Sub-elements of the selected structure object can be marked or un-marked for cloning. Refer to chapter **5.1.5.10 Cloning and Pasting sub-elements of selected structure object** for more information.

④a  Selected structure object is copied (cloned) to same level in the structure tree.

④b  Cloning is cancelled. No changes in the Structure tree.

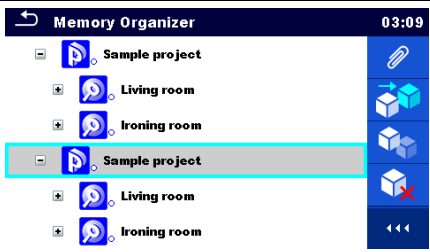
⑤  The new structure object is displayed.

5.1.5.8 Clone a measurement

By using this function, a selected empty or finished measurement can be copied (cloned) as an empty measurement to the same level in the structure tree.

Procedure and options

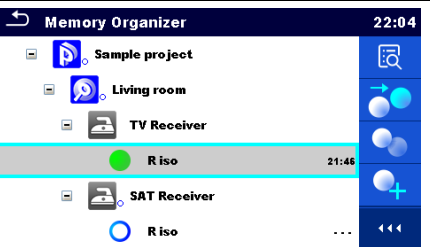
①  Select the measurement to be cloned.

②  Select Clone option from control panel.

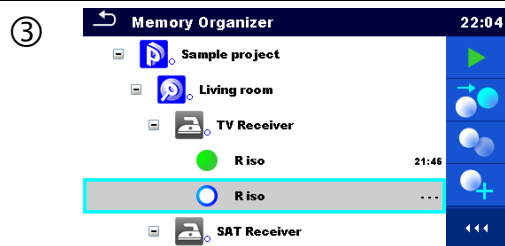

The new empty measurement is displayed.

5.1.5.9 Copy & Paste a Structure object

Structure object can be copied and pasted to any allowed location in the structure tree.

Procedure and options

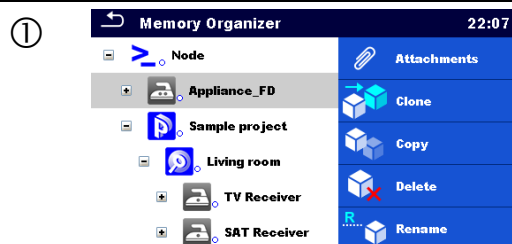

Select the structure object to be copied.



Select Copy option from control panel.

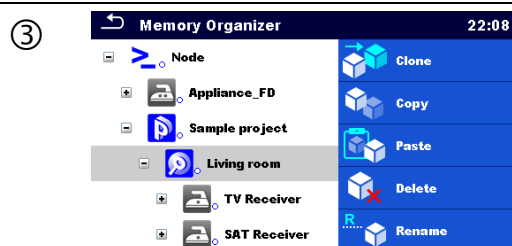

Select location where structure element should be copied.



Select Paste option from control panel.

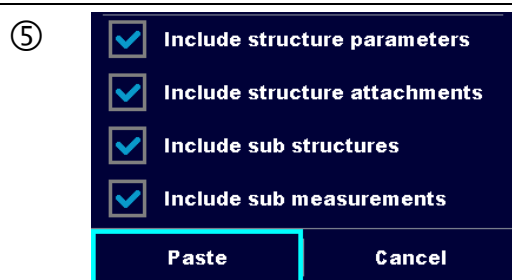

The Paste structure object menu is displayed. Before copying it can be set which sub-elements of the selected structure object will be copied too. For more details see chapter **5.1.5.10 Cloning and Pasting sub-elements of selected structure object**.

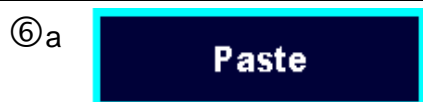

The selected structure object and elements are copied (pasted) to selected position in the tree structure.



Returns to the tree menu without changes.

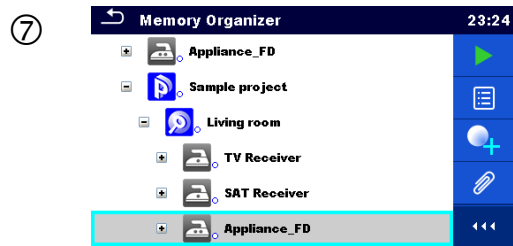

The new structure object is displayed.

Note:

The Paste command can be executed one or more times.

5.1.5.10 Cloning and Pasting sub-elements of selected structure object

When structure object is selected to be cloned, or copied & pasted, additional selection of its sub-elements is needed. The following options are available:

Options



Parameters of selected structure object will be copied too.



Attachments of selected structure object will be copied too.



Structure objects in sub-levels of selected structure object will be copied too.



Measurements in selected structure object and sub-levels will be copied too.

5.1.5.11 Copy & Paste a measurement

In this menu selected measurement can be copied to any allowed location in the structure tree.

Procedure



Select the measurement to be copied.



Select Copy option from control panel.



Select location where measurement should be copied.



Select Paste option from control panel.



A new (empty) measurement is displayed in selected Structure object.

5.1.5.12 Cut & Paste a Structure object with sub-items

In this menu selected Structure object with sub-items (sub-structures and measurements) can be cut and pasted (moved) to any allowed location in the structure tree.

Procedure

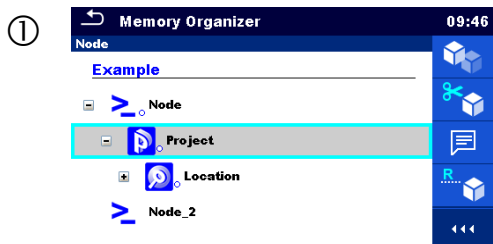

Select the structure item to be moved.



Select Cut option from Control panel.

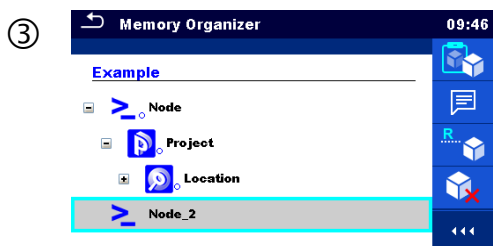

Select new location where structure object (with sub-structures and measurements) should be moved.



Select Paste option from Control panel.

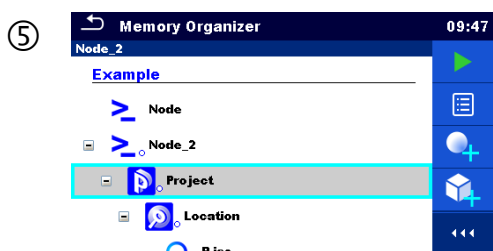





The structure object (with sub-structures and measurements) is moved to selected new location and deleted from previous location in the tree structure.

5.1.5.13 Delete a Structure object

In this menu selected Structure object can be deleted.

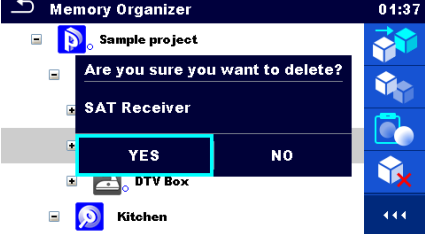
Procedure

<p>①</p> 	<p>Select the structure object to be deleted.</p>
<p>②</p>  <p>Delete</p>	<p>Select Delete option from control panel.</p>
<p>③</p> 	<p>A confirmation window will appear.</p>
<p>④a</p> 	<p>Selected structure object and its sub-elements are deleted.</p>
<p>④b</p> 	<p>Returns to the tree menu without changes.</p>

5.1.5.14 Delete a measurement

In this menu selected measurement can be deleted.

Procedure

①  Select a measurement to be deleted.

②  Select Delete option from control panel.

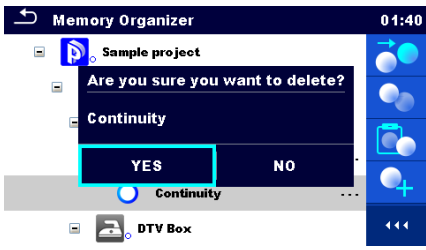
③  A confirmation window will appear.

④a  Selected measurement is deleted.

④b  Returns to the tree menu without changes.

5.1.5.15 Rename a Structure object

In this menu selected Structure object can be renamed.

Procedure

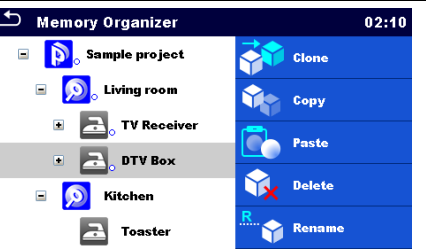





①  Select the structure object to be renamed.

②  Select Rename option from control panel.

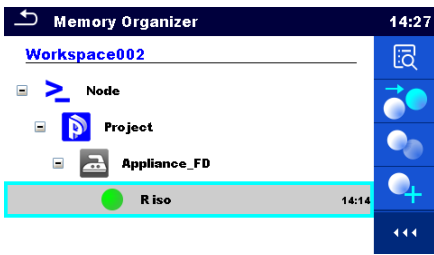
③  Virtual keypad will appear on screen. Enter new text and confirm.

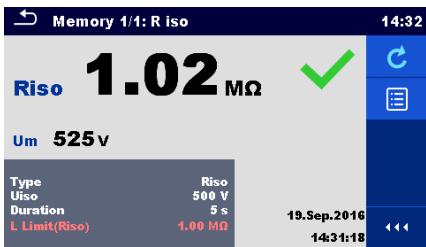
5.1.5.16 Recall and Retest selected measurement

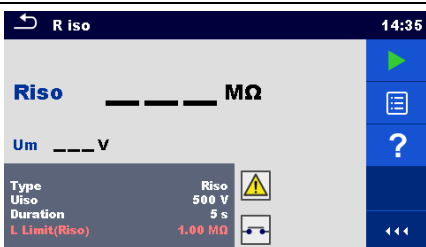
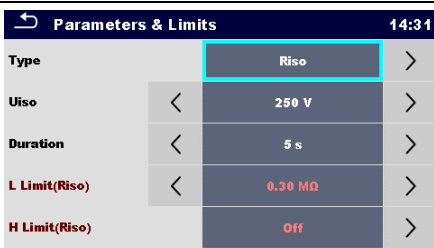
Procedure

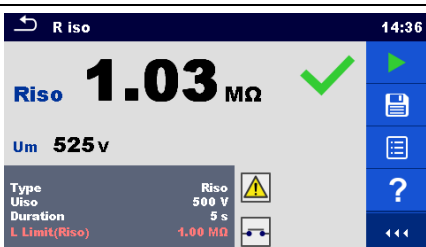
①		Select the measurement to be recalled.
②	 <p>View</p>	Select Recall results in Control panel.
③		Measurement is recalled. Parameters and limits can be viewed but cannot be edited.
④	 <p>Retest</p>	Select Retest in Control panel.
⑤		Measurement retest starting screen is displayed.
⑤a		Parameters and limits can be viewed and edited.
⑥		Select Run in Control panel to retest the measurement.
⑦		Results / sub-results after re-run of recalled measurement.

⑧



Select Save results in Control panel.

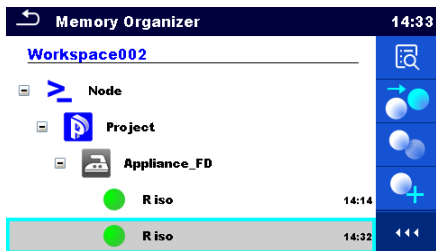

Retested measurement is saved under same structure object as original one.

Refreshed memory structure with the new performed measurement is displayed.

5.1.6 Searching in Memory Organizer

In Memory organizer, it is possible to search for different structure objects and parameters. Instrument support data entry with application of Bar code, QR code, NTAG/NFC reader, to search for specific tagged structure element within active workspace. See chapter **4.9 Devices** for details on setting of external devices.

Procedure

①



Search function is available from the active workspace directory line.

Use external device for data entry or follow instructions below for instrument search function.

②



Select Search in control panel to open Search setup menu.

③

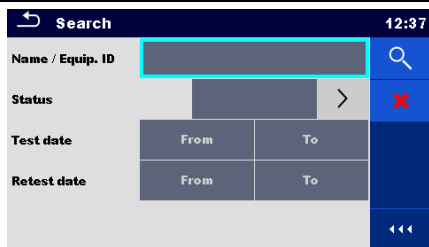

The parameters that can be searched for are displayed in the Search setup menu.

Note:

- Equipment ID, Test date and Retest date (if applicable) refer only to the following structure objects: Appliance, Appliance FD, Welding equipment, Welding equipment FD, Machine, Switchgear.

③ a

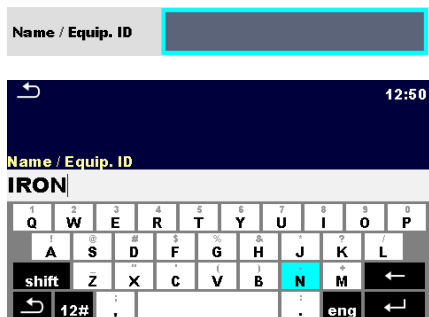

The search can be narrowed by entering a text in the Name and Equipment ID fields.

Strings can be entered using the on-screen keyboard.

③ b



The search can be narrowed on base of statuses.

If searching by status, instrument will display all structure objects that include one or more

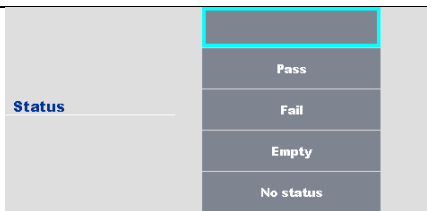

measurements with searched status.

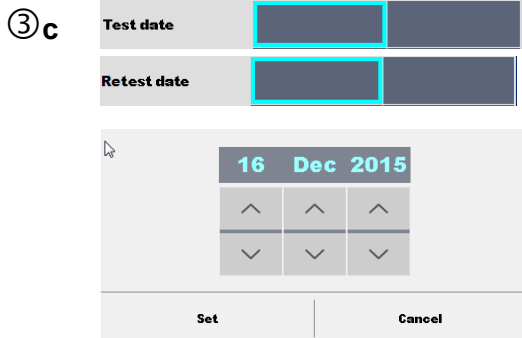

The search can be narrowed on base of test dates / retest dates (from / to).



Clear filters

Clears all filters. Sets filters to default value.



Search

Searches through the Memory Organizer for objects according to the set filters. The results are shown in the Search results screen presented on **Figure 5.13** and **Figure 5.14**.

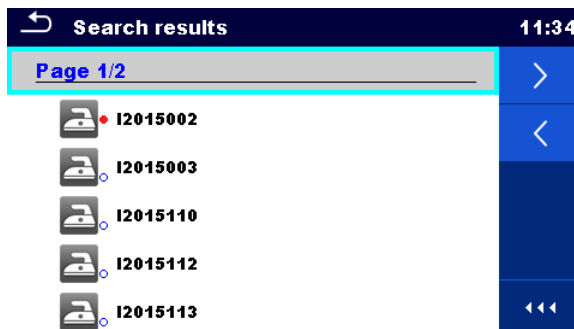

Figure 5.13: Search results screen – Page view

Options



Next page.



Previous page.

Note:

- › Search result page consist of up to 50 results.

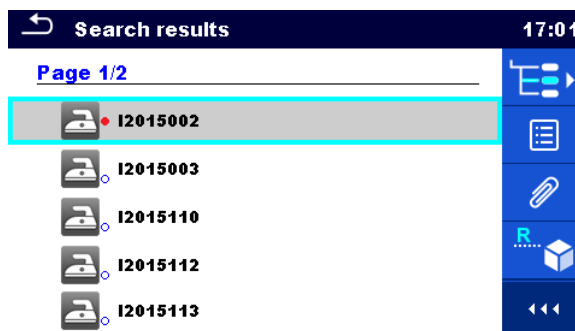

Figure 5.14: Search results screen with structure object selected

Options



Goes to selected location in Memory Organizer.



View / edit parameters and attachments. Parameters and attachments of the Structure object can be viewed or edited. Refer to Chapter **5.1.5.3 View / Edit parameters and attachments of a Structure object** for more information.



Attachments. Name and link of attachment is displayed.



Views comment. The instrument displays comment attached to the selected Structure object.



Renames the selected Structure object. Refer to Chapter **5.1.5.15 Rename a Structure object** for more information.

6 Single tests

6.1 Selection of single test

Single tests can be selected in the Main Single Tests menu or in Memory Organizer’s main and submenus. It is possible to select the area group and two different modes for selecting single tests.

Options

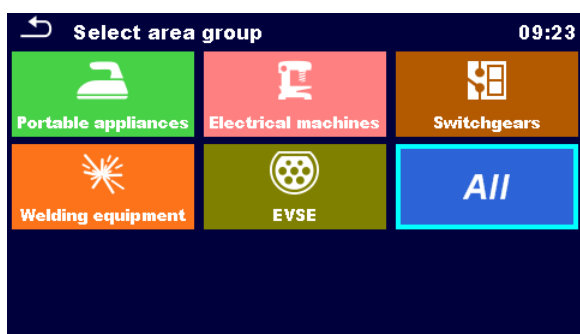

Area Group

With help of area groups, it is possible to limit the offered single tests. The instrument has five area groups:

- the Portable appliances group
- the Electrical machines group
- the Switchgears group
- the Welding equipment group
- the EVSE group

In the All group all measurements are offered.

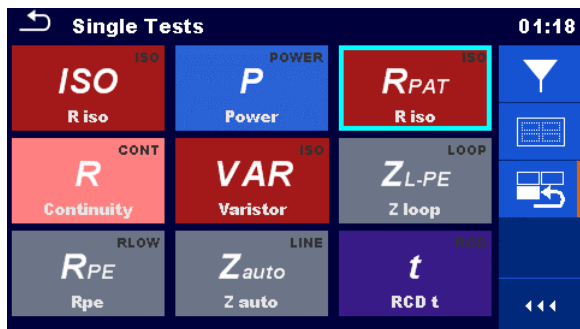

Last used

Up to the last 9 different executed single tests are displayed.



Groups

The single tests are divided into groups of similar tests.

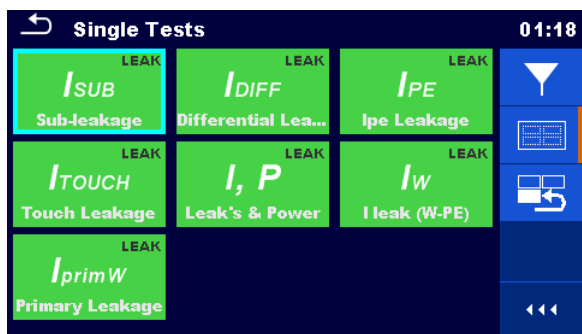
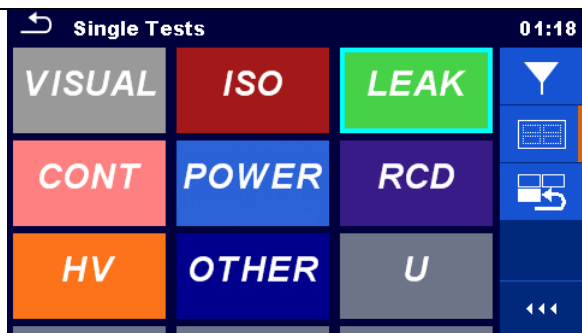

For the selected group a submenu with all single tests that belongs to the selected group is displayed.

6.1.1 Single test screens

In the Single test screens measuring results, sub-results, limits and parameters of the measurement are displayed. In addition, on-line statuses, warnings and other information are displayed.

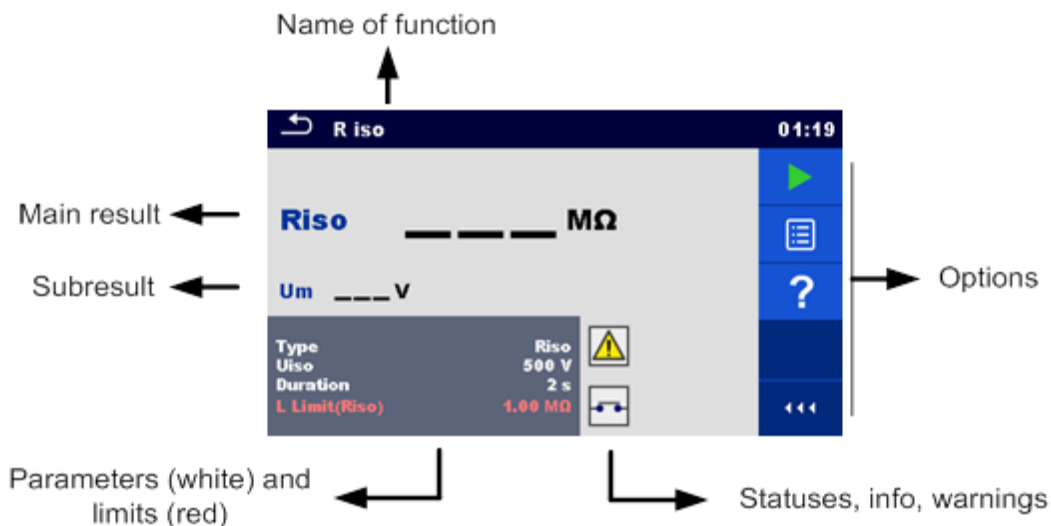

Figure 6.1: Single test screen organisation

6.1.1.1 Single test start screen

Single test screen can be opened from Memory organizer or from Single test main menu.

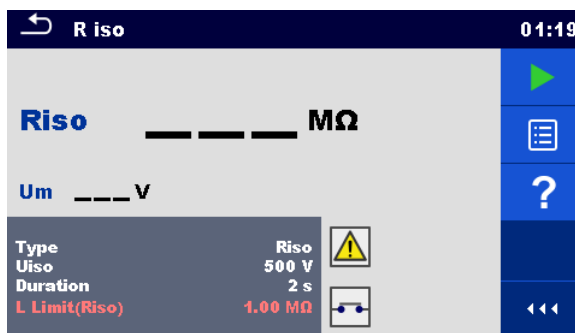

Figure 6.2: Single test start screen

Options



Starts the measurement.



Opens help screens. Refer to chapter **6.1.3 Help screens** or more information.



or



on

Type	Riso
Uiso	500 V
Duration	2 s
L Limit(Riso)	1.00 MΩ

Opens menu for changing parameters and limits. Refer to chapter **6.1.1.2 Setting parameters, limits and comments of single tests** for more information.

6.1.1.2 Setting parameters, limits and comments of single tests

Procedure

①

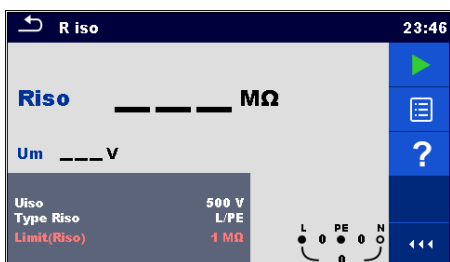

Select the test or measurement.

The test can be entered from:

- Single tests menu or
- Memory organizer menu once the empty measurement was created in selected object structure.

②



Select Parameters in Control panel.



on

Uiso	500 V
Type Riso	L/N
Limit(Riso)	2 MΩ

Opens parameters and limits setting menu.

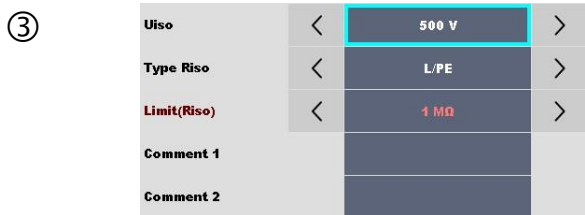

Parameters and Limits menu.
Some single tests support user comment entry.
Parameters and comments are white and limits are red.

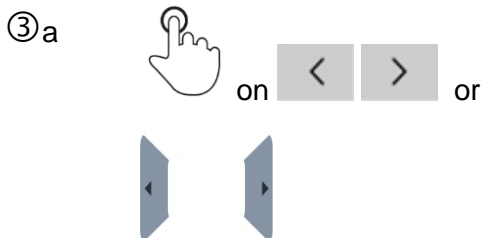

Modify parameter or limit value with touchscreen or keyboard buttons.

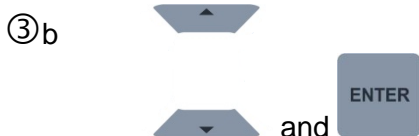

Select parameter to be edited or limit / comment to be set.

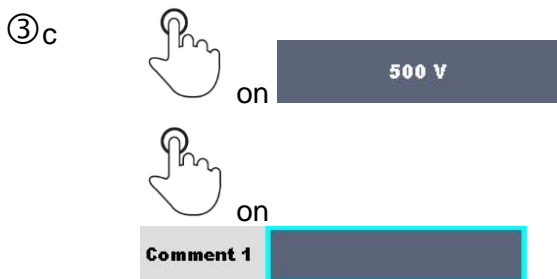

Opens parameter or limit selection list or on-screen keyboard for entering comment.



In case of many (multiple pages of) parameters or limits:

- The scroll bar on the right side of screen can be used
- With right / left keys it can be jumped page up / page down

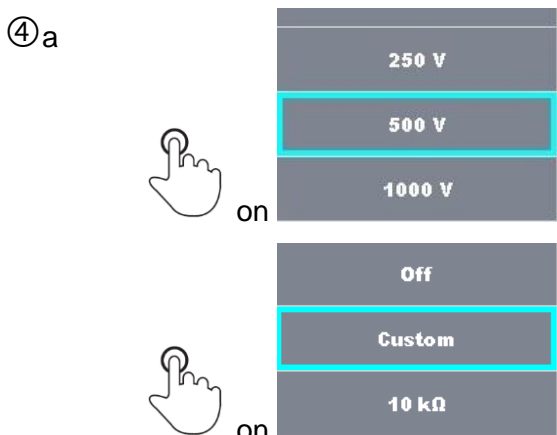

Select parameter or limit value from the list or select custom value (if applicable).

Note:
Touchscreen or keyboard selection methods can be used interchangeably; confirm keyboard selection with .



Numeric keyboard with metric prefixes will open.



Enters custom limit value and confirm .

⑤



on

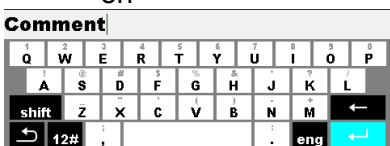

Enter comment and confirm with .

⑥



Accepts and set selected parameters, selected limit values and user comments and exits Single Test setting.

Note:

- Set parameters, set limits and entered user comments are saved to the memory. When same Single test is used next time, settings and comments will remain the same.

6.1.1.3 Single test screen during test

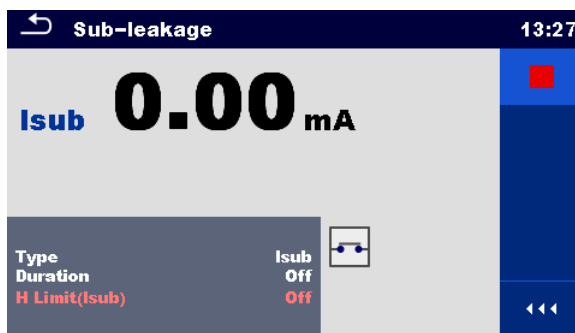

Figure 6.3: Single test screen (during measurement)

Options (during test)



Stops the single test measurement.



Proceeds to the next step of the measurement (if measurement consists of more steps).



Aborts measurement.

6.1.1.4 Single test result screen

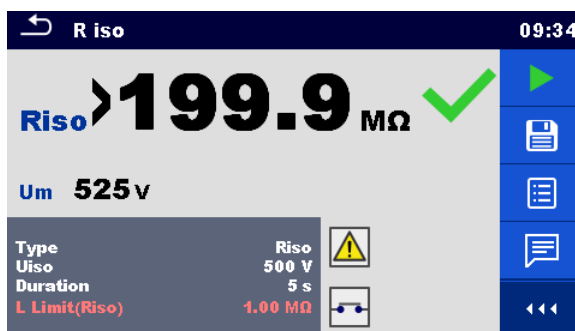

Figure 6.4: Single test result screen

Options (after measurement is finished)



Starts a new measurement.



Saves the result.

A new measurement was selected and started from a Structure object in the structure tree:

- The measurement will be saved under the selected Structure object.

A new measurement was started from the Single test main menu:

- Saving under the last selected Structure object will be offered by default. The user can select another Structure object or create a new Structure object. By pressing the  key in Memory organizer menu the measurement is saved under selected location.

An empty measurement was selected from structure tree and started:

- The result(s) will be added to the measurement. The measurement will change its status from 'empty' to 'finished'.

An already carried out measurement was selected from structure tree, viewed and then restarted:

- A new measurement will be saved under the selected Structure object.



Adds comment to the measurement. The instrument opens keypad for entering a comment.



Opens help screens. Refer to chapter **6.1.3 Help screens** for more information.



or

Opens screen for changing parameters and limits. Refer to chapter **6.1.1.2 Setting parameters, limits and**

 on

Type	Riso
Uiso	500 V
Duration	2 s
L Limit(Riso)	1.00 MΩ

comments of single tests for more information.

6.1.1.5 Single test memory screen

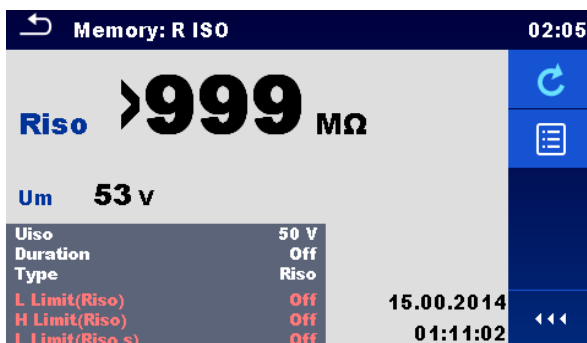



Figure 6.5: Single test memory screen

Options



or

 on

Type	Riso
Uiso	500 V
Duration	2 s
L Limit(Riso)	1.00 MΩ

Opens menu for viewing parameters and limits. Refer to chapter **6.1.1.2 Setting parameters, limits and comments of** single tests for more information.



Retest

Enters screen with “empty” measurement.

6.1.2 Single test (inspection) screens

Visual and Functional inspections can be treated as a special class of tests. Items to be visually or functionally checked are displayed. In addition, on-line statuses and other information are displayed.

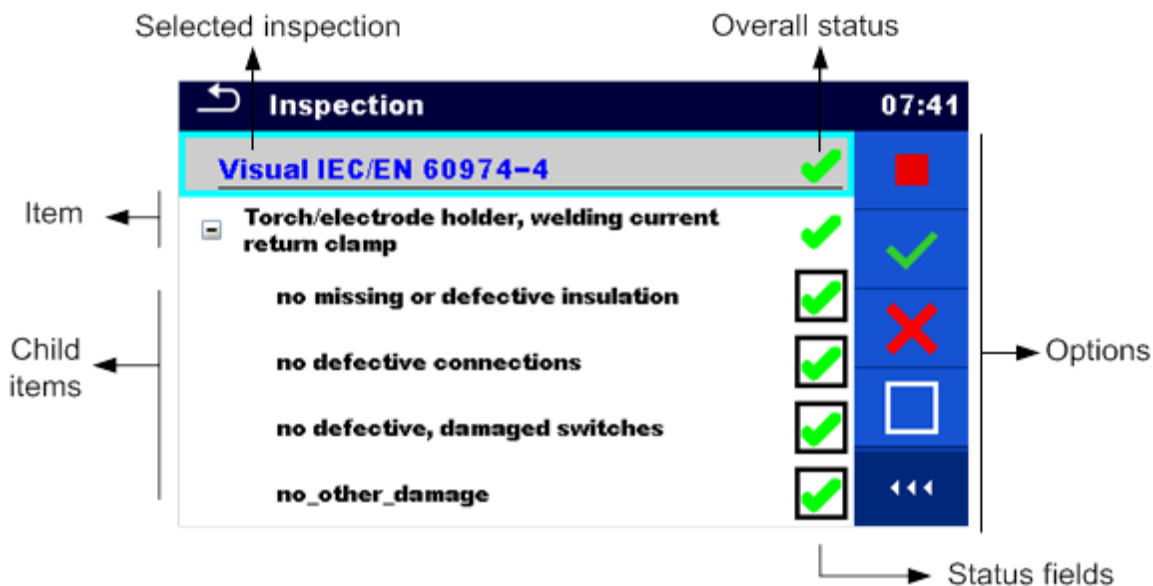

Figure 6.6: Inspection screen organisation

6.1.2.1 Single test (inspection) start screen

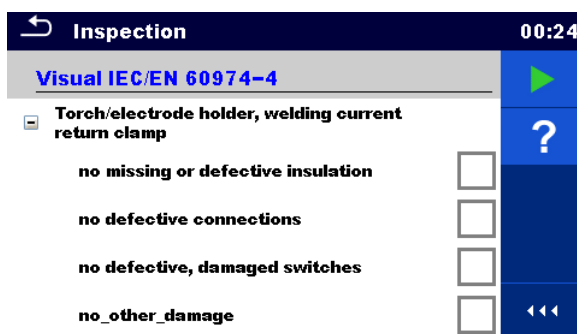

Figure 6.7: Inspection start screen

Options (inspection screen was opened in Memory organizer or from Single test main menu)



Starts the inspection.



Opens help screens. Refer to chapter **6.1.3 Help screens** for more information.

6.1.2.2 Single test (Inspection) screen during test

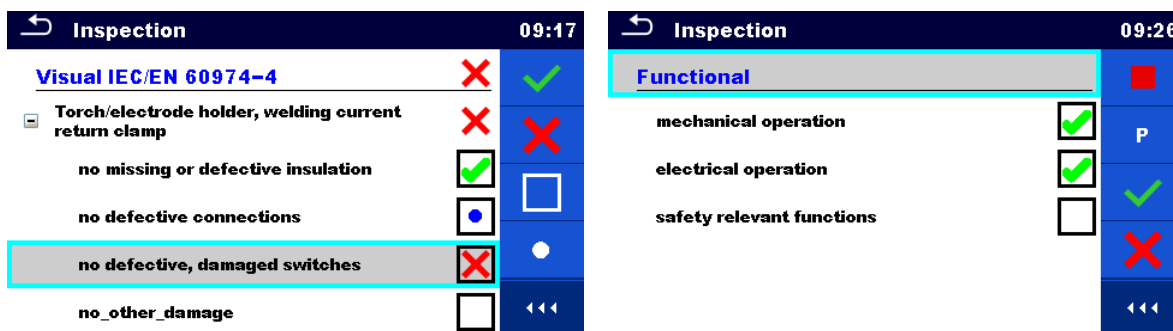

Figure 6.8: Inspection screen (during inspection)

Options (during test)

	Selects item.
	Applies a pass status to the selected item or group of items.
	Applies a fail status to the selected item or group of items.
	Clears status in selected item or group of items.
	Applies a checked status to the selected item or group of items.
	A status can be applied direct to the checkbox; successive tap toggle between statuses.
	Toggle between statuses.
	Power is applied to the mains test socket to power up the tested equipment during a functional inspection. The instrument displays the Power measurement screen, refer to chapter 6.2.14 Power for details.
	Stops Power measurement. Stops the inspection.
	Stops the inspection. Goes to the result screen.

Rules for automatic applying of statuses:

- › The parent item(s) can automatically get a status on base of statuses in child items.
 - the fail status has highest priority. A fail status for any item will result in a fail status in all parent items and an overall fail result.
 - if there is no fail status in child items the parent item will get a status only if all child items have a status.
 - Pass status has priority over checked status.
- › The child item(s) will automatically get a status on base of status in the parent item
 - All child items will get the same status as applied to the parent item.

Notes

- › Inspections and even inspection items inside one inspection can have different status types. For example, some basic inspections don't have the 'checked' status.
- › Only inspections with overall statuses can be saved.

6.1.2.3 Single test (Inspection) result screen

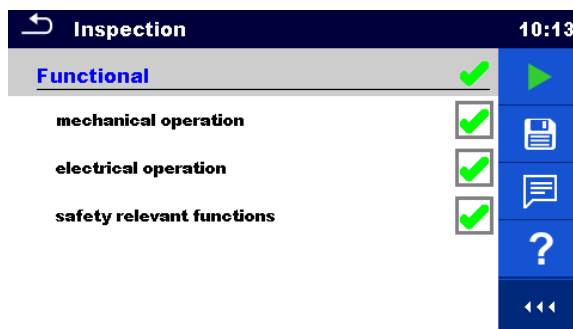

Figure 6.9: Inspection result screen

Options (after inspection is finished)



Starts a new inspection.



Saves the result.

A new inspection was selected and started from a Structure object in the structure tree:

- The inspection will be saved under the selected Structure object.

A new inspection was started from the Single test main menu:

- Saving under the last selected Structure object will be offered by default. The user can select another Structure object or create a

new Structure object. By pressing the  key in Memory organizer menu the inspection is saved under selected location.

An empty inspection was selected in structure tree and started:

- The result(s) will be added to the inspection. The inspection will change its status from 'empty' to 'finished'.

An already carried out inspection was selected in structure tree, viewed and then restarted:

- A new measurement will be saved under the selected Structure object.



Adds comment to the measurement. The instrument opens keypad for entering a comment.



Opens Help screen, see chapter **6.1.3 Help screens** for more information.

6.1.2.4 Single test (inspection) memory screen

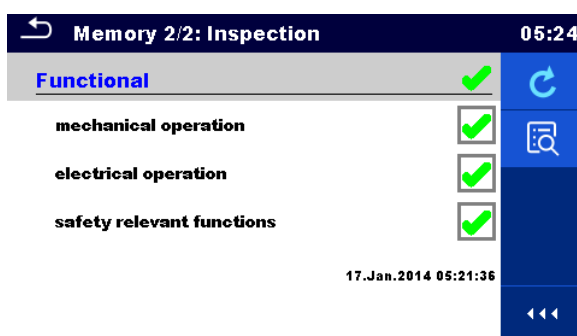

Figure 6.10: Inspection memory screen

Options



Retest

Starts inspection with cleared statuses.



Enters view mode.

6.1.3 Help screens

Help screens contain diagrams for proper connection of the instrument.

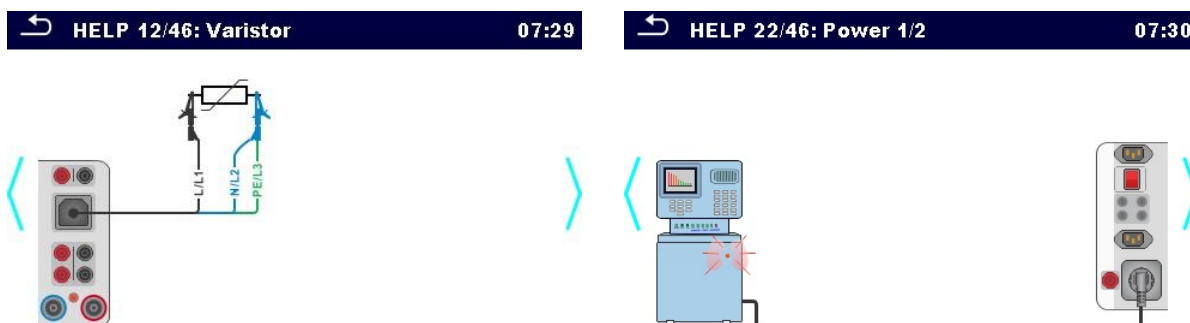
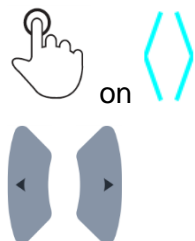

Figure 6.11: Examples of help screens

Options



Opens help screen.



Goes to previous / next help screen.



Back to test / measurement menu.

6.2 Single test measurements

6.2.1 Visual inspection

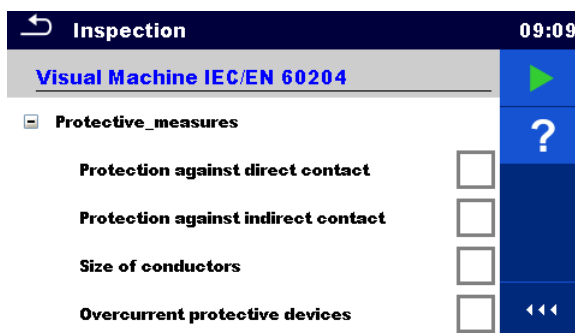

Figure 6.12: Visual inspection menu

Test circuit

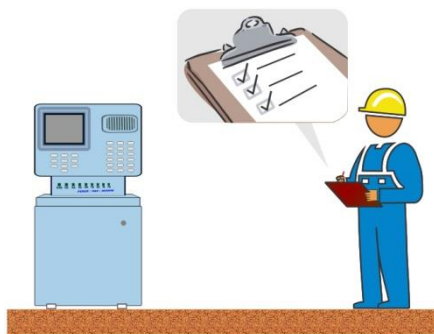

Figure 6.13: Visual inspection test circuit

Visual inspection procedure

- › Select the appropriate **Visual** function.

- › Start the inspection.
- › Perform the visual inspection of the appliance / equipment.
- › Apply appropriate ticker(s) to items of inspection.
- › End inspection.
- › Save results (optional).

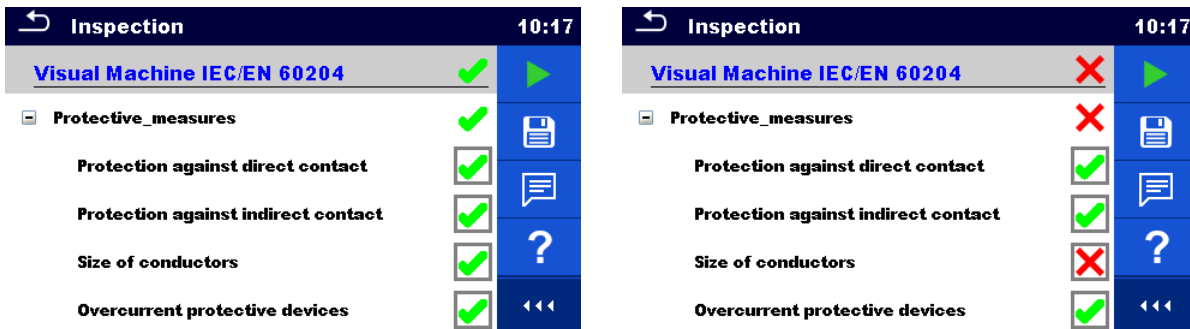

Figure 6.14: Examples of Visual inspection results

6.2.2 Continuity

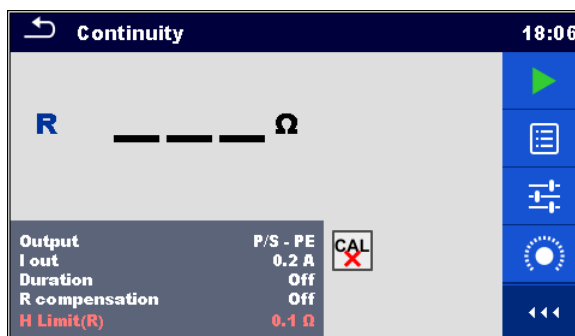

Figure 6.15: Continuity test menu

Test results / sub-results

R..... Resistance
 ΔU Voltage drop scaled to 10 A

Test parameters

Output	Output connections [4-wire, P/S - PE, MS_PE - IEC_PE]
I out	Test current [0.2 A, 4 A, 10 A, 25 A]
Duration	Duration [Off, 2 s ... 180 s]
R compensation	Manual resistance compensation [Off, Custom]
ΔU test	Enables ΔU test* [On, Off]
Wire cross-section	Wire cross-section for ΔU test ** [0.5 mm ² ... \geq 6mm ²]



Test limits

H limit(R)	High limit (R) [Off, Custom, 0.01 Ω ... 9 Ω]
Limit (ΔU)	Limit (ΔU)** [calculated value]

* Applicable only at test current 10 A.

** Applicable only at ΔU test set to On

Specific options

	Calibrate - Compensation of test lead / IEC test cable resistance. Refer to chapter 6.2.2.1 for procedure details.
	Lim. Calculator – Continuity resistance H Limit(R) calculator. Refer to chapter 6.2.2.2 for details.

Test circuit



Figure 6.16: Continuity MS PE – IEC PE

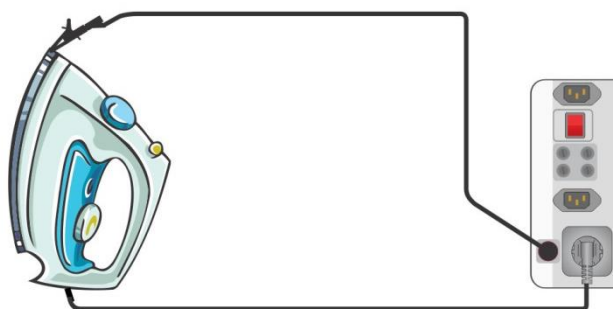

Figure 6.17: Continuity P/S – PE

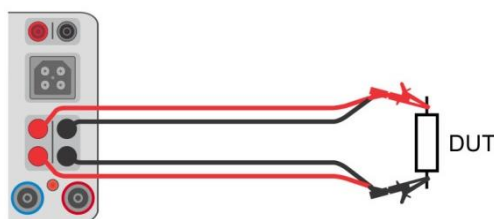

Figure 6.18: Measurement of continuity 4-wire

Continuity measurement procedure

- › Select the **Continuity** function.
- › Set test parameters / limits.
- › Connect test leads to the instrument output terminals (C1, P1 and C2, P2 (4 wire), P/S – PE (2 wire), MS PE – IEC PE, see Test circuit figures).
- › Compensate test leads resistance (optional), see chapter **6.2.2.1 Compensation of test leads resistance** for details.
- › Connect test leads to the device under test, see Test circuit figures.
- › Start measurement.
- › Measurement can be stopped manually or by timer – duration parameter.
- › Save results (optional).

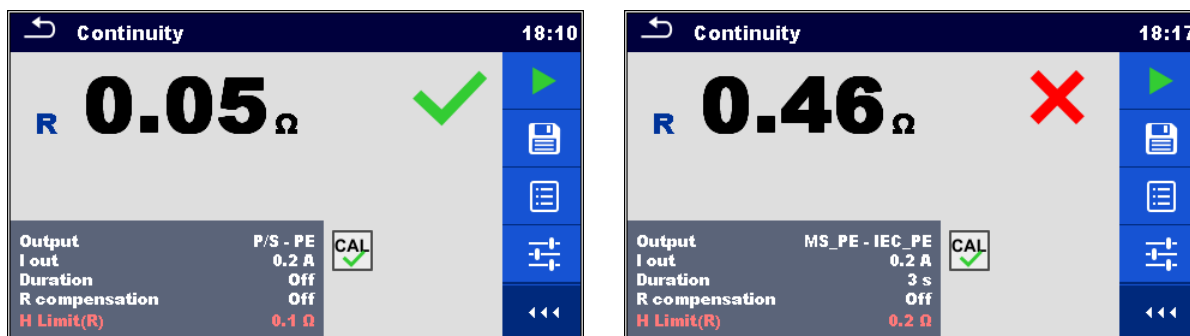

Figure 6.19: Examples of Continuity measurement results

6.2.2.1 Compensation of test leads resistance (Continuity, PE conductor (PRCD))

This chapter describes how to compensate the test leads resistance in **Continuity** and **PE_conductor (PRCD)** functions. Compensation can be carried out to eliminate the influence of test leads resistance and the internal resistances of the instrument and adapters on the measured resistance.

Connections for compensating the resistance of test leads

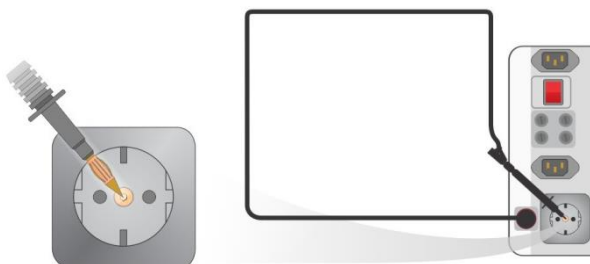



Figure 6.20: Compensation between mains test socket and P/S



Figure 6.21: Compensation between mains test socket and IEC socket

Compensation of test leads resistance procedure

- › Select the **Continuity** function
- › Set parameters (Output, Test current).
- › Connect test lead to the instrument between P/S and PE terminal on test socket (**Figure 6.20**) or connect IEC test cable between IEC connector and test socket (**Figure 6.21**).

Touch the  key to compensate test lead / IEC test cable resistance.

- › Symbol  is displayed if the compensation was carried out successfully.

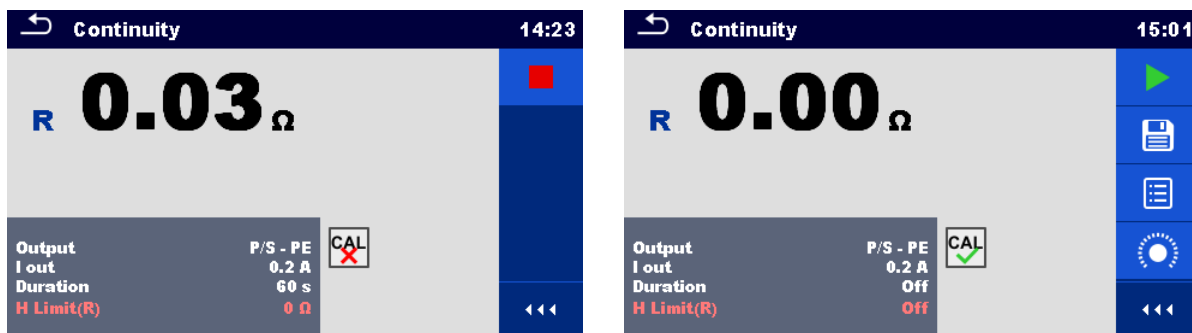



Figure 6.22: Uncompensated and compensated test result

Notes:

- The compensation value is correct only for the output at which it was carried out.
- The compensation of test leads is carried out with set test current (I out).
- For manual compensation in Continuity function, set R compensation parameter. Set value is decremented from the measured value. (Recommended for 4 wire Continuity measurement with 2 wire extension leads.) Max. allowed R compensation value is 2 Ω.

6.2.2.2 Limit Calculator

It is useful tool to determine continuity resistance high limit, especially when testing mains power extension cords with or without PRCDs.

Limit calculator  is included in Continuity and PE_conductor (PRCD) functions and can be accessed from options panel.

Limit Calculator screens are presented on **Figure 6.23**.

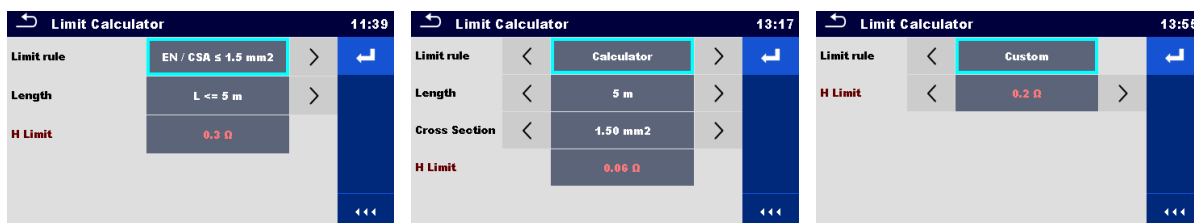

Figure 6.23: Limit Calculator screens

Four Limit rules are offered:

A: EN / CSA ≤ 1.5 mm²

Continuity and PE_conductor(PRCD) resistance limit is set in accordance with the EN 50678 and EN 50699 standards, for cross section areas up to 1.5 mm².

L wire length	R Limit [Ω]
L ≤ 5 m	0.3
5 m < L ≤ 12.5 m	0.4
12.5 m < L ≤ 20 m	0.5
20 m < L ≤ 27.5 m	0.6
27.5 m < L ≤ 35 m	0.7
35 m < L ≤ 42.5 m	0.8
42.5 m < L ≤ 50 m	0.9
50 m < L ≤ 57.5 m	1.0

B: Calculator

Continuity and PE_conductor(PRCD) resistance limit is calculated by the formula:

$$R = \rho \frac{L}{A}$$

Where:

- ρ..... specific resistance of copper 1,68×10⁻⁸ Ωm
- L..... wire length selected from a list (1 m, 2 m, 3 m, ... ,100 m) or Custom numeric entry
- A..... wire cross section selected from a list (0.50 mm², 0.75 mm², 1.00 mm², 1.50 mm², 2.5 mm², 4.0 mm², 10.0 mm²) or Custom numeric entry

C: NEN 3140

Continuity and PE_conductor(PRCD) resistance limit is derived from table on wire length and wire cross-section basis. Table is based on NEN 3140 standard.

L wire length	Wire cross-section [mm ²]						
	1.5	2.5	4	6	10	16	25
R Limit [Ω]							
L <= 2 m	0.22	0.21	0.21	0.21	0.20	0.20	0.20
2 m < L <= 5 m	0.26	0.24	0.22	0.21	0.21	0.21	0.20
5 m < L <= 10 m	0.32	0.27	0.24	0.23	0.22	0.21	0.21
10 m < L <= 15 m	0.38	0,31	0.27	0.24	0.23	0.22	0.21
15 m < L <= 20 m	0.43	0.34	0.29	0.26	0.24	0.22	0.21
20 m < L <= 25 m	0.49	0.38	0.31	0.27	0.24	0.23	0.22
25 m < L <= 30 m	0.55	0.41	0.33	0.29	0.25	0.23	0.22
30 m < L <= 35 m	0.61	0.45	0.35	0.30	0.26	0.24	0.22
35 m < L <= 40 m	0.67	0.48	0.38	0.32	0.27	0.24	0.23
40 m < L <= 45 m	0.73	0.52	0.40	0.33	0.28	0.25	0.23
45 m < L <= 50 m	0.78	0.55	0.42	0.35	0.29	0.25	0.24

D: Custom

Continuity and PE_conductor(PRCD) resistance limit is directly selected from a list (Off, 0.01 Ω ... 0.09 Ω, 0.1 Ω ... 0.9 Ω, 1 Ω ... 9 Ω) or H Limit Custom numeric entry.

Procedure and parameter selection

①  Select Limit Calculator from options panel of Continuity or PE_conductor(PRCD) test screen to open Limit Calculator screen.

②  Select Limit rule by using on-screen or keyboard arrow keys.

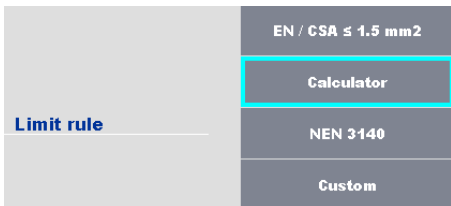
 Alternatively, selection is possible from the list. By taping on the Limit rule field, list of available Limit rules is presented. Tap on the chosen rule field and screen returns to Limit Calculator.



Select parameters value for chosen Limit rule by using on-screen or keyboard arrow keys.

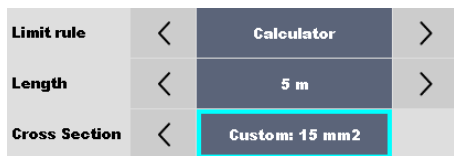

By tapping on parameter field, value can be selected from presented list.

Calculator rule allow custom value Length and Cross section entry with on-screen keyboard, when Custom is selected from the value list.

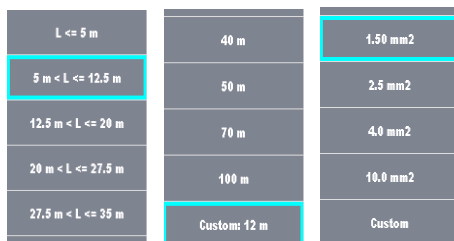

Examples of parameter value lists:
 -EN / CSA ≤ 1.5 mm² rule Length parameter list
 -Calculator rule Length parameter list
 -Calculator rule Cross section parameter list.

Speed up parameters selection with:
 -using scroll bar on the right side of the screen,
 -keyboard right / left keys for page up / down.

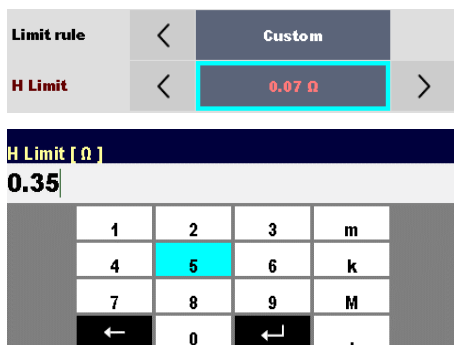

Custom rule is intended for direct H Limit entry.

Select value from the list:
 - by using arrow keys,
 - tap on the field to open list and chose value,
 -or enter value with on-screen keyboard after Custom value is selected from the list.

Example of on-screen numeric keyboard – direct H Limit custom value entry.



Apply option selection from Limit Calculator options bar automatically overwrite H Limit(R) parameter of selected single test - Continuity or PE_conductor(PRCD).

6.2.3 Insulation resistance RPAT (Portable appliance)

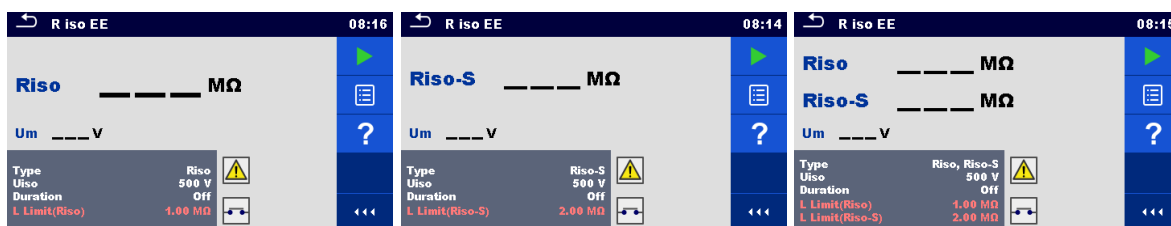

Figure 6.24: Insulation resistance (Portable appliance) test menus

Test results / sub-results

- Riso Insulation resistance
- Riso-S Insulation resistance-S
- Um Test voltage

Test parameters

Type	Type of test [Riso, Riso-S, (Riso, Riso-S)]
------	---

Uiso	Nominal test voltage [250 V, 500 V]
Duration	Duration [Off, 2 s ... 180 s]

Test limits

L limit(Riso)	Low limit (Riso) [Off, Custom, 0.01 MΩ ... 10.0 MΩ]
L limit(Riso-S)	Low limit (Riso-S) [Off, Custom, 0.10 MΩ ... 10.0 MΩ]

Test circuits



Figure 6.25: Insulation resistance Riso (socket)

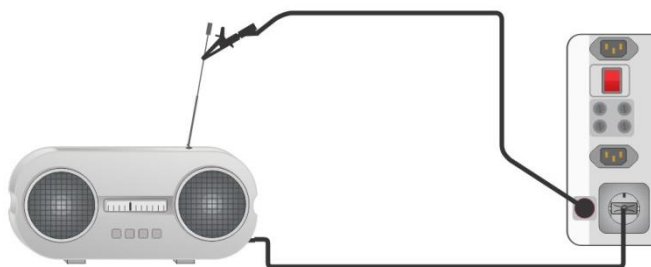

Figure 6.26: Insulation resistance Riso-S

R_{PAT} measurement procedure

- › Select the **Riso** function (portable appliance).
- › Set test parameters / limits.
- › Connect device under test to the instrument (see test circuits above).
- › Start measurement.
- › Measurement can be stopped manually or by timer.
- › Save results (optional).

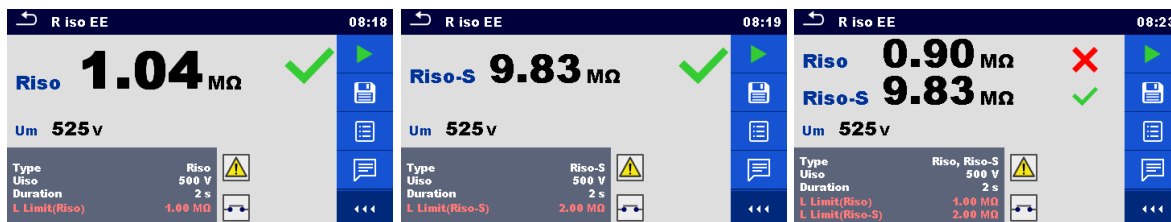

Figure 6.27: Examples of Insulation resistance (Portable appliance) measurement results

Note:

- › The current through the P/S probe is also considered in the Riso result.

6.2.4 Insulation resistance Rw (Welding equipment)

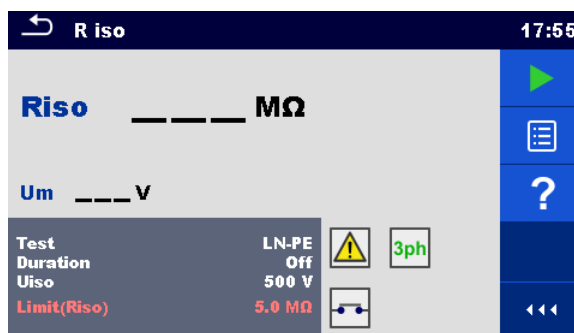

Figure 6.28: Insulation resistance (Welding equipment) test menus

Test results / sub-results

Riso Insulation resistance
 Um Test voltage

Test parameters

Test	Test type [LN-W, W-PE, LN-PE, LN (Class II) – P/S]
Duration	Duration [Off, 2 s ... 180 s]
Uiso	Nominal test voltage [500 V]dc

Test limits

Limit (Riso)	Low Limit (Riso) [Off, Custom, 2.5 MΩ, 5.0 MΩ]
--------------	--

Test circuit, measurement procedure

- › Select the **Riso** function (welding equipment).
- › Set test parameters / limits.
- › Connect METREL 3-phase adapter (A 1422) to the instrument*.
- › Connect device under test to the 3-phase adapter*.
- › Start measurement.
- › Measurement can be stopped manually or by timer.
- › Save results (optional).

*For more information refer to chapter *Measurements according to IEC/ EN 60974-4 – Insulation resistance* in 3-phase adapter instruction manual.

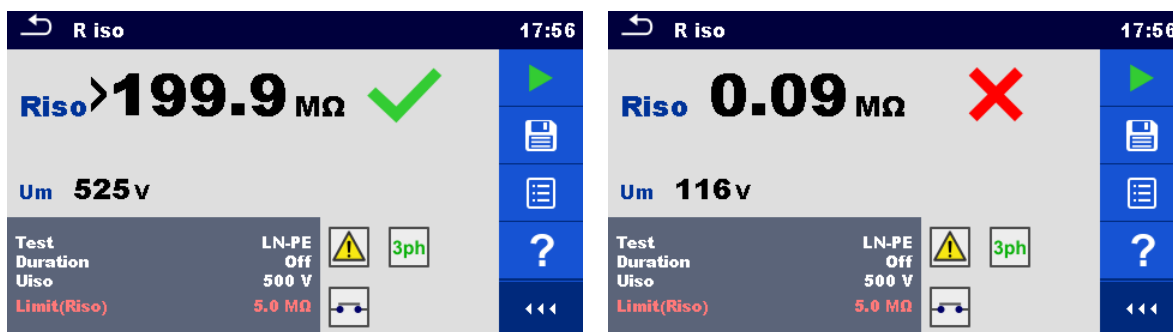

Figure 6.29: Examples of Insulation resistance (Welding equipment) measurement results

Note:

- This test is applicable only with connected METREL 3-phase adapter (A1422).

6.2.5 Insulation resistance ISO (Installations)

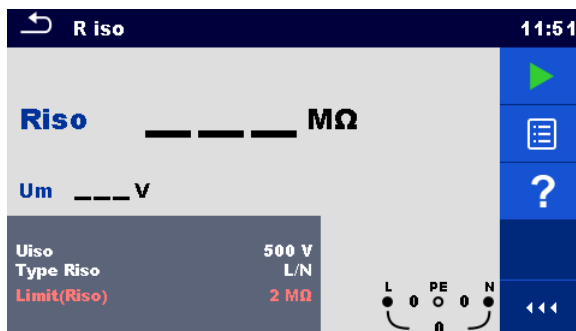

Figure 6.30: Insulation resistance (Installations) measurement menu

Test results / sub-results

Riso Insulation resistance

Um Actual test voltage

Test parameters

Uiso	Nominal test voltage [50V, 100V, 250V, 500V, 1000V]
Type Riso¹⁾	Type of test [-, L/PE, L/N, N/PE, L/L, L1/L2, L1/L3, L2/L3, L1/N, L2/N, L3/N, L1/PE, L2/PE, L3/PE]

Test limits

Limit(Riso)	Low Limit (Riso) [Off, Custom, 0.01 MΩ ... 100 MΩ]
--------------------	--

¹⁾ Insulation measurement terminals depends on Type Riso setting, see table below.

Type Riso parameter	Test leads terminals
-	
L-N	
Lx-N	L and N
L-L	
Lx-Ly	
L-PE	L and PE
Lx-PE	
N-PE	N and PE

Table 6.1: Insulation resistance measuring terminals and Type Riso parameter dependency

Connection diagrams

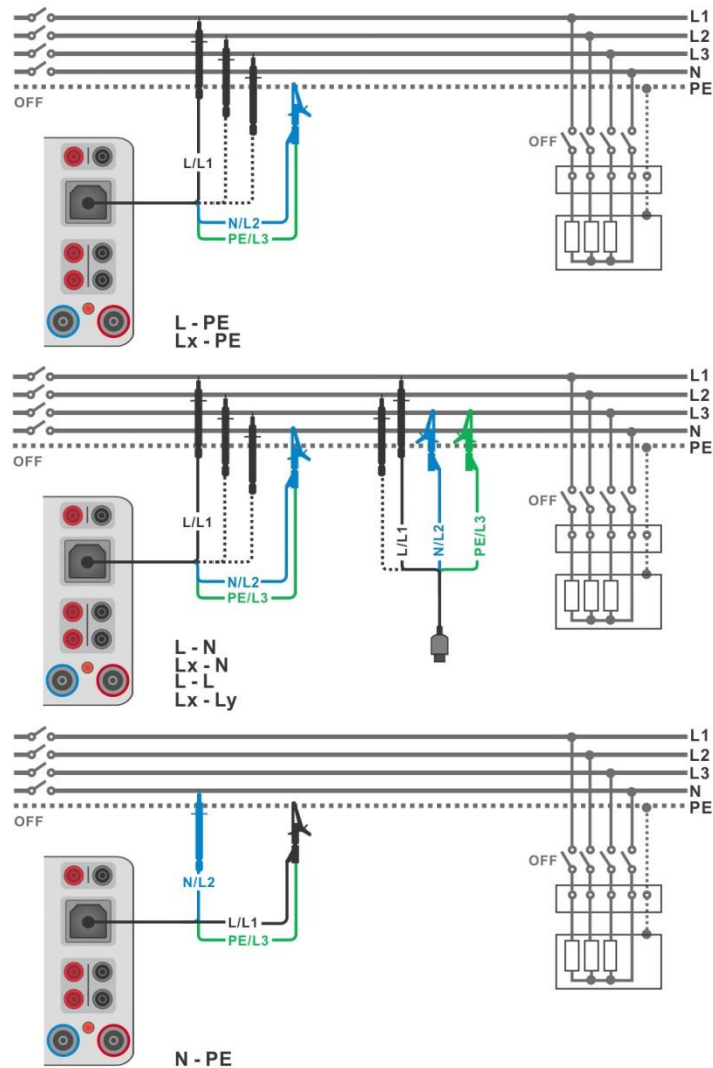

Figure 6.31: Connections of 3-wire test lead

Measurement procedure

- › Enter the **Riso** function (installation).
- › Set test parameters / limits.
- › Disconnect tested installation from mains supply and discharge installation as required.
- › Connect test cable to the instrument.
- › Connect 3-wire test lead to object under test. (See **Figure 6.31**).
- › Start the measurement. A longer press on **ENTER** key or a longer press on **▶** option on touch screen starts a continuous measurement.
- › Stop the measurement. Wait until object under test is fully discharged.
- › Save results (optional).



Figure 6.32: Examples of Insulation resistance (Installations) measurement result

6.2.5.1 Load pretest

High Insulation voltage can potentially damage the connected appliances during the Insulation measurement. This misuse can be prevented by enabling Load pretest functionality in Settings menu. Load pretest measures the impedance on test terminals with low and safe a.c. voltage. If impedance lower than 50 kΩ is detected, warning message is displayed, allowing to disconnect the appliances before test voltage is applied (see **Figure 6.33**: Load pretest warning message). Insulation measuring voltage is applied to the test terminals only after YES is selected. NO will abort the measurement.

If impedance higher than 50 kΩ is measured during the Load pretest, Insulation test will follow automatically.

Test function	Type Riso parameter	Load pretest terminals
Riso	-	
	L/N	
	Lx/N	L-N
	L/L	
	Lx/Ly	
	L/PE	L-PE
	Lx/PE	
	N/PE	N-PE

Table 6.2: Insulation resistance measuring terminals and Load pretest dependency

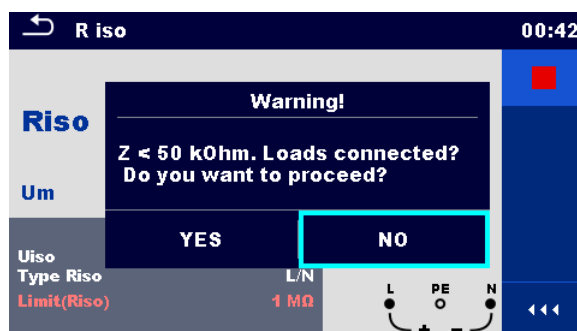

Figure 6.33: Load pretest warning message

6.2.6 Varistor test

A voltage ramp starts from 50 V and rises with a slope of 100 V/s. The measurement ends when the defined end voltage is reached or if the test current exceeds the value of 1 mA.

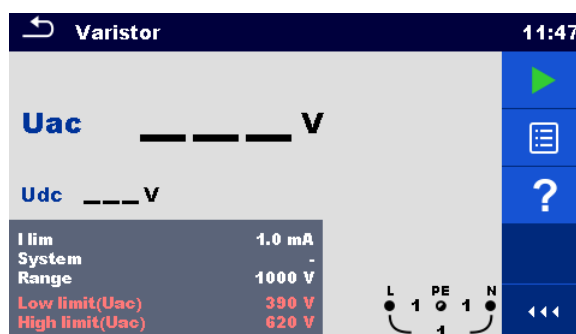

Figure 6.34: Varistor test main menu

Test results / sub-results

Uac..... Calculated a.c. breakdown voltage

Udc Breakdown voltage

Test parameters

I lim	Current limit [1.0 mA]
System	System [-, TT, TN, TN-C, TN-S]
Range	Test voltage range [1000 V]

Test limits

Low limit(Uac)	Low breakdown limit value (Uac) [Off, 50 V ... 620 V]
High limit (Uac)	High breakdown limit value (Uac) [Off, 50 V ... 620 V]

Test circuit for Varistor test

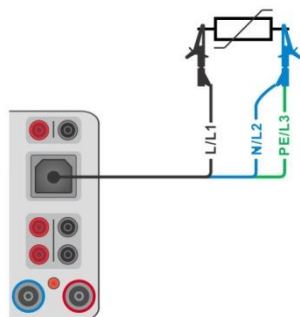

Figure 6.35: Connection of 3-wire test lead

Measurement procedure

- › Enter the **Varistor test** function.
- › Set test parameters / limits.
- › Connect test cable to the instrument.
- › Connect 3-wire test lead to object under test, see **Figure 6.35**.
- › Start the measurement.
The measurement ends when the defined end voltage is reached or if the test current exceeds the value of 1 mA.
- › After the measurement is finished wait until tested item is fully discharged.
- › Save results (optional).

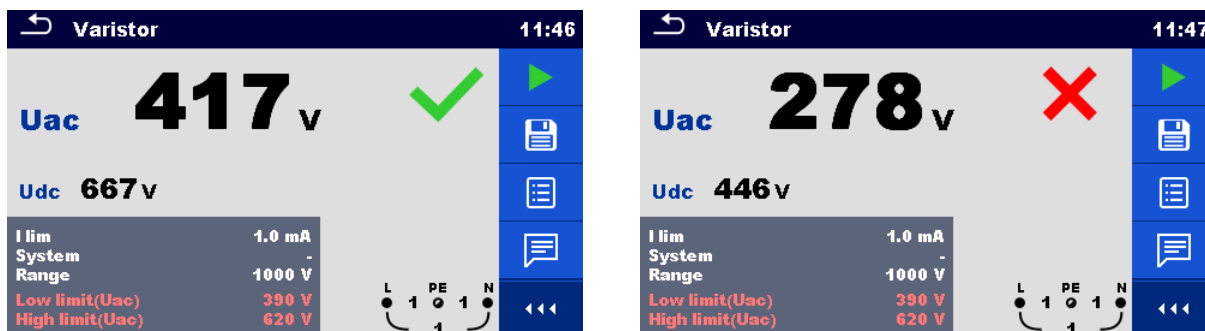

Figure 6.36: Examples of Varistor test result

Meaning of the Uac voltage

Protection devices intended for a.c. network are usually dimensioned approx. 15 % above peak value of the nominal mains voltage. The relation between Udc and Uac is following:

$$Uac \approx \frac{Udc}{1.15 \times \sqrt{2}}$$

Uac voltage may be directly compared with the voltage declared on tested protection device.

6.2.7 Sub-leakage (Isub, Isub-S)

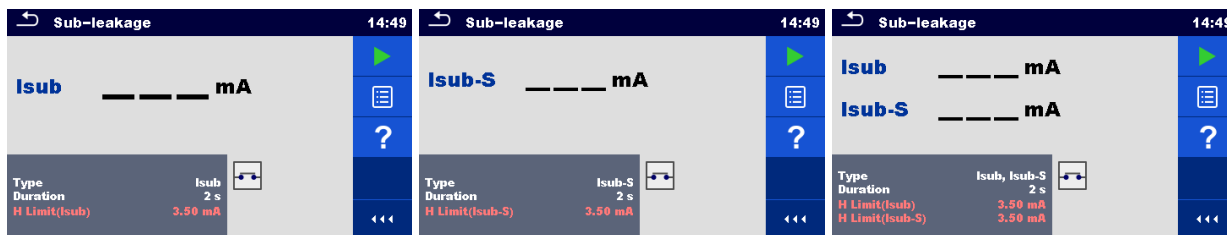

Figure 6.37: Sub Leakage test menus

Test results / sub-results

Isub..... Sub-leakage current

Isub-S Sub-leakage current-S

Test parameters

Type	Type of test [Isub, Isub-S, (Isub, Isub-S)]
Duration	Duration [Off, 2 s ... 180 s]

Test limits

H Limit(Isub)	High Limit (Isub) [Off, Custom, 0.25 mA ... 15.0 mA]
H Limit(Isub-S)	High Limit (Isub-S) [Off, Custom, 0.25 mA ... 15.0 mA]

Test circuits

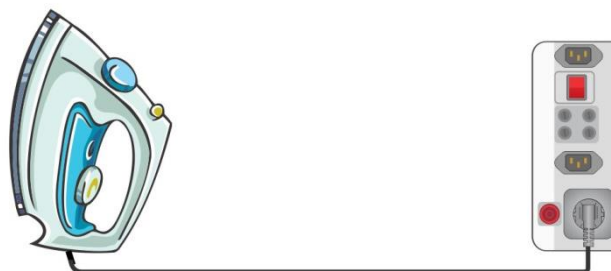

Figure 6.38: Sub-leakage

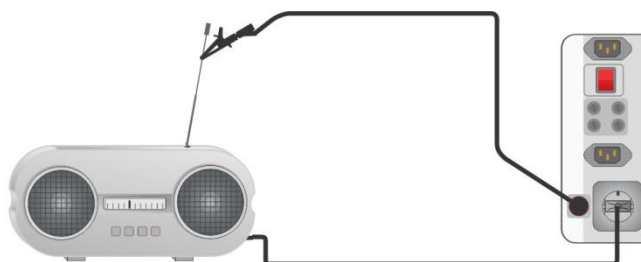

Figure 6.39: Sub-leakage-S

Sub-leakage measurement procedure

- › Select the **Sub-leakage** function.
- › Set test parameters / limits.
- › Connect device under test to the instrument (see test circuits above).
- › Start measurement.

- › Measurement can be stopped manually or by timer.
- › Save results (optional).

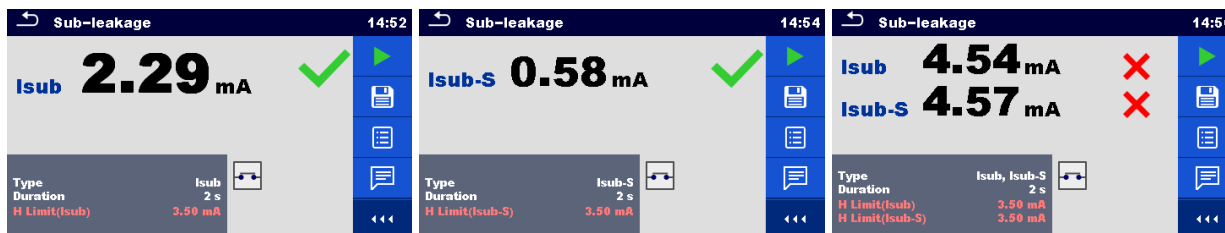

Figure 6.40: Examples of Sub-leakage measurement results

Note:

- › When P/S probe is connected during the Sub-leakage measurement, then the current through it is also considered.

6.2.8 Differential Leakage

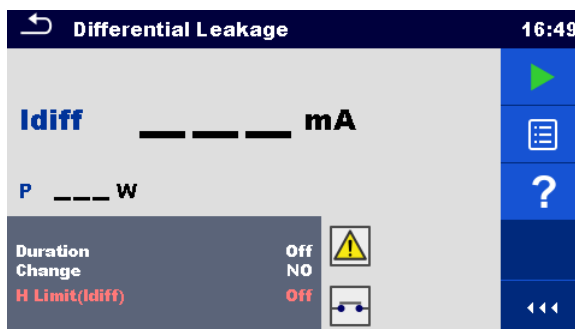

Figure 6.41: Differential Leakage test menu

Test results / sub-results

Idiff..... Differential Leakage current
P..... Power

Test parameters

Duration	Duration [Off, 2 s ... 180 s]
Change	Change status [YES, NO] YES: The instrument measures leakage current in two sequential steps with delay* in between. The phase voltage is firstly applied to the right live output of the mains test socket and secondly to the left live output of the mains test socket. NO: The phase voltage is applied only to the right live output of the mains test socket.
Delay	*Delay time [0.2 s ... 5 s]

Test limits

H Limit(Idiff)	High Limit (Idiff) [Off, Custom, 0.25 mA ... 15.0 mA]
-----------------------	---

Test circuit

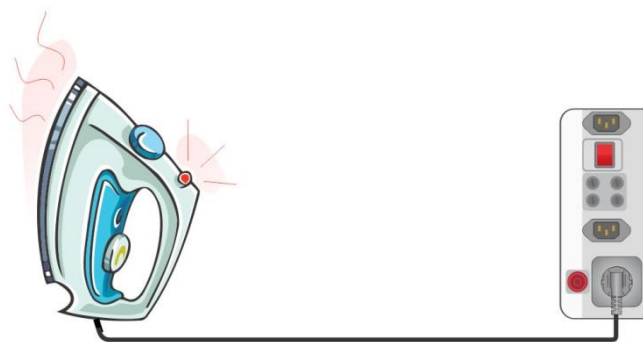

Figure 6.42: Differential leakage test

Differential Leakage measurement procedure

- › Select the **Differential Leakage** function.
- › Set test parameters / limits.
- › Connect device under test to the instrument (see test circuits above).
- › Start measurement.
- › Measurement can be stopped manually or by timer.
- › Save results (optional).

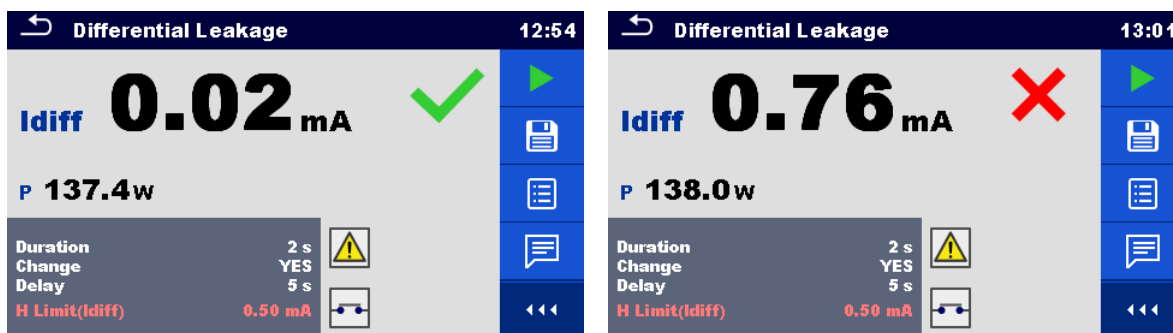

Figure 6.43: Examples of Differential Leakage measurement results

6.2.9 Ipe Leakage

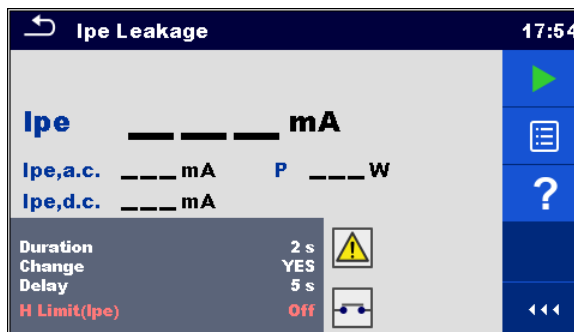

Figure 6.44: Ipe Leakage test menu

Test results / sub-results

- Ipe** PE current
- Ipe,a.c.** a.c. part of PE current

I_{pe,d.c.}..... d.c. part of PE current
 P..... Power

Test parameters

Duration	Duration [Off, 2 s ... 180 s]
Change	Change status [YES, NO] YES: The instrument measures leakage current in two sequential steps with delay* in between. The phase voltage is firstly applied to the right live output of the mains test socket and secondly to the left live output of the mains test socket. NO: The phase voltage is applied only to the right live output of the mains test socket.
Delay	*Delay time [0.2 s ... 5 s]

Test limits

H Limit(I_{pe})	High Limit (I _{pe}) [Off, Custom, 0.25 mA ... 15.0 mA]
--------------------------------	--

Test circuit

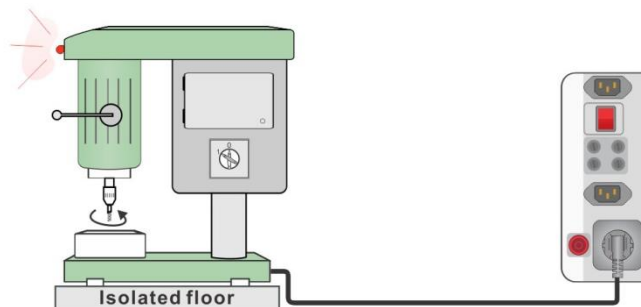

Figure 6.45: I_{pe} leakage

I_{pe} Leakage measurement procedure

- › Select the **I_{pe} Leakage** function.
- › Set test parameters / limits.
- › Connect device under test to the instrument (see test circuits above).
- › Start measurement.
- › Measurement can be stopped manually or by timer.
- › Save results (optional).



Figure 6.46: Examples of I_{pe} Leakage measurement results

6.2.10 Touch Leakage

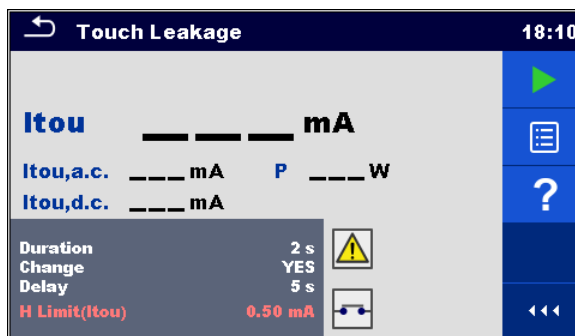

Figure 6.47: Touch Leakage test menu

Test results / sub-results

Itou..... Touch Leakage current
Itou,a.c...... a.c. part of Touch Leakage current
Itou,d.c...... d.c. part of Touch Leakage current
P..... Power

Test parameters

Duration	Duration [Off, 2 s ... 180 s]
Change	Change status [YES, NO] YES: The instrument measures leakage current in two sequential steps with delay* in between. The phase voltage is firstly applied to the right live output of the mains test socket and secondly to the left live output of the mains test socket. NO: The phase voltage is applied only to the right live output of the mains test socket.
Delay	*Delay time [0.2 s ... 5 s]

Test limits

H Limit(Itou)	High Limit (Itou) [Off, Custom, 0.25 mA ... 15.0 mA]
----------------------	--

Test circuit



Figure 6.48: Touch leakage current test connection

Touch Leakage measurement procedure

- › Select the **Touch Leakage** function.
- › Set test parameters / limits.
- › Connect device under test to the instrument (see test circuits above).
- › Start measurement.
- › Measurement can be stopped manually or by timer.
- › Save results (optional).

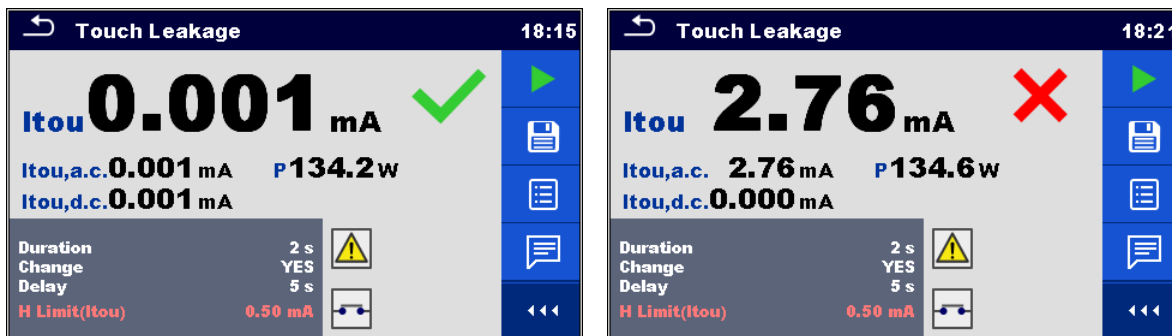

Figure 6.49: Examples of Touch Leakage measurement results

6.2.11 Welding Circuit Leakage I leak (W-PE)

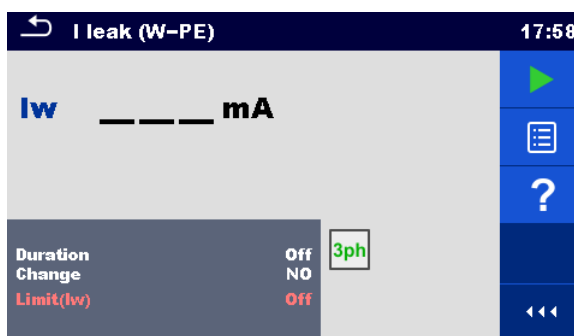

Figure 6.50: Welding Circuit Leakage test menu

Test results / sub-results

Iw Welding circuit Leakage current

Test parameters

Duration	Duration [Off, 2 s ... 180 s]
Change	Change status [YES, NO] YES: The instrument measures leakage current in two sequential steps with delay* in between. The phase voltage is firstly applied to the right live output of the mains test socket and secondly to the left live output of the mains test socket. NO: The phase voltage is applied only to the right live output of the mains test socket.
Delay	*Delay time [0.2 s ... 5 s]

Test limits

Limit (Iw)	Limit(Iw) [Off, Custom, 3.5 mA ... 10 mA]
-------------------	---

Test circuit, I leak (W-PE) measurement procedure

- › Select the **I leak (W-PE)** function.
- › Set test parameters / limits.
- › Connect METREL 3-phase adapter (A 1422) to the instrument*.
- › Connect device under test to the 3-phase adapter*.
- › Start measurement.
- › Measurement can be stopped manually or by timer.
- › Save results (optional).

*For more information refer to chapter *Measurements according to IEC/ EN 60974-4 – Welding circuit leakage current* in 3-phase adapter user manual.

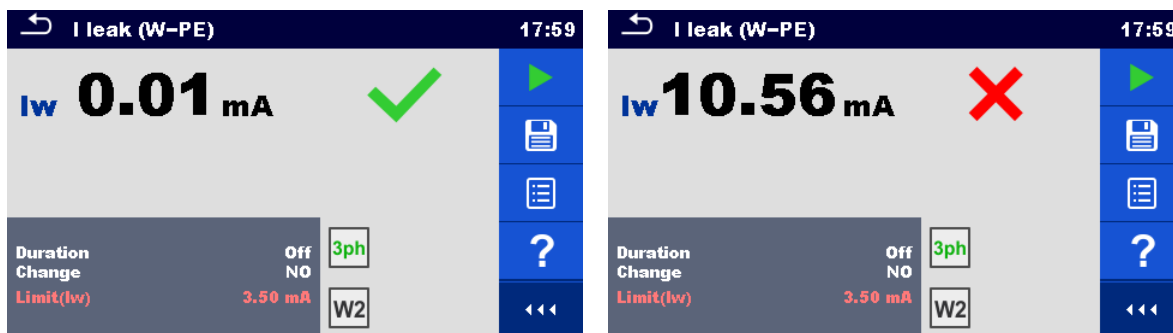

Figure 6.51: Examples of Welding Circuit Leakage measurement results

Note:

- › This test is applicable only with connected METREL 3-phase adapter (A1422).

6.2.12 Protective conductor current I_{primW}

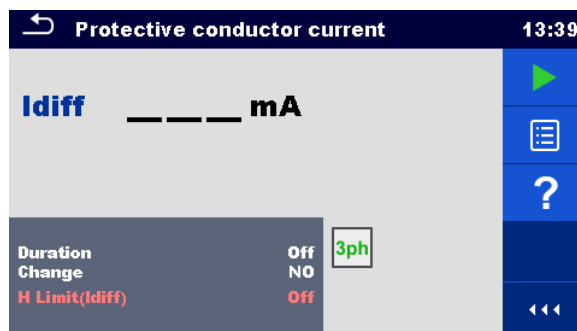

Figure 6.52: Protective conductor current menu

Test results / sub-results

Idiff..... Protective conductor current

Test parameters

Duration	Duration [Off, 2 s ... 180 s]
Change	Change status [YES, NO] YES: The instrument measures Protective conductor current in two sequential steps with delay* in between. The phase voltage is firstly applied to the right live output of the mains test socket and secondly to the left live output of the mains test socket. NO: The phase voltage is applied only to the right live output of the mains test socket.
Delay	*Delay time [0.2 s ... 5 s]

Test limits

H Limit(Idiff)	High limit I_{primW} [Off, Custom, 0.25 mA ... 15.0 mA]
-----------------------	---

Test circuit, Protective conductor current measurement procedure

- › Select the **Protective conductor current** function.
- › Set test parameters / limits.
- › Connect METREL 3-phase adapter (A 1422) to the instrument*.

- › Connect device under test to the 3-phase adapter*.
- › Start measurement.
- › Measurement can be stopped manually or by timer.
- › Save results (optional).

*For more information refer to chapter *Measurements according to IEC/ EN 60974-4 – Protective conductor current in 3-phase adapter* user manual.

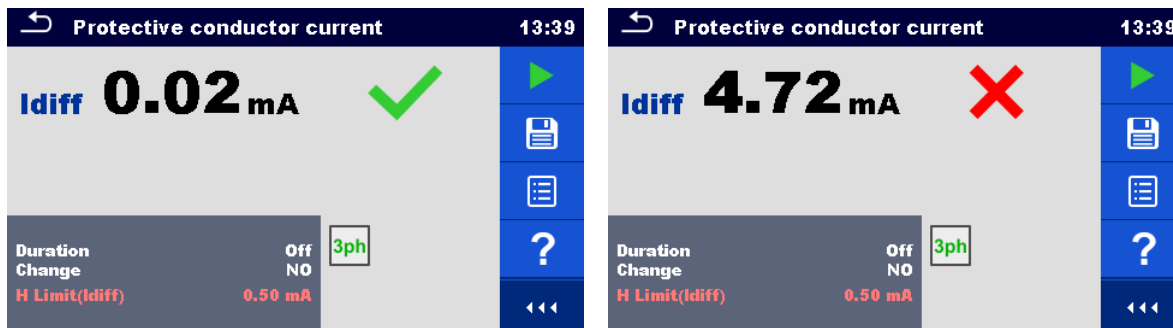

Figure 6.53: Examples of Protective conductor current measurement results

Note:

- › This test is applicable only with connected METREL 3-phase adapter (A1422).
- › The differential current measurement principle is used for this test.

6.2.13 Leak's & Power

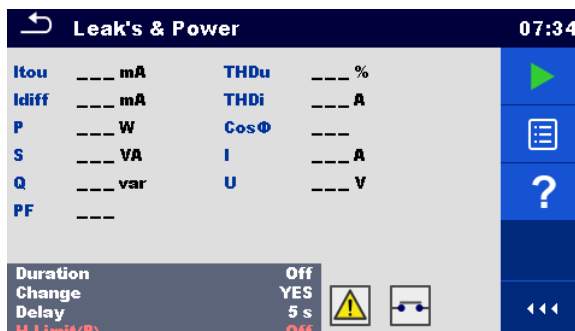

Figure 6.54: Leak's & Power measurement menu

Test results / sub-results

- Itou**..... Touch Leakage current
- Idiff**..... Differential Leakage current
- P**..... Active power
- S**..... Apparent power
- Q**..... Reactive power
- PF**..... Power factor
- THDu**..... Total harmonic distortion – voltage
- THDi**..... Total harmonic distortion – current
- Cos Φ**..... cosines Φ
- I**..... Load current
- U**..... Voltage

Test parameters

Duration	Duration [Off, 2 s ... 180 s]
-----------------	-------------------------------

Change	Change status [YES, NO] YES: The instrument measures leakage current in two sequential steps with delay* in between. The phase voltage is firstly applied to the right live output of the mains test socket and secondly to the left live output of the mains test socket. NO: The phase voltage is applied only to the right live output of the mains test socket.
Delay	*Delay time [0.2 s ... 5 s]

Test limits

H limit(P)	High Limit (P) [Off, Custom, 10 W ... 3.50 kW]
L limit(P)	Low Limit (P) [Off, Custom, 10 W ... 3.50 kW]
H limit(Idiff)	High Limit (Idiff) [Off, Custom, 0.25 mA ... 15.0 mA]
H limit(Itou)	High Limit (Itou) [Off, Custom, 0.25 mA ... 15.0 mA]

Test circuit

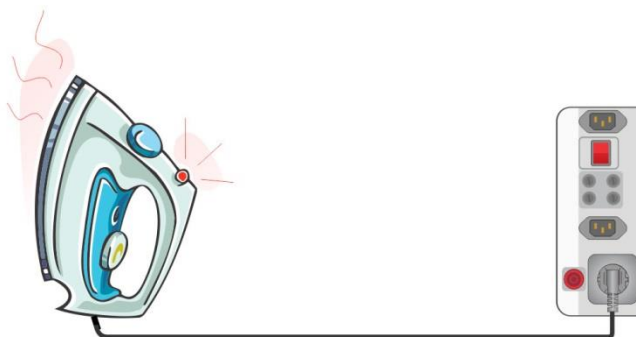

Figure 6.55: Measurement of Leak's and Power

Leak's & Power measurement procedure

- › Select the **Leak's & Power** function.
- › Set test parameters / limits.
- › Connect device under test to the instrument (see test circuit above).
- › Start measurement.
- › Measurement can be stopped manually or by timer.
- › Save results (optional).

The figure shows two screenshots of the instrument's 'Leak's & Power' measurement results screen. The left screenshot, taken at 09:09, shows a successful measurement with green checkmarks for most parameters: Itou (0.001 mA), THDu (2.7%), Idiff (0.03 mA), THDi (215 mA), P (1835 W), CosΦ (1.00c), S (1835 VA), I (8.34 A), Q (38.1 var), U (220 V), and PF (1.00). The H Limit(P) is set to 2.00 kW. The right screenshot, taken at 09:13, shows a failed measurement with red X marks for Idiff (0.01 mA), THDi (413 mA), P (935 W), I (4.23 A), and S (943 VA). The H Limit(P) is set to 450 W. Both screens display test parameters, duration (5 s), change status (YES), delay (5 s), and a warning icon.

Figure 6.56: Examples of Leak's & Power measurement results

6.2.14 Power

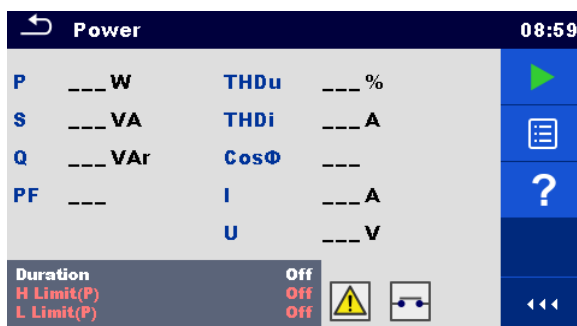

Figure 6.57: Power measurement menu

Test results / sub-results

- P..... Active power
- S..... Apparent power
- Q Reactive power
- PF..... Power factor
- THDu..... Total harmonic distortion – voltage
- THDi..... Total harmonic distortion – current
- Cos Φ..... cosines Φ
- I Load current
- U..... Voltage

Test parameters

Duration	Duration [Off, 2 s ... 180 s]
-----------------	-------------------------------

Test limits

H limit(P)	High Limit (P) [Off, Custom, 10 W ... 3.50 kW]
L limit(P)	Low Limit (P) [Off, Custom, 10 W ... 3.50 kW]

Test circuit



Figure 6.58: Power measurement

Power measurement procedure

- › Select the **Power** function.
- › Set test parameters / limits.
- › Connect device under test to the instrument (see test circuits above).
- › Start measurement.
- › Measurement can be stopped manually or by timer.
- › Save results (optional).

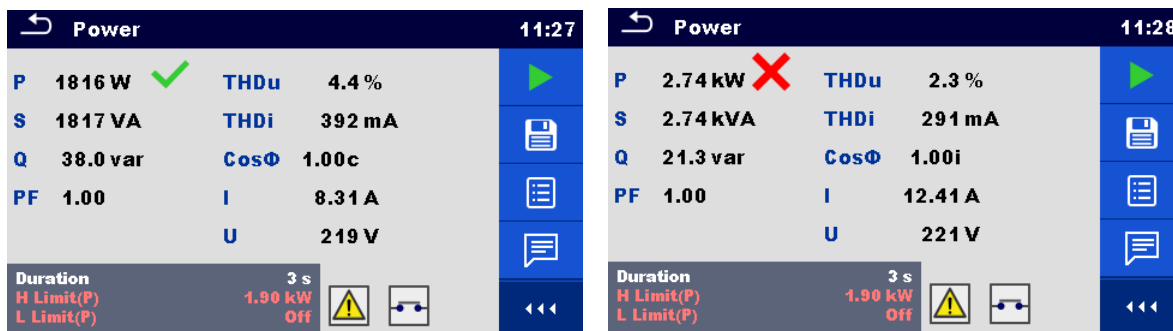

Figure 6.59: Examples of Power measurement results

6.2.15 Voltage, frequency and phase sequence

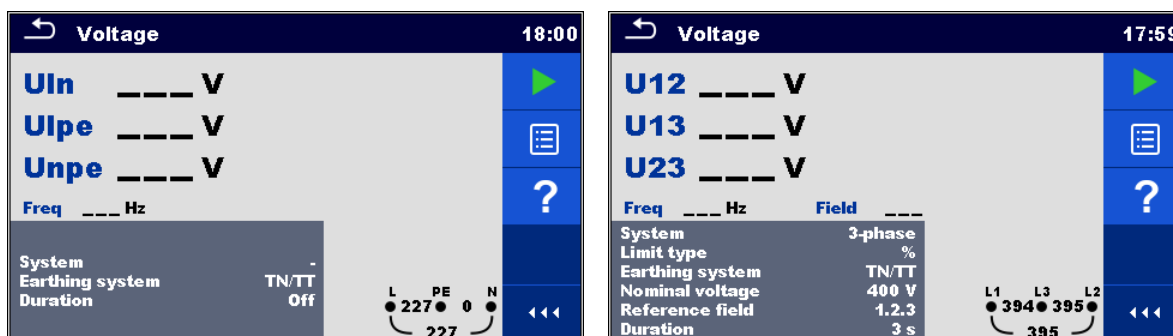

Figure 6.60: Examples of Voltage measurement menu

Test results / sub-results

Single-phase TN/TT system:

Uln	Voltage between phase and neutral conductors
Ulpe	voltage between phase and protective conductors
Unpe	voltage between neutral and protective conductors
Freq	frequency

Single phase IT system:

U12	voltage between phases L1 and L2
U1pe	voltage between phase L1 and PE
U2pe	voltage between phase L2 and PE
Freq	frequency

Three-phase TN/TT and IT system:

U12	voltage between phases L1 and L2
U13	voltage between phases L1 and L3
U23	voltage between phases L2 and L3
Freq	frequency
Field	1.2.3 - correct connection – CW rotation sequence 3.2.1 - invalid connection – CCW rotation sequence

Test parameters

System ¹⁾	Voltage system [-, 1-phase,3-phase]
Test ³⁾	Phase to be tested [-, L1, L2, L3]
Limit type	Type of limit [Voltage, %]
Earthing system	Earthing system [TN/TT, IT] Refer to chapter 4.7.3 Settings for more information.
Nominal voltage ²⁾	Nominal voltage [Custom, 110 V, 115 V, 190 V, 200 V, 220 V, 230 V, 240 V, 380 V, 400 V, 415 V]
Reference field ⁴⁾	Correct phase rotation [-, 1.2.3, 3.2.1]
Duration	Test duration [Off, Custom, 1 s, 3 s, 5 s]

1) There are no limits to set if System parameter is set to '-'.
2) Active only if limit type parameter is set to %.

3) Active only when System is set to 1-phase.

4) Active only when system is set to 3-phase; set parameter (1.2.3 or 3.2.1) to verify correct phase sequence during Voltage test.

Test limits for TN/TT earthing system:

Low limit(UIn) ⁵⁾	Min. voltage (UIn) [Off, Custom, 0 V ... 499 V]
High limit(UIn) ⁵⁾	Max. voltage (UIn) [Off, Custom, 0 V ... 499 V]
Low limit(UIn) ⁶⁾	Min. voltage (UIn) [Off, Custom, -20% ... 20%]
High limit(UIn) ⁶⁾	Max. voltage (UIn) [Off, Custom, -20% ... 20%]
Low limit(Ulpe) ^{5,6)}	Min. voltage (Ulpe) [Off, Custom, 0 V ... 499 V]
High limit(Ulpe) ^{5,6)}	Max. voltage (Ulpe) [Off, Custom, 0 V ... 499 V]
Low limit(Unpe) ^{5,6)}	Min. voltage (Unpe) [Off, Custom, 0 V ... 499 V]
High limit(Unpe) ^{5,6)}	Max. voltage (Unpe) [Off, Custom, 0 V ... 499 V]
Low limit(U12) ⁷⁾	Min. voltage (U12) [Off, Custom, 0 V ... 499 V]
High limit(U12) ⁷⁾	Max. voltage (U12) [Off, Custom, 0 V ... 499 V]
Low limit(U13) ⁷⁾	Min. voltage (U13) [Off, Custom, 0 V ... 499 V]
High limit(U13) ⁷⁾	Max. voltage (U13) [Off, Custom, 0 V ... 499 V]
Low limit(U23) ⁷⁾	Min. voltage (U23) [Off, Custom, 0 V ... 499 V]
High limit(U23) ⁷⁾	Max. voltage (U23) [Off, Custom, 0 V ... 499 V]
Low limit(U12,U13,U23) ⁸⁾	Min. voltage (U12,U13,U23) [Off, Custom, -20% ... 20%]
High limit(U12,U13,U23) ⁸⁾	Max. voltage (U12,U13,U23) [Off, Custom, -20% ... 20%]

5) In case of 1-phase voltage system and limit type set to voltage.

6) In case of 1-phase voltage system and limit type set to %.

7) In case of 3-phase voltage system and limit type set to voltage.

8) In case of 3-phase voltage system and limit type set to %.

Test limits for IT earthing system:

Low limit(U12) ^{9,11)}	Min. voltage (U12) [Off, Custom, 0 V ... 499 V]
High limit(U12) ^{9,11)}	Max. voltage (U12) [Off, Custom, 0 V ... 499 V]
Low limit(U12) ¹⁰⁾	Min. voltage (U12) [Off, Custom, -20% ... 20%]
High limit(U12) ¹⁰⁾	Max. voltage (U12) [Off, Custom, -20% ... 20%]
Low limit(U1pe) ^{9,10)}	Min. voltage (U1pe) [Off, Custom, 0 V ... 499 V]
High limit(U1pe) ^{9,10)}	Max. voltage (U1pe) [Off, Custom, 0 V ... 499 V]
Low limit(U2pe) ^{9,10)}	Min. voltage (U2pe) [Off, Custom, 0 V ... 499 V]
High limit(U2pe) ^{9,10)}	Max. voltage (U2pe) [Off, Custom, 0 V ... 499 V]
Low limit(U13) ¹¹⁾	Min. voltage (U13) [Off, Custom, 0 V ... 499 V]
High limit(U13) ¹¹⁾	Max. voltage (U13) [Off, Custom, 0 V ... 499 V]
Low limit(U23) ¹¹⁾	Min. voltage (U23) [Off, Custom, 0 V ... 499 V]
High limit(U23) ¹¹⁾	Max. voltage (U23) [Off, Custom, 0 V ... 499 V]
Low limit (U12,U13,U23) ¹²⁾	Min. voltage (U12,U13,U23) [Off, Custom, -20% ... 20%]

High limit (U12,U13,U23)¹²⁾ Max. voltage (U12,U13,U23) [Off, Custom, -20% ... 20%]

- ⁹⁾ In case of 1-phase voltage system and limit type set to voltage.
- ¹⁰⁾ In case of 1-phase voltage system and limit type set to %.
- ¹¹⁾ In case of 3-phase voltage system and limit type set to voltage.
- ¹²⁾ In case of 3-phase voltage system and limit type set to %.

Connection diagrams

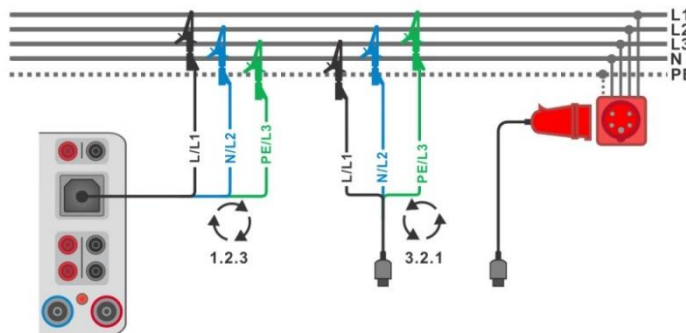

Figure 6.61: Connection of 3-wire test lead and optional adapter in three-phase system

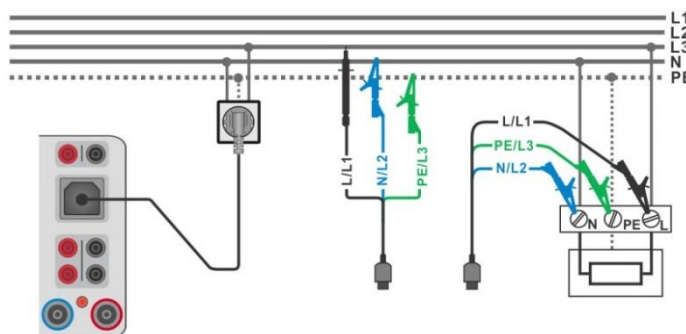

Figure 6.62: Connection of Plug test cable or 3-wire test lead in single-phase system

Measurement procedure

- ▶ Enter the **Voltage** function.
- ▶ Set test parameters / limits.
- ▶ Connect test cable to the instrument.
- ▶ Connect 3-wire test lead or Plug test cable to test object (see **Figure 6.61** and **Figure 6.62**).
- ▶ Start the continuous measurement.
- ▶ Stop the measurement.
- ▶ Save results (optional).

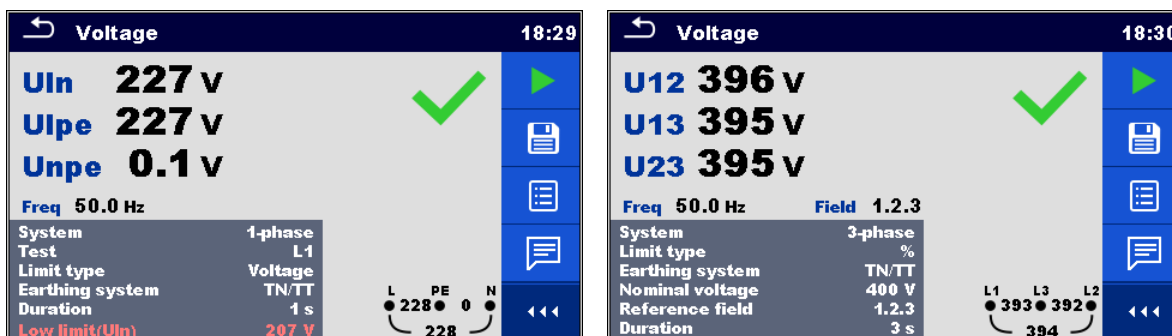

Figure 6.63: Voltage measurement results: single-phase (left) and three-phase system (right)

6.2.16 Z loop – Fault loop impedance and prospective fault current

Warning!

- MI 3325 checks voltage on TP1-PE terminal before running test and disables test in case the hazardous live voltage is detected. In this case, immediately remove supply from tested circuit, find, and eliminate problem before any other activity! See chapter 1.2 *Testing potential on TP1-PE terminal for installation tests* for more information.

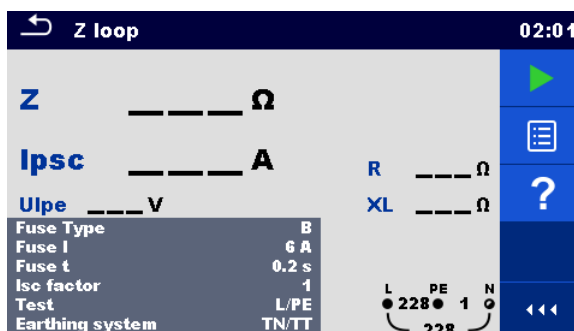

Figure 6.64: Z loop menu

Test results / sub-results

Z	Loop impedance
Ipsc	Prospective fault current
Ulpe	Voltage L-PE
R	Resistance of loop impedance
XL	Reactance of loop impedance

Prospective fault current I_{PSC} is calculated from measured impedance as follows:

$$I_{PSC} = \frac{U_N \times k_{SC}}{Z}$$

U_N Nominal U_{L-PE} voltage (see table below),

k_{SC} Correction factor (Isc factor) for I_{PSC} . See chapter 4.7.3 **Settings** for more information.

U_n	Input voltage range (L-PE)
110 V	$(93 \text{ V} \leq U_{L-PE} \leq 134 \text{ V})$
230 V	$(185 \text{ V} \leq U_{L-PE} \leq 266 \text{ V})$

Table 6.3: Relations between Input voltage – U_{L-PE} and nominal voltage – U_n used for calculation

Test parameters

Fuse Type	Selection of fuse type [Off, Custom, gG, NV, B, C, D, K, Z, L, U]
Fuse I	Rated current of selected fuse
Fuse t	Maximum breaking time of selected fuse
Isc factor	Correction factor Isc [Custom, 0.2 ... 3.0]
Test ¹⁾	Selection of test [-, L/PE, L1/PE, L2/PE, L3/PE]
Earthing system	[TN/TT, IT] Refer to chapter 4.7.3 Settings for more information.

¹⁾ With Plug test cable Z loop is measured in the same way regardless of the setting. The parameter is meant for documentation.

Refer to **Fuse tables guide** for detailed information on fuse data.

Test limits

la(Ipsc)	Minimum fault current for selected fuse or custom value
-----------------	---

Connection diagram

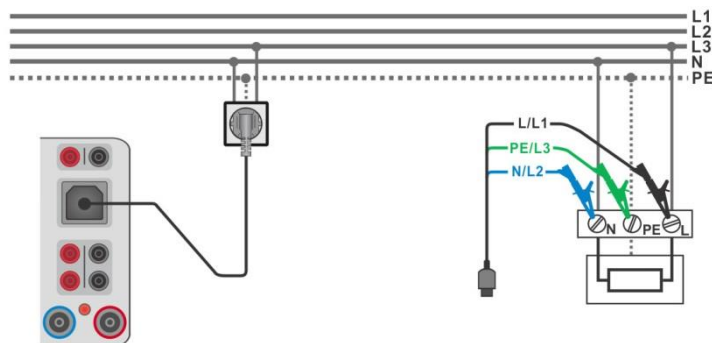

Figure 6.65: Connection of Plug test cable or 3-wire test lead

Measurement procedure

- › Enter the **Z loop** function.
- › Set test parameters / limits.
- › Connect test cable to the instrument.
- › Connect 3-wire test lead or Plug test cable to the object under test, see **Figure 6.65**.
- › Start the measurement.
- › Save results (optional).

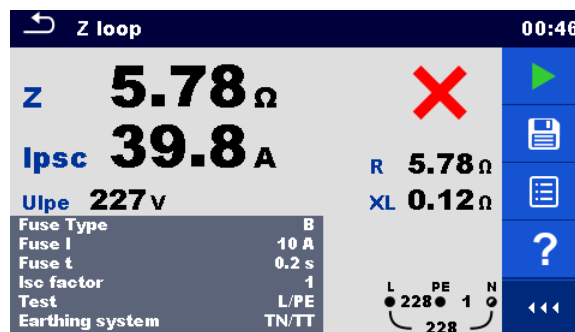
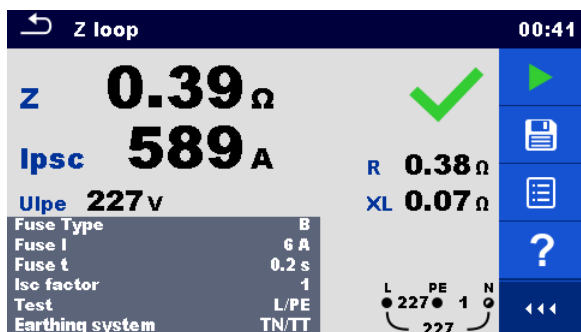
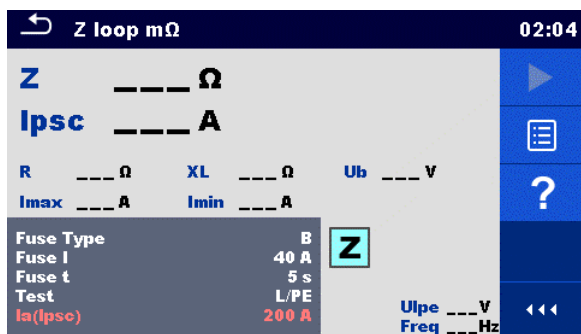
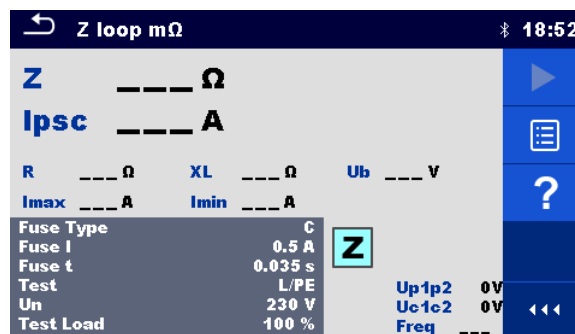

Figure 6.66: Examples of Loop impedance measurement result

6.2.17 Z loop mΩ – High precision fault loop impedance and prospective fault current



A 1143



MI 3143 or MI 3144

Figure 6.67: Z loop mΩ menu

Test results / sub-results

Z	Loop impedance
Ipsc	Standard prospective fault current
I_{max}	Maximal prospective fault current
I_{min}	Minimal prospective fault current
U_b	Contact voltage at maximal prospective fault current (contact voltage measured against Probe S if used)
R	Resistance of loop impedance
XL	Reactance of loop impedance

Voltage monitor using A 1143:

U_{lpe}	Voltage L-PE
Freq	Frequency

Voltage monitor using MI 3143 or MI 3144:

U_{p1p2}	Voltage P1-P2
U_{c1c2}	Voltage C1-C2
Freq	Frequency

Refer to **A 1143 – Euro Z 290 A**, **MI 3143 – Euro Z 440 V** and **MI 3144 – Euro Z 800 V Instruction manuals** for detailed information.

Test parameters

Fuse Type	Selection of fuse type [Off, Custom, gG, NV, B, C, D, K, Z, L, U]
Fuse I	Rated current of selected fuse
Fuse t	Maximum breaking time of selected fuse
Test¹⁾	Test [-, L/PE, L1/PE, L2/PE, L3/PE]
Test¹⁾	Test [-, L/PE, L1/PE, L2/PE, L3/PE]
Un²⁾	Nominal voltage [Custom, 110 V, 115 V, 127 V, 220 V, 230 V, 240 V, 290 V, 400 V, 460 V]
Tolerance²⁾	MI 3143 & MI 3144: Nominal voltage tolerance [6 %, 10 %]
Test Load²⁾	MI 3143: Test Load [33.3 %, 66.6 %, 100 %] MI 3144: Test Load [16.6 %, 33.3 %, 50.0 %, 66.6 %, 83.3 %, 100 %]
Average²⁾	MI 3143 & MI 3144: Average [Off, 2, 4, 6]
Isc factor²⁾	Isc factor [Custom, 0.2 ... 3]

¹⁾ The measurement doesn't depend on the setting. The parameter is meant for documentation.

²⁾ Parameter is available only if MI 3143 or MI 3144 Euro Z instrument is selected.

Refer to **Fuse tables guide** for detailed information on fuse data.

Test limits

I_a(Ipsc)	Minimum fault current for selected fuse or custom value
----------------------------	---

Connection diagram

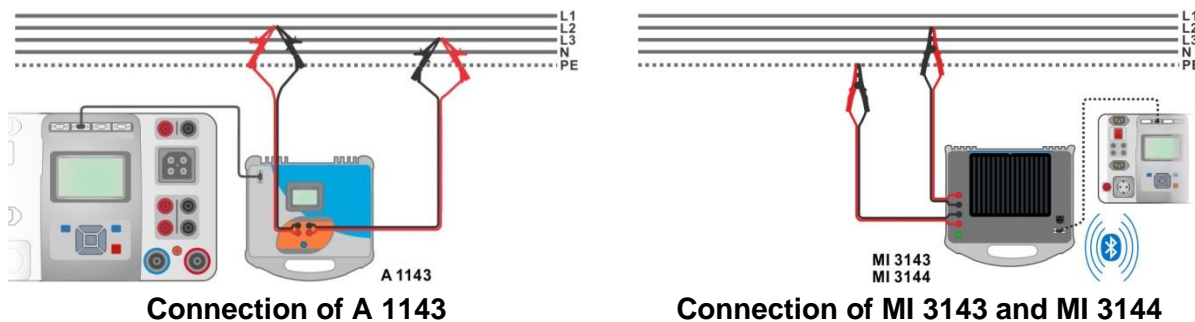

Connection of A 1143

Connection of MI 3143 and MI 3144

Figure 6.68: High precision loop impedance measurement

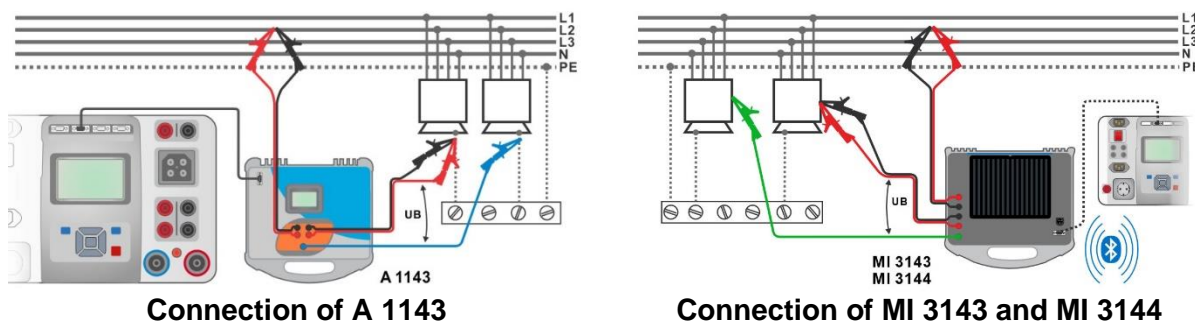



Connection of A 1143

Connection of MI 3143 and MI 3144

Figure 6.69: Contact voltage measurement

Measurement procedure

- ▶ Connect MI 3325 instrument with A 1143, MI 3143 or MI 3144 Euro Z adapter / instrument via serial RS232 or pair them using Bluetooth communication. See chapter **4.7.3 Settings**.
- ▶ Enter the **Z loop mΩ** function.
- ▶ Set test parameters / limits.
- ▶ Check Bluetooth communication active sign if MI 3143 or MI 3144 Euro Z instrument is connected to MI 3325 instrument via Bluetooth communication.
- ▶ Connect test leads to A 1143, MI 3143 or MI 3144 Euro Z adapter / instrument.
- ▶ Connect test leads to the object under test, see **Figure 6.68** and **Figure 6.69**.
- ▶ Start the measurement using  or  button.
- ▶ Save results (optional).

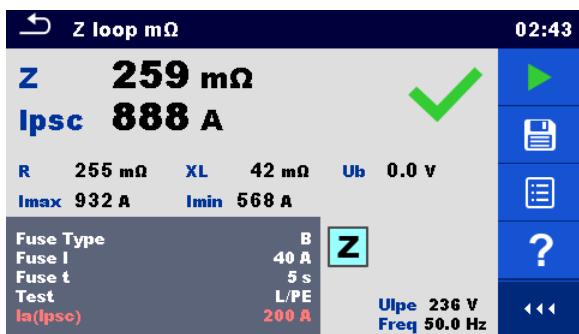

Result screen using A 1143



Result screen using MI 3143 or MI 3144

Figure 6.70: Examples of high precision Loop impedance measurement results

6.2.18 Zs rcd – Fault loop impedance and prospective fault current in system with RCD

Warning!

- MI 3325 checks voltage on TP1-PE terminal before running test and disables test in case the hazardous live voltage is detected. In this case, immediately remove supply from tested circuit, find, and eliminate problem before any other activity! See chapter 1.2 *Testing potential on TP1-PE terminal for installation tests* for more information.

Zs rcd measurement prevents trip-out of RCD protected systems.



Figure 6.71: Fault loop impedance and prospective fault current Zs rcd test menu

Test results / sub-results

Z	Loop impedance
Ipsc	Prospective fault current
Ulpe	Voltage L-PE
Uc¹⁾	Contact voltage; calculation: $U_C = Z \times I_{\Delta N}$
R	Resistance of loop impedance
XL	Reactance of loop impedance

¹⁾ Result is presented only if Protection is set to TT rcd.

Prospective fault current I_{PSC} is calculated from measured impedance as follows:

$$I_{PSC} = \frac{U_N \times k_{SC}}{Z}$$

U_N Nominal U_{L-PE} voltage (see table below),

k_{SC} Correction factor (Isc factor) for I_{PSC} . See chapter 4.7.3 **Settings** for more information.

U_n	Input voltage range (L-PE)
110 V	(93 V ≤ U_{L-PE} ≤ 134 V)
230 V	(185 V ≤ U_{L-PE} ≤ 266 V)

Table 6.4: Relation between Input voltage – U_{L-PE} and nominal voltage – U_n used for calculation

Test parameters

Protection	Protection type [TN, TT rcd]
Fuse Type¹⁾	Selection of fuse type [Off, Custom, gG, NV, B, C, D, K, Z, L, U]
Fuse I¹⁾	Rated current of selected fuse

Fuse t¹⁾	Maximum breaking time of selected fuse
Isc factor	Correction factor Isc [Custom, 0.2 ... 3.0]
Test³⁾	Selection of test [-, L-PE, L1-PE, L2-PE, L3-PE]
I ΔN²⁾	Rated RCD residual current sensitivity [10 mA, 15 mA, 30 mA, 100 mA, 300 mA, 500 mA, 1000 mA]
RCD type²⁾	RCD type [AC, A, F, B, B+]
Selectivity²⁾	Characteristic [G, S]
I test	Test current [Standard, Low]

- 1) Parameter or limit is considered if Protection is set to TN.
- 2) Parameter or limit is considered if Protection is set to TT rcd.
- 3) With Plug test cable or 3-wire test lead Zs rcd is measured in the same way regardless of the setting. The parameter is meant for documentation.

Refer to **Fuse tables guide** for detailed information on fuse data.

Test limits

Ia(Ipsc)¹⁾	Minimum fault current for selected ¹⁾ fuse or custom value
Limit Uc	Contact voltage limit [Custom, 12 V, 25 V, 50 V]

- 1) Parameter or limit is considered if Protection is set to TN.
- 2) Parameter or limit is considered if Protection is set to TT rcd.

Connection diagram

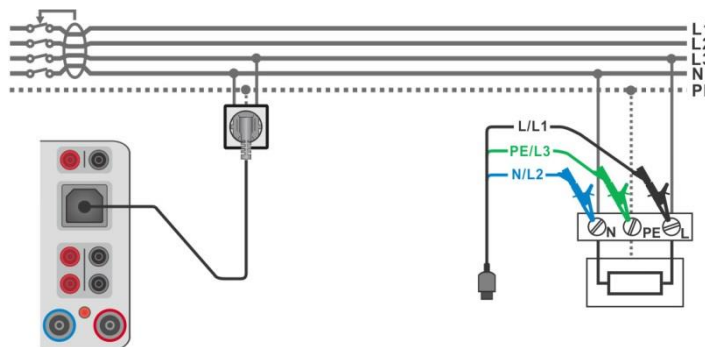

Figure 6.72: Connection of Plug test cable or 3-wire test lead

Measurement procedure

- ▶ Enter the **Zs rcd** function.
- ▶ Set test parameters / limits.
- ▶ Connect test cable to the instrument.
- ▶ Connect 3-wire test lead or Plug test cable to the object under test, see **Figure 6.72**.
- ▶ Start the measurement.
- ▶ Save results (optional).

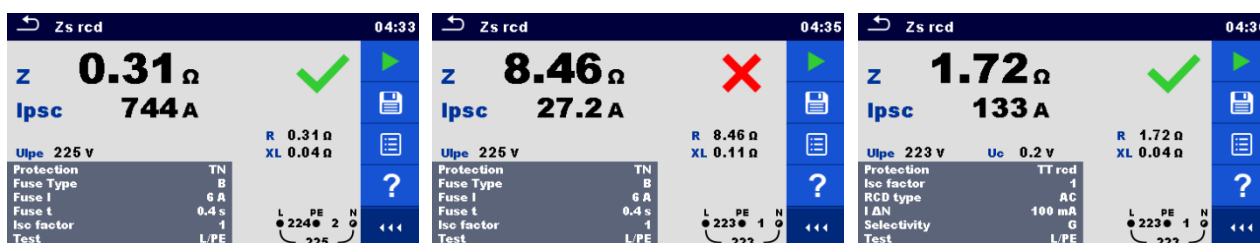

Figure 6.73: Examples of Zs rcd measurement results

6.2.19 Z line – Line impedance and prospective short-circuit current

Note!

- MI 3325 checks voltage on TP1-PE terminal before running test and warning message is presented in case the hazardous live voltage is detected. It is recommended to remove supply from tested circuit, find, and eliminate problem before any other activity! See chapter 1.2 *Testing potential on TP1-PE terminal for installation tests* for more information.

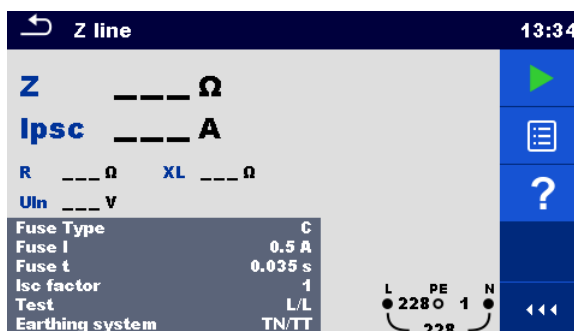

Figure 6.74: Z line measurement menu

Test results / sub-results

Z	Line impedance
Ipsc	Prospective short-circuit current
Uln	Voltage measured between L and N test terminals
R	Resistance of line impedance
XL	Reactance of line impedance
I_{max3p}	Maximal three-phases prospective short-circuit current
I_{min3p}	Minimal three-phases prospective short-circuit current
I_{max2p}	Maximal two-phases prospective short-circuit current
I_{min2p}	Minimal two-phases prospective short-circuit current
I_{max}	Maximal single-phase prospective short-circuit current
I_{min}	Minimal single-phase prospective short-circuit current

Prospective short circuit current I_{PSC} is calculated as follows:

$$I_{PSC} = \frac{U_N \times k_{SC}}{Z}$$

U_N Nominal U_{L-N} or U_{L-L} voltage (see table below),

k_{SC} Correction factor (Isc factor) for I_{PSC} . See chapter 4.7.3 **Settings** for more information.

U_n	Input voltage range (L-N or L-L)
110 V	$(93 \text{ V} \leq U_{L-N} \leq 134 \text{ V})$
230 V	$(185 \text{ V} \leq U_{L-N} \leq 266 \text{ V})$
400 V	$(321 \text{ V} \leq U_{L-L} \leq 485 \text{ V})$

Table 6.5: Relation between Input voltage – $U_{L-N(L)}$ and nominal voltage – U_n used for calculation

The prospective short-circuit currents I_{Min} , I_{Min2p} , I_{Min3p} and I_{Max} , I_{Max2p} , I_{Max3p} are calculated as follows:

$I_{Min} = \frac{C_{min} U_{N(L-N)}}{Z_{(L-N)hot}}$	where	$Z_{(L-N)hot} = \sqrt{(1.5 \times R_{(L-N)})^2 + X_{(L-N)}^2}$ $C_{min} = \begin{cases} 0.95; & U_{N(L-N)} = 230 V \pm 10 \% \\ 1.00; & otherwise \end{cases}$
$I_{Max} = \frac{C_{max} U_{N(L-N)}}{Z_{(L-N)}}$	where	$Z_{(L-N)} = \sqrt{R_{(L-N)}^2 + X_{(L-N)}^2}$ $C_{max} = \begin{cases} 1.05; & U_{N(L-N)} = 230 V \pm 10 \% \\ 1.10; & otherwise \end{cases}$
$I_{Min2p} = \frac{C_{min} U_{N(L-L)}}{Z_{(L-L)hot}}$	where	$Z_{(L-L)hot} = \sqrt{(1.5 \times R_{(L-L)})^2 + X_{(L-L)}^2}$ $C_{min} = \begin{cases} 0.95; & U_{N(L-L)} = 400 V \pm 10 \% \\ 1.00; & otherwise \end{cases}$
$I_{Max2p} = \frac{C_{max} U_{N(L-L)}}{Z_{(L-L)}}$	where	$Z_{(L-L)} = \sqrt{R_{(L-L)}^2 + X_{(L-L)}^2}$ $C_{max} = \begin{cases} 1.05; & U_{N(L-L)} = 400 V \pm 10 \% \\ 1.10; & otherwise \end{cases}$
$I_{Min3p} = \frac{C_{min} \times U_{N(L-L)}}{\sqrt{3}} \frac{2}{Z_{(L-L)hot}}$	where	$Z_{(L-L)hot} = \sqrt{(1.5 \times R_{(L-L)})^2 + X_{(L-L)}^2}$ $C_{min} = \begin{cases} 0.95; & U_{N(L-L)} = 400 V \pm 10 \% \\ 1.00; & otherwise \end{cases}$
$I_{Max3p} = \frac{C_{max} \times U_{N(L-L)}}{\sqrt{3}} \frac{2}{Z_{(L-L)}}$	where	$Z_{(L-L)} = \sqrt{R_{(L-L)}^2 + X_{(L-L)}^2}$ $C_{max} = \begin{cases} 1.05; & U_{N(L-L)} = 400 V \pm 10 \% \\ 1.10; & otherwise \end{cases}$

Test parameters

Fuse Type	Selection of fuse type [Off, Custom, gG, NV, B, C, D, K, Z, L, U]
Fuse I	Rated current of selected fuse
Fuse t	Maximum breaking time of selected fuse
Isc factor	Correction factor Isc [Custom, 0.2 ... 3.0]
Test¹⁾	Test [-, L/N, L/L, L1/N, L2/N, L3/N, L1/L2, L1/L3, L2/L3]
Earthing system	[TN/TT, IT] Refer to chapter 4.7.3 Settings for more information.

¹⁾ With Plug test cable or 3-wire test lead Z line is measured in the same way regardless of the setting. The parameter is meant for documentation.

Refer to **Fuse tables guide** for detailed information on fuse data.

Test limits

Ia(Ipsc)	Minimum short-circuit current for selected fuse or custom value
-----------------	---

Connection diagram

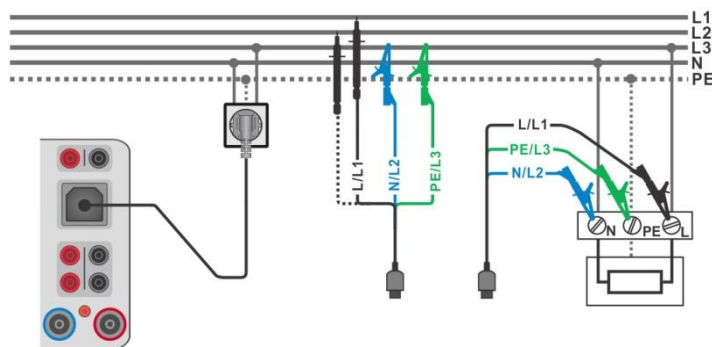

Figure 6.75: Phase-neutral or phase-phase line impedance measurement – connection of Plug test cable or 3-wire test lead

Measurement procedure

- › Enter the **Z line** function.
- › Set test parameters / limits.
- › Connect test cable to the instrument.
- › Connect 3-wire test lead or Plug test cable to the object under test, see **Figure 6.75**.
- › Start the measurement.
- › Save results (optional).

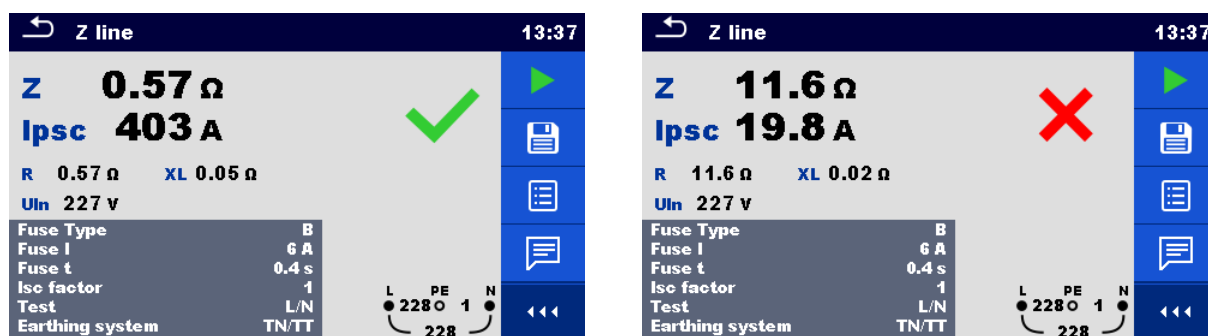

Figure 6.76: Examples of Line impedance measurement result

6.2.20 Z line mΩ – High precision line impedance and prospective short-circuit current



Figure 6.77: Z line mΩ test menu

Test results / sub-results

Z	Line impedance
Ipsc	Standard prospective short-circuit current
I_{max}	Maximal prospective short-circuit current
I_{min}	Minimal prospective short-circuit current
I_{max2p}	Maximal two-phases prospective short-circuit current
I_{min2p}	Minimal two-phases prospective short-circuit current
I_{max3p}	Maximal three-phases prospective short-circuit current
I_{min3p}	Minimal three-phases prospective short-circuit current
R	Resistance of line impedance
XL	Reactance of line impedance

Voltage monitor using A 1143:

U_{ln}	Voltage L-N or L-L
Freq	Frequency

Voltage monitor using MI 3143 or MI 3144:

U_{p1p2}	Voltage P1-P2
U_{c1c2}	Voltage C1-C2
Freq	Frequency

Refer to **A 1143 – Euro Z 290 A**, **MI 3143 – Euro Z 440 V** and **MI 3144 – Euro Z 800 V Instruction manuals** for detailed information.

Test parameters

Fuse Type	Selection of fuse type [Off, Custom, gG, NV, B, C, D, K, Z, L, U]
Fuse I	Rated current of selected fuse
Fuse t	Maximum breaking time of selected fuse
Test¹⁾	Test [-, L/N, L/L, L1/N, L2/N, L3/N, L1/L2, L1/L3, L2/L3]
U_n²⁾	Test=[-, L/N, L1/N, L2/N, L3/N]: Nominal voltage [Custom, 110 V, 115 V, 127 V, 220 V, 230 V, 240 V, 290 V, 400 V, 460 V] Test=[L/L, L1/L2, L1/L3, L2/L3]: Nominal voltage [Custom, 190 V, 200 V, 220 V, 380 V, 400 V, 415 V, 500 V, 690 V, 800 V]
Tolerance²⁾	MI 3143 & MI 3144: Nominal voltage tolerance [6 %, 10 %]
Test Load²⁾	MI 3143: Test Load [33.3 %, 66.6 %, 100 %] MI 3144: Test Load [16.6 %, 33.3 %, 50.0 %, 66.6 %, 83.3 %, 100 %]
Average²⁾	MI 3143 & MI 3144: Average [Off, 2, 4, 6]
Isc factor²⁾	Isc factor [Custom, 0.20 ... 3.00]

¹⁾ The measuring results (for phase – neutral or phase – phase line) are set according to the setting. The parameter is meant for documentation.

²⁾ Parameter is available only if MI 3143 or MI 3144 Euro Z instrument is selected.

Refer to **Fuse tables guide** for detailed information on fuse data.

Test limits

I_a(Ipsc)	Minimum short circuit current for selected fuse or custom value
----------------------------	---

Connection diagram

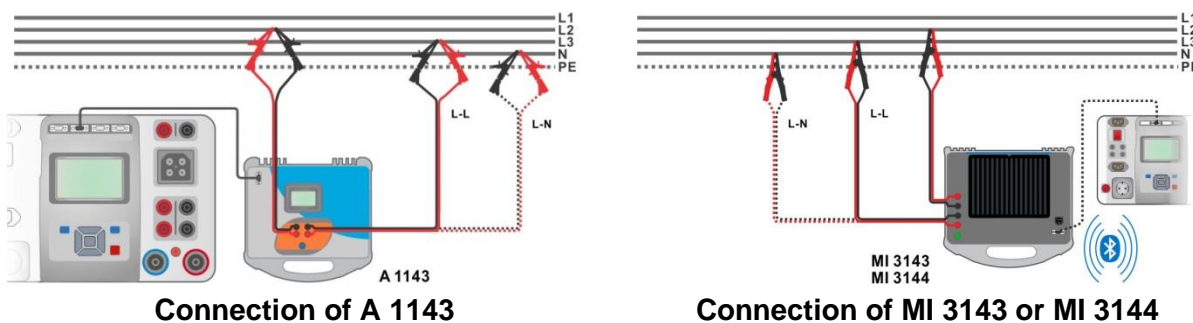

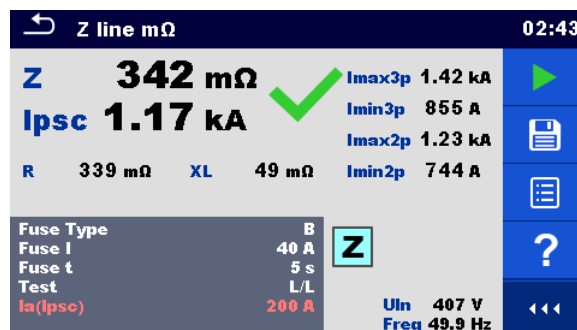
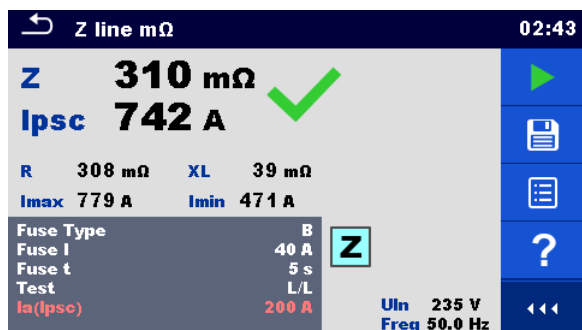

Figure 6.78: Phase-neutral or phase-phase high precision Line impedance measurement

Measurement procedure

- ▶ Connect MI 3325 instrument with A 1143, MI 3143 or MI 3144 Euro Z adapter / instrument via serial RS232 or pair them using Bluetooth communication. See chapter 4.7.3 Settings.
- ▶ Enter the **Z line mΩ** function.
- ▶ Set test parameters / limits.
- ▶ Check Bluetooth communication active sign if MI 3143 or MI 3144 Euro Z instrument is connected to MI 3325 instrument via Bluetooth communication.
- ▶ Connect test leads to A 1143, MI 3143 or MI 3144 Euro Z adapter / instrument.
- ▶ Connect test leads to the object under test, see Figure 6.78.

- ▶ Start the measurement using  or  button.
- ▶ Save results (optional).



Result screens using A 1143

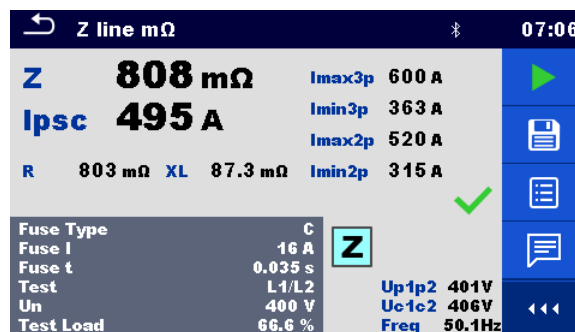

Result screens using MI 3143 or MI 3144

Figure 6.79: Examples of high precision Line impedance measurement result

6.2.21 High Current (MI 3143 and MI 3144)

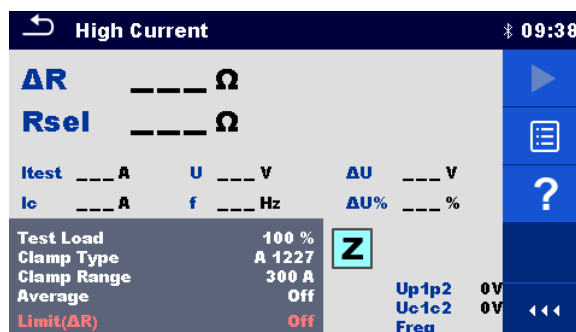

Figure 6.80: High Current menu

Test results / sub-results

ΔR	Resistance
Rsel¹⁾	Resistance (calculated from Clamp current)
Itest	Test current
Ic¹⁾	Clamp current
U	Voltage
f	Frequency
ΔU	Voltage dip
ΔU%	Voltage dip in percentage [$\Delta U (\%) = (\Delta U / U_{\text{unloaded}}) \times 100 \%$]

¹⁾ Measurement with current clamps is supported by **MI 3144 – Euro Z 800 V** instrument only.

Voltage monitor:

Up1p2	Voltage P1-P2
Uc1c2	Voltage C1-C2
Freq	Frequency

Refer to **MI 3143 – Euro Z 440 V** and **MI 3144 – Euro Z 800 V Instruction manuals** for detailed information.

Test parameters

Test Load	MI 3143: Test load [33.3 %, 66.6 %, 100 %] MI 3144: Test load [16.6 %, 33.3 %, 50.0 %, 66.6 %, 83.3 %, 100 %]
Clamp Type¹⁾	Clamp type [A 1227, A 1281, A 1609]
Clamp Range¹⁾	Range @ A 1227, A 1609 [30 A, 300 A, 3000 A] Range @ A 1281 [0.5 A, 5 A, 100 A, 1000 A]
Average	Average [Off, 2, 4, 6]

¹⁾ Measurement with current clamps is supported by **MI 3144 – Euro Z 800 V** instrument only.

Test limits

Limit (ΔR)	Limit [Off, Custom, 0.01 Ω ... 19 Ω]
-------------------	---

Connection diagram

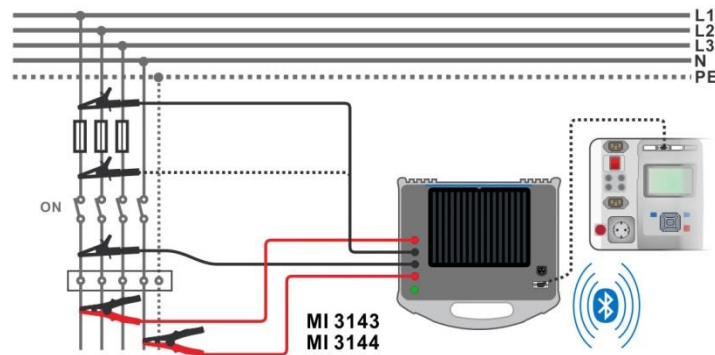



Figure 6.81: High Current resistance measurement

Measurement procedure

- › Connect MI 3325 instrument with MI 3143 or MI 3144 Euro Z instrument via serial RS232 or pair them using Bluetooth communication. See chapter **4.7.3 Settings**.
- › Enter the **High Current** function.
- › Set test parameters / limits.
- › Check Bluetooth communication active sign if MI 3143 or MI 3144 Euro Z instrument is connected to MI 3325 instrument via Bluetooth communication.
- › Connect test leads to MI 3143 or MI 3144 Euro Z instrument.
- › Connect test leads to the object under test, see **Figure 6.81**.
Refer to **MI 3143 – Euro Z 440 V** or **MI 3144 – Euro Z 800 V Instruction manual** for detailed information.

- › Start the measurement using  or  button.
- › Save results (optional).

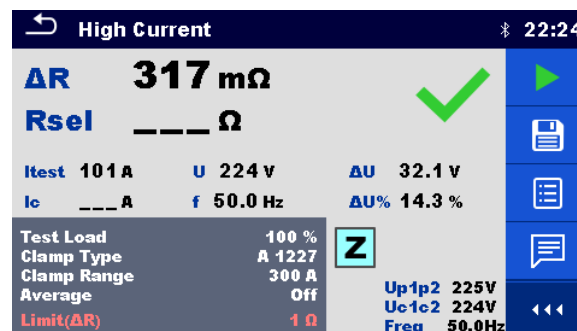

Figure 6.82: Example of High Current measurement result

6.2.22 Z auto - Auto test sequence for fast line and loop testing

Warning!

- › MI 3325 checks voltage on TP1-PE terminal before running test and disables test in case the hazardous live voltage is detected. In this case, immediately remove supply from tested circuit, find, and eliminate problem before any other activity! See chapter **1.2 Testing potential on TP1-PE terminal for installation tests** for more information.

Tests / measurements implemented in Z auto test sequence are:

Voltage

Voltage Drop**Z line****Zs rcd****Uc**

Figure 6.83: Z auto test menu

Test results / sub-results

Uln	Voltage between phase and neutral conductors
ΔU	Voltage drop
Z (LN)	Line impedance
Z (LPE)	Loop impedance
Zref	Reference line impedance
Ipsc (LN)	Prospective short-circuit current
Ipsc (LPE)	Prospective fault current
Uc	Contact voltage

Test parameters

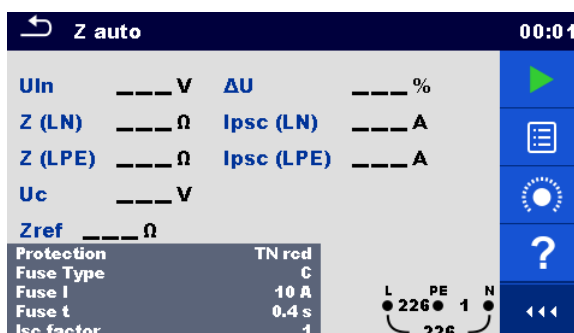
Protection	Protection type [TN, TNrcd, TTrcd]
Fuse type	Selection of fuse type [Off, Custom, gG, NV, B, C, D, K, Z, L, U]
Fuse I	Rated current of selected fuse
Fuse t	Maximum breaking time of selected fuse
I (ΔU)¹⁾	Rated current for ΔU measurement (custom value)
Isc factor	Correction factor Isc [Custom, 0.2 ... 3.0]
RCD Type	RCD type [AC, A, F, B, B+]
I ΔN	Rated RCD residual current sensitivity [10 mA, 15 mA, 30 mA, 100 mA, 300 mA, 500 mA, 1000 mA]
Selectivity	RCD Characteristic [G, S]
Phase²⁾	Selection of test [-, L1, L2, L3]
I test	Test current [Standard, Low]

¹⁾ Applicable if Fuse type is set to Off or Custom.

²⁾ With Plug test cable or 3-wire test lead tests are measured in the same way regardless of the setting. The parameter is meant for documentation.

Refer to **Fuse tables guide** for detailed information on fuse data.

Test limits

Limit(ΔU)	Maximum voltage drop [Off, Custom, 3.0 % ... 9.0 %]
Ia(Ipsc(LN), Ipsc(LPE))³⁾	Minimum short circuit current for selected fuse or custom value
Limit Uc	Conventional touch voltage limit [Custom, 12 V, 25 V, 50 V]

³⁾ Ipsc (LPE) is considered if Protection is set to TNrcd. Ipsc(LN) is always considered.

Connection diagram

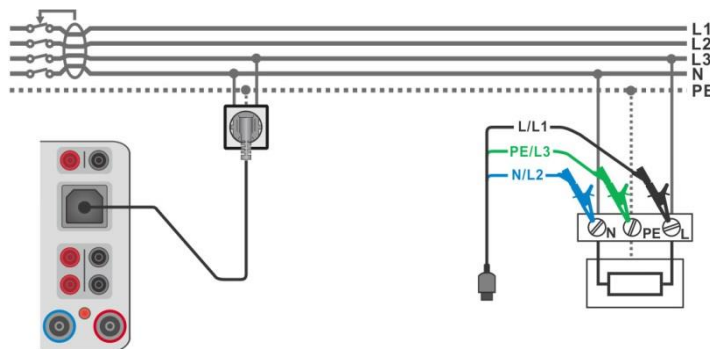

Figure 6.84: Z auto measurement connection

Measurement procedure

- › Enter the **Z auto** function.
- › Set test parameters / limits.
- › Measure the impedance Z_{ref} at origin (optional), see chapter **6.2.23 Voltage Drop**.
- › Connect test cable to the instrument.
- › Connect 3-wire test lead or Plug test cable to the object under test, see **Figure 6.84**.
- › Start the Auto test.
- › Save results (optional).

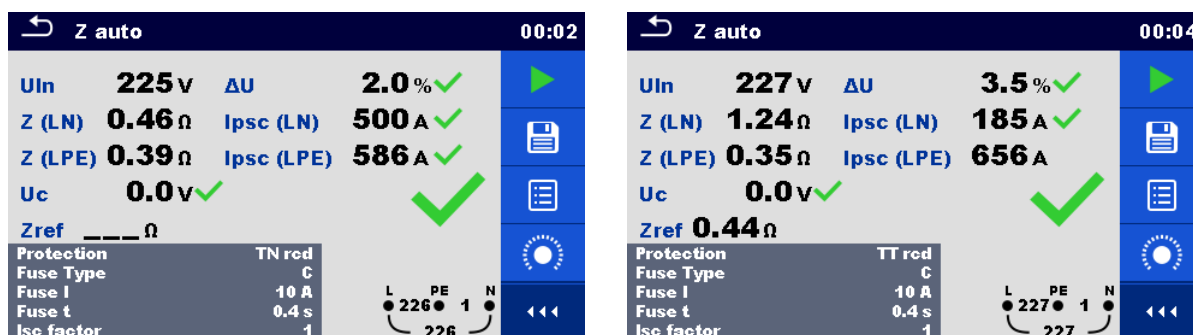

Figure 6.85: Examples of Z auto measurement results

6.2.23 Voltage Drop

Note!

- › MI 3325 checks voltage on Zline-PE terminal before running test and warning message is presented in case the hazardous live voltage is detected. It is recommended to remove supply from tested circuit, find, and eliminate problem before any other activity! See chapter **1.2 Testing potential on TP1-PE terminal for installation tests** for more information.

The voltage drop is calculated based on the difference of line impedance at connection points (sockets) and the line impedance at the reference point (usually the impedance at the switchboard).

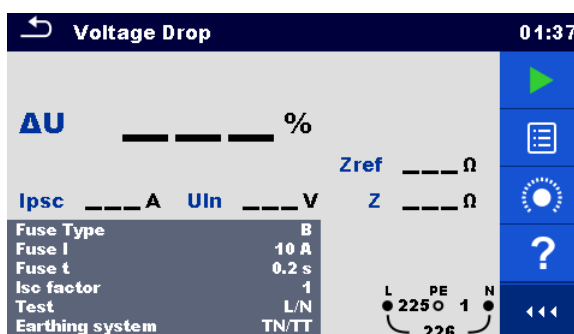

Figure 6.86: Voltage drop menu

Test results / sub-results

ΔU	Voltage drop
Ipsc	Prospective short-circuit current
Uln	Voltage L-N
Zref	Reference line impedance
Z	Line impedance

Voltage drop ΔU [%] is calculated as follows:

$$\Delta U [\%] = \frac{(Z - Z_{REF}) \cdot I_N}{U_N} \cdot 100$$

where:

Zref	Impedance at reference point (at origin)
Z	Impedance at test point
U_N	Nominal U _{L-N} or U _{L-L} voltage (see table below)
I_N	Rated current of selected fuse (Fuse I)

U_N	Input voltage range (L-N or L-L)
110 V	(93 V ≤ U _{L-N} ≤ 134 V)
230 V	(185 V ≤ U _{L-N} ≤ 266 V)
400 V	(321 V ≤ U _{L-L} ≤ 485 V)

Table 6.6: Relations between Input voltage – U_{L-N(L)} and nominal voltage – U_n used for calculation

Test parameters

Fuse Type	Selection of fuse type [Off, Custom, gG, NV, B, C, D, K, Z, L, U]
Fuse I	Rated current of selected fuse
Fuse t	Maximum breaking time of selected fuse
I (ΔU)¹⁾	Rated current for ΔU measurement (custom value)
Isc factor	Correction factor Isc [Custom, 0.2 ... 3.0]
Test²⁾	Test [-, L/N, L/L, L1/N, L2/N, L3/N, L1/L2, L1/L3, L2/L3]
Earthing system	[TN/TT, IT] Refer to chapter 4.7.3 Settings for more information.

¹⁾ Applicable if Fuse type is set to Off or Custom

²⁾ With Plug test cable Voltage drop is measured in the same way regardless of the setting. The parameter is meant for documentation.

Refer to **Fuse tables guide** for detailed information on fuse data.

Test limits

Limit(ΔU) Maximum voltage drop [Off, Custom, 3.0 % ... 9.0 %]

Connection diagram

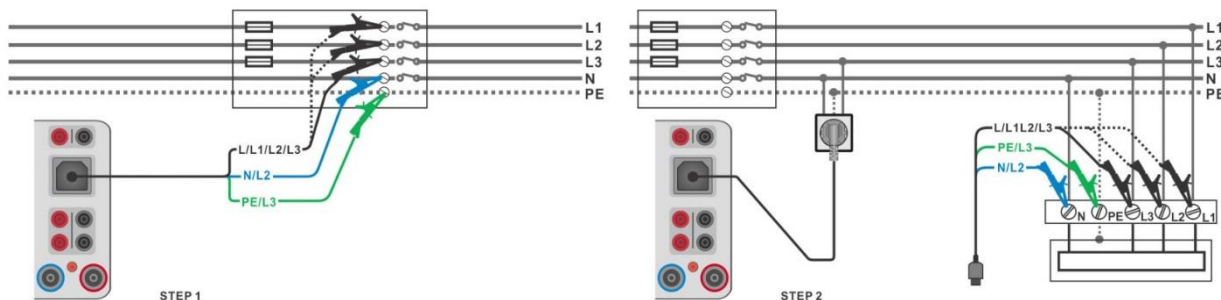



Figure 6.87: Zref (STEP1) and Voltage drop (STEP2) measurement – connection of Plug test cable or 3-wire test lead

Measurement procedure

STEP 1: Measuring the impedance Zref at origin

- › Enter the **Voltage Drop** function.
- › Set test parameters / limits.
- › Connect test cable to the instrument.
- › Connect 3-wire test lead to the origin of electrical installation, see **Figure 6.87**.
- › Touch the  icon to execute Zref measurement.

STEP 2: Measuring the Voltage drop

- › Enter the **Voltage Drop** function.
- › Set test parameters / limits.
- › Connect test cable to the instrument.
- › Connect 3-wire test lead or Plug test cable to the tested points, see **Figure 6.87**.
- › Start the measurement.
- › Save results (optional).

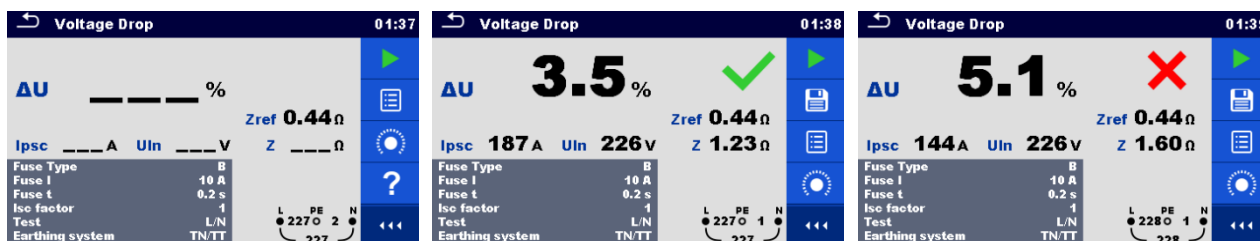

Figure 6.88: Examples of measurement result: Zref (STEP 1, left figure) and Voltage drop (STEP 2)

6.2.24 U touch – Touch voltage (MI 3143 and MI 3144)

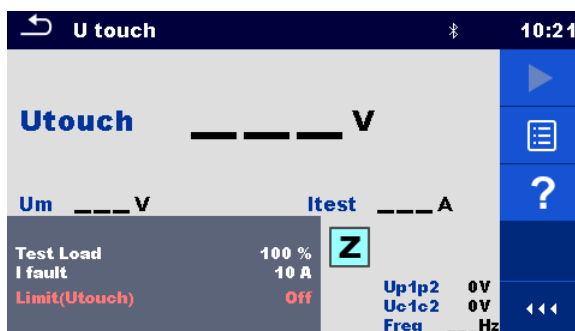

Figure 6.89: Touch voltage menu

Test results / sub-results

Utouch	Calculated touch voltage
Um	Measured voltage drop
Itest	Test current

Voltage monitor:

Up1p2	Voltage P1-P2
Uc1c2	Voltage C1-C2
Freq	Frequency

Refer to **MI 3143 Euro Z 440 V** and **MI 3144 Euro Z 800 V Instruction manuals** for detailed information.

Test parameters

Test Load	MI 3143: Test load [33.3 %, 66.6 %, 100 %] MI 3144: Test load [16.6 %, 33.3 %, 50.0 %, 66.6 %, 83.3 %, 100 %]
I fault	Fault current [Custom, 10 A ... 200 kA]

Test limits

Limit(Utouch)	Limit [Off, Custom, 25 V, 50 V]
----------------------	--

Connection diagram

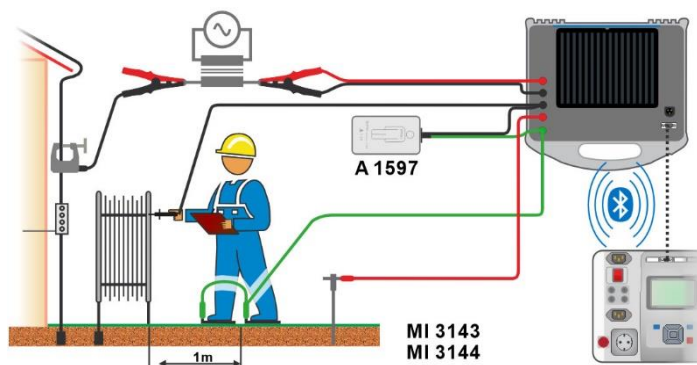



Figure 6.90: Touch voltage measurement – Connection of MI 3143 or MI 3144

Measurement procedure

- › Connect MI 3325 instrument with MI 3143 or MI 3144 Euro Z instrument via serial RS232 or pair them using Bluetooth communication. See chapter **4.7.3 Settings**.
- › Enter the **U touch** function.
- › Set test parameters / limits.
- › Check Bluetooth communication active sign if MI 3143 or MI 3144 Euro Z instrument is connected to MI 3325 instrument via Bluetooth communication.
- › Connect test leads and A 1597 adapter to MI 3143 or MI 3144 Euro Z instrument.
- › Connect test leads to the object under test.
Refer to **MI 3143 Euro Z 440 V** or **MI 3144 Euro Z 800 V Instruction manual** for detailed information.

- › Start the measurement using  or  button.
- › Save results (optional).

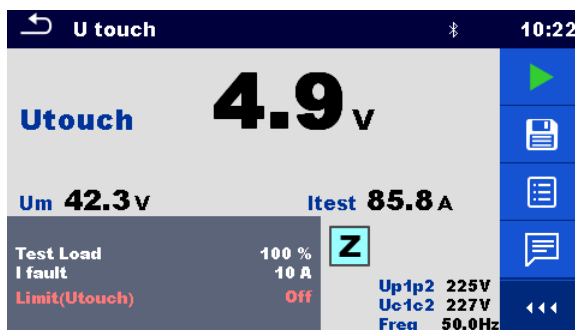

Figure 6.91: Example of Touch voltage measurement result

6.2.25 R line mΩ – DC resistance measurement (MI 3144)

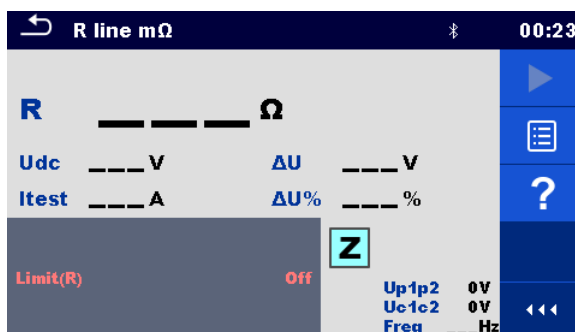

Figure 6.92: R line mΩ menu

Test results / sub-results

R	Line resistance
Itest	Test current
Udc	Voltage
ΔU	Voltage drop
ΔU%	Voltage drop in percentage

Voltage monitor:

Up1p2	Voltage P1-P2
Uc1c2	Voltage C1-C2
Freq	Frequency

Refer to *MI 3144 Euro Z 800 V Instruction manual* for detailed information.

Test limit



Limit (R)	Limit [Off, Custom, 0.01 Ω ... 19 Ω]
------------------	---

Connection diagram

Refer to *MI 3144 – Euro Z 800 V Instruction manual* for detailed information.

Measurement procedure

- Connect MI 3325 instrument with MI 3144 Euro Z 800 V instrument via serial RS232 or pair them using Bluetooth communication. See chapter **4.7.3 Settings**.
- Enter the **R line m Ω** function.
- Set test parameters / limits.
- Check Bluetooth communication active sign if MI 3144 Euro Z 800 V instrument is connected to MI 3325 instrument via Bluetooth communication.
- Connect test leads to MI 3144 Euro Z 800 V instrument.
- Connect test leads to the object under test.
Refer to *MI 3144 Euro Z 800 V Instruction manual* for detailed information.

- Start the measurement using  or  button.
- Save results (optional).

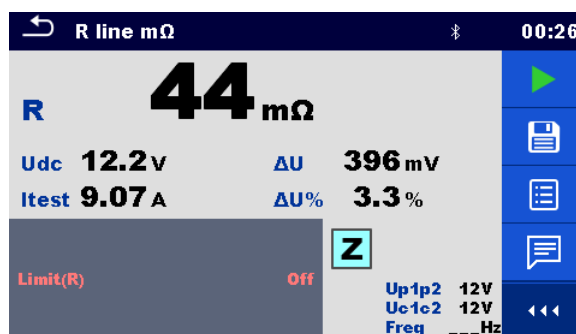

Figure 6.93: Example of R line m Ω measurement result

6.2.26 ELR Current Injection Test (MI 3144)

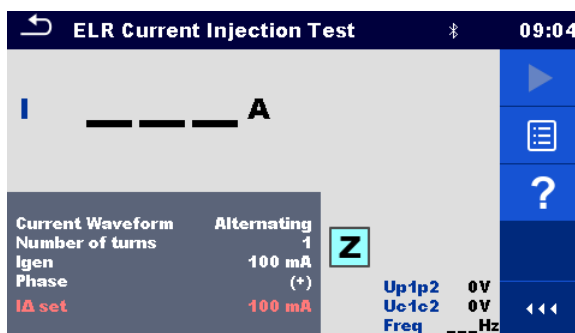

Figure 6.94: ELR Current Injection Test menu

Test results / sub-results

I	Current
---	---------

Voltage monitor:

Up1p2	Voltage P1-P2
Uc1c2	Voltage C1-C2
Freq	Frequency

Refer to *MI 3144 Euro Z 800 V Instruction manual* for detailed information.

Test parameters

Current Waveform	Current waveform [Alternating, Pulsating, DC]
Number of turns	Number of turns [1 ... 10]
I gen	Current [3 mA, 5 mA, 6 mA, 10 mA, 15 mA, 30 mA, 50 mA, 100 mA, 150 mA, 250 mA, 300 mA, 500 mA]
Phase	Phase [(+), (-)]

Test limit

IA set	Current limit for selected generated current and number of turns
--------	--

Connection diagram

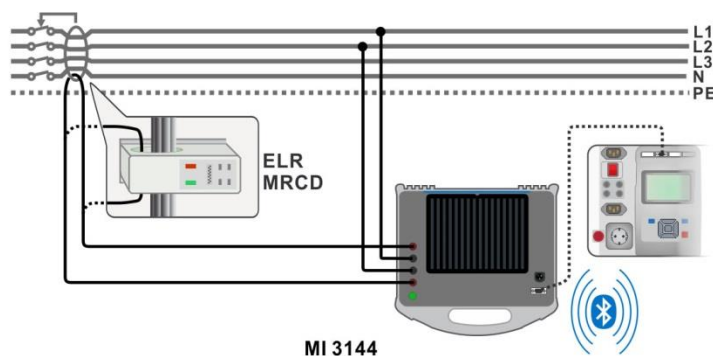







Figure 6.95: ELR Current Injection Test / Combination Time Test connection

Refer to *MI 3144 Euro Z 800 V Instruction manual* for detailed information.

Measurement procedure

- › Connect MI 3325 instrument with MI 3144 Euro Z 800 V instrument via serial RS232 or pair them using Bluetooth communication. See chapter **4.7.3 Settings**.
- › Enter the **ELR Current Injection Test** function.
- › Set test parameters / limits.
- › Check Bluetooth communication active sign if MI 3144 Euro Z 800 V instrument is connected to MI 3325 instrument via Bluetooth communication.
- › Connect test leads to MI 3144 Euro Z 800 V instrument.
- › Connect test leads to the object under test. See **Figure 6.95**. Refer to **MI 3144 Euro Z 800 V Instruction manual** for detailed information.

- › Start the measurement using  or  button.
- › Use  to select PASS / FAIL / NO STATUS indication.
- › Press  or the  key to confirm selection and complete the measurement.
- › Save results (optional).

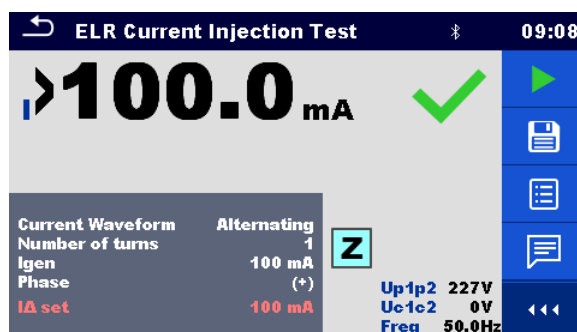

Figure 6.96: Example of ELR Current Injection Test result

6.2.27 ELR Combination Time Test (MI 3144)

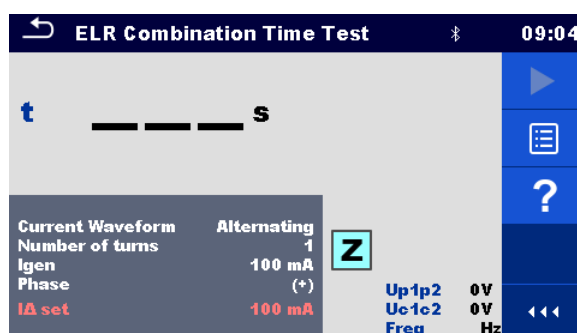

Figure 6.97: ELR Combination Time Test menu

Test results / sub-results

t	Time
---	------

Voltage monitor:

Up1p2	Voltage P1-P2
--------------	---------------

Uc1c2	Voltage C1-C2
--------------	---------------

Freq	Frequency
-------------	-----------

Refer to **MI 3144 Euro Z 800 V Instruction manual** for detailed information.

Test parameters

Current Waveform	Current waveform [Alternating, Pulsating, DC]
Number of turns	Number of turns [1 ... 10]
I gen	Current [3 mA, 5 mA, 6 mA, 10 mA, 15 mA, 30 mA, 50 mA, 100 mA, 150 mA, 250 mA, 300 mA, 500 mA]
Phase	Phase [(+), (-)]
Test duration	Duration [0.3 s, 0.5 s, 1 s, 2 s, 5 s, 10 s, 20 s]

Test limit

IΔ set	Current limit for selected generated current and number of turns
---------------	--





Connection diagram

See **Figure 6.95: ELR Current Injection Test / Combination Time Test connection**

Refer to **MI 3144 Euro Z 800 V Instruction manual** for detailed information.

Measurement procedure

- Connect MI 3325 instrument with MI 3144 Euro Z 800 V instrument via serial RS232 or pair them using Bluetooth communication. See chapter **4.7.3 Settings**.
- Enter the **ELR Combination Time Test** function.
- Set test parameters / limits.
- Check Bluetooth communication active sign if MI 3144 Euro Z 800 V instrument is connected to MI 3325 instrument via Bluetooth communication.
- Connect test leads to MI 3144 Euro Z 800 V instrument.
- Connect test leads to the object under test. See **Figure 6.95**. Refer to **MI 3144 Euro Z 800 V Instruction manual** for detailed information.

- Start the measurement using  or  button.
- Use  to select PASS / FAIL / NO STATUS indication.
- Press  or the  key to confirm selection and complete the measurement.
- Save results (optional).

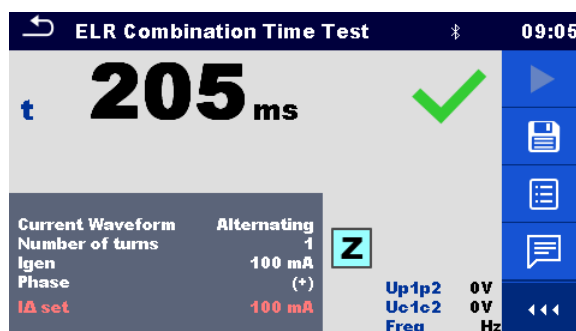

Figure 6.98: Example of ELR Combination Time Test result

6.2.28 Current Clamp Meter (MI 3144)

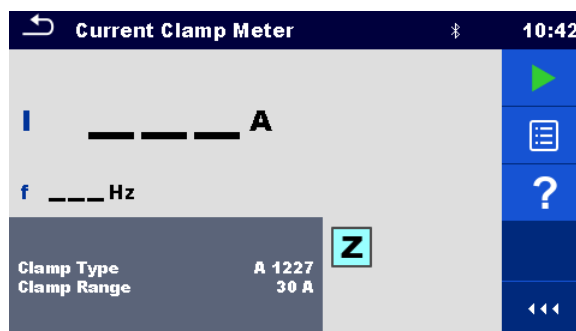

Figure 6.99: Current Clamp Meter menu

Test results / sub-results

I	Current
f	Frequency

Refer to *MI 3144 Euro Z 800 V Instruction manual* for detailed information.

Test parameters

Clamp Type	Clamp type [A 1227, A 1281, A 1609]
Clamp Range	Range: Clamp type A 1227, A 1609: [30 A, 300 A, 3000 A] Clamp type A 1281: [0.5 A, 5 A, 100 A, 1000 A]

Connection diagram

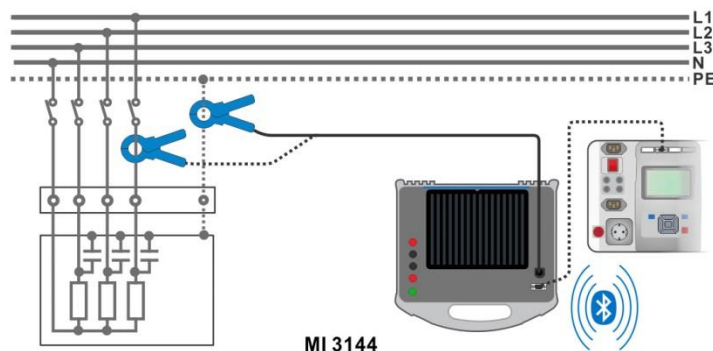



Figure 6.100: Current Clamp Meter measurement

Refer to *MI 3144 Euro Z 800 V Instruction manual* for detailed information.

Measurement procedure

- ▶ Connect MI 3325 instrument with MI 3144 Euro Z instrument via serial RS232 or pair them using Bluetooth communication. See chapter **4.7.3 Settings**.
- ▶ Enter the **Current Clamp Meter** function.
- ▶ Set test parameters / limits.
- ▶ Check Bluetooth communication active sign if MI 3144 Euro Z 800 V instrument is connected to MI 3325 instrument via Bluetooth communication.
- ▶ Connect current clamp to MI 3144 Euro Z 800 V instrument.
- ▶ Wrap the object under test with the measuring clamp. See **Figure 6.100**. Refer to *MI*

3144 Euro Z 800 V Instruction manual for detailed information.

- › Start the continuous measurement using  or  button.
- › Stop the measurement.
- › Save results (optional).

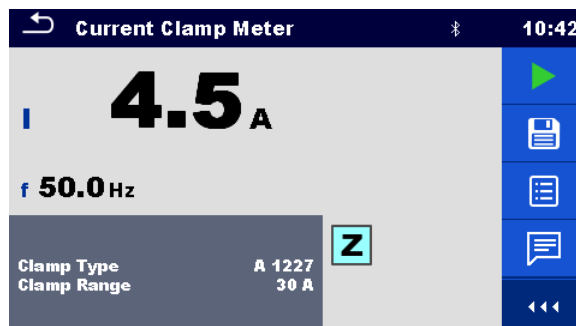

Figure 6.101: Example of Current Clamp Meter measurement result

6.2.29 EVSE Diagnostic Test (A 1632)

EVSE Diagnostic Test should be performed with A 1632 eMobility Analyser connected with MI 3325 instrument via Bluetooth communication.

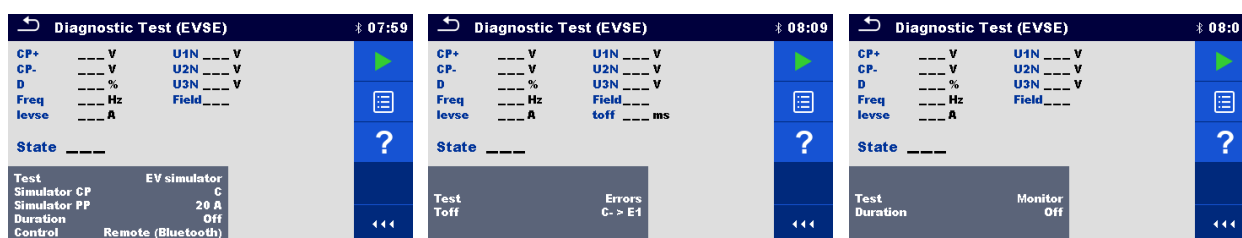

Figure 6.102: Diagnostic Test (EVSE) start screens – EV simulator, Errors and Monitor

Test results / sub-results

CP+	Maximal value of CP (control pilot) signal
CP-	Minimal value of CP (control pilot) signal
D	Duty cycle of CP (control pilot) signal
Freq	Frequency of CP (control pilot) signal
levse	Charging current available by charging cable / EVSE
U1N	Voltage UL1-N on the output of charging cable / EVSE
U2N	Voltage UL2-N on the output of charging cable / EVSE
U3N	Voltage UL3-N on the output of charging cable / EVSE
Field	1.2.3 – correct connection – CW rotation sequence 3.2.1 – invalid connection – CCW rotation sequence
toff	Disconnection time of charging cable / EVSE
State	System state

Refer to **A 1632 eMobility Analyser Instruction manual** for detailed information.

Test parameters

With selection of the Test parameter on the start screen, three diagnostic sub-tests can be set.

Test	Test [EV simulator, Monitor, Errors] <i>EV simulator</i> - Simulation of Electrical Vehicle <i>Monitor</i> - Monitoring of EVSE – EV interconnection and signalling <i>Errors</i> - Simulation of CP Errors
Toff	Simulated CP errors [C->E1, C->E2, C->E3, D->E1, D->E2, D->E3]
Simulator CP	CP (control pilot) state setting [nc, A, B, C, D]
Simulator PP	PP (proximity pilot) state setting [nc, 13 A, 20 A, 32 A, 63 A, 80 A]
Duration	Test duration [Off, 2 s, 3 s, 5 s, 10 s, 30 s, 60 s, 90 s, 120 s, 180 s]
Control	Analyser control [Remote (Bluetooth), Manual (A 1632)]

Connection diagram

Refer to **A 1632 – eMobility Analyser Instruction manual** for detailed information.



Figure 6.103: Diagnostic test - EV simulator and Errors sub-tests - connection to EVSE

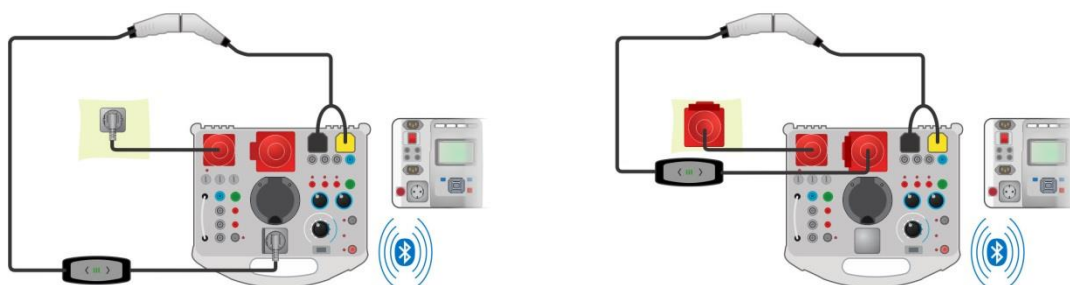

Figure 6.104: Diagnostic test - EV simulator and Errors sub-tests - connection to Mode 2 charging cable powered from Analyser

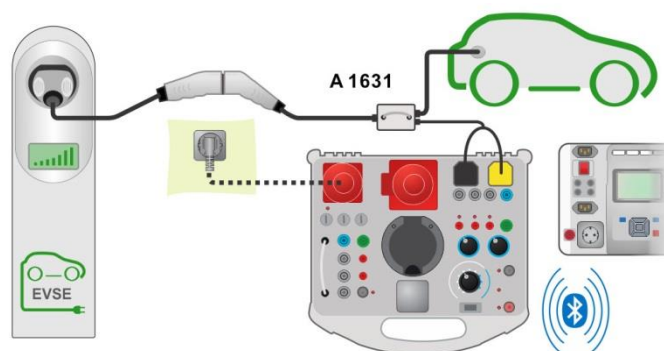



Figure 6.105: Diagnostic test (EVSE) - Monitor sub-test - connection to EVSE or charging cable

Diagnostic test procedure

- Pair and connect MI 3325 with A 1632 eMobility Analyser instrument via Bluetooth

communication. See chapter **4.7.3 Settings**.

- › Enter the **Diagnostic test (EVSE)** function.
- › Set test parameters / limits.
- › Check Bluetooth communication active sign if A 1632 eMobility Analyser is connected to MI 3325 instrument via Bluetooth communication.
- › Connect the charging cable / station to A 1632 eMobility Analyser adapter. See **Figure 6.103, Figure 6.104 and Figure 6.105**. Refer to **A 1632 eMobility Analyser Instruction manual** for detailed information.

- › Start the measurement using  or  button.
- › Manually apply status (optional).
- › Save results (optional).

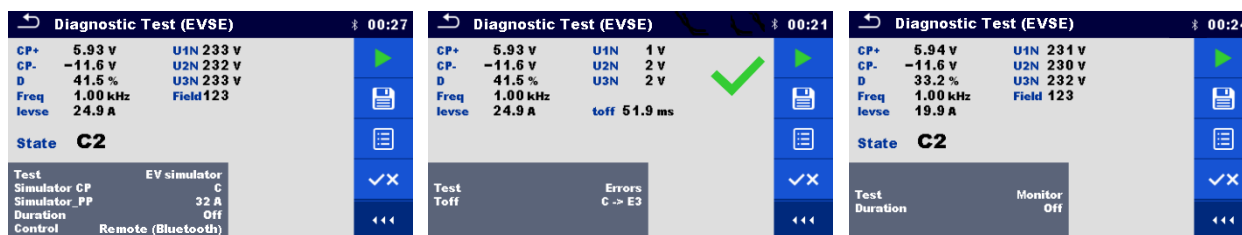

Figure 6.106: Examples of Diagnostic Test (EVSE) measurement results – EV simulator, Errors and Monitor

6.2.30 Rpe – PE conductor resistance



Figure 6.107: PE conductor resistance measurement menu

Test results / sub-results

Rpe PE conductor resistance

Test parameters

RCD [Yes, No]

Test limits

Limit(Rpe) Max. resistance [Off, Custom, 0.1 ... 20.0 Ω]

Connection diagram

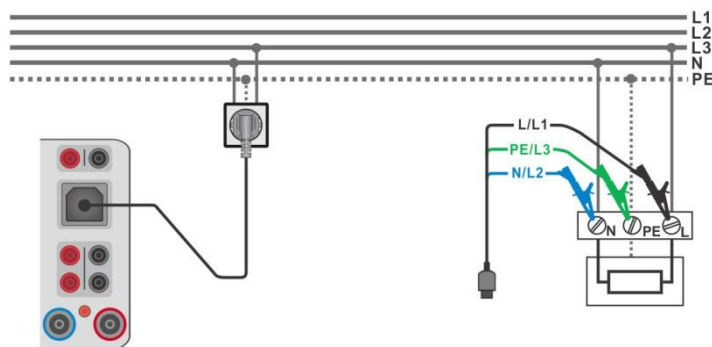

Figure 6.108: Connection of Plug test cable or 3-wire test leads

Measurement procedure

- ▶ Enter the **Rpe** function.
- ▶ Set test parameters / limits.
- ▶ Connect test cable to the instrument.
- ▶ Connect 3-wire test lead or Plug test cable to the object under test, see **Figure 6.108**.
- ▶ Start the measurement.
- ▶ Save results (optional).

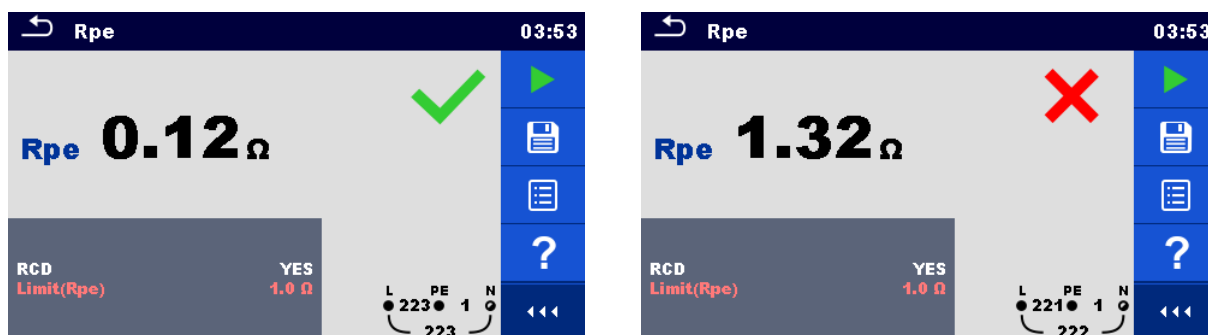

Figure 6.109: Examples of PE conductor resistance measurement result

6.2.31 R low – Resistance of earth connection and equipotential bonding

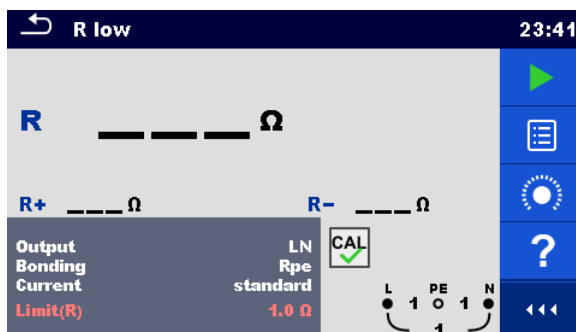

Figure 6.110: R low measurement menu

Test results / sub-results

R	Resistance
R+	Result at positive test polarity

R- Result at negative test polarity

Test parameters

Output ¹⁾	[LPE, LN]
Current	[standard, ramp]
Bonding	[Rpe, Local]

¹⁾ R low measurement depends on Output parameter setting, see table below.

Output:	Test terminals:
LN	L and N
LPE	L and PE

Table 6.7: Rlow measuring terminals and Output parameter dependency

Test limits

Limit(R)	Max. resistance [Off, Custom, 0.05 Ω ... 20.0 Ω]
-----------------	---

Connection diagram

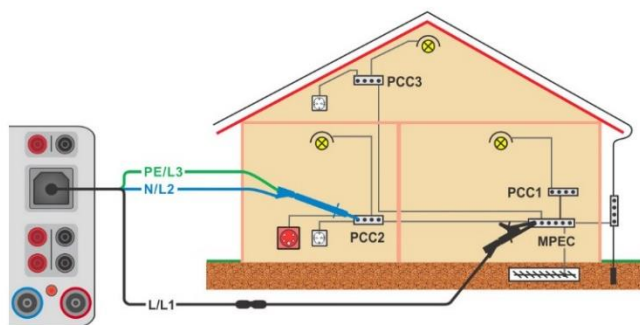

Figure 6.111: Connection of 3-wire test lead plus optional Extension lead

Measurement procedure

- › Enter the **R low** function.
- › Set test parameters / limits.
- › Connect 3-wire test lead to the instrument.
- › Compensate the test leads resistance, if necessary, see chapter **6.2.31.1 Compensation of test leads resistance**.
- › Disconnect tested installation from mains supply and discharge insulation as required.
- › Connect test leads, see **Figure 6.111**.
- › Start the measurement.
- › Save results (optional).

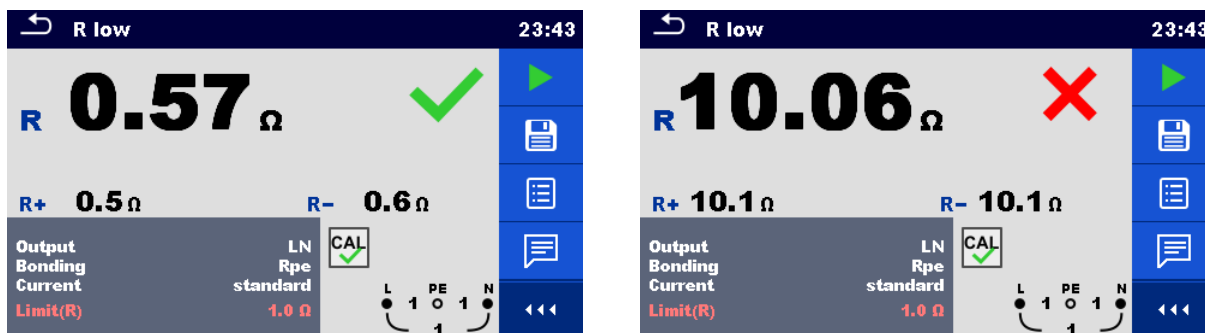

Figure 6.112: Examples of R low measurement result

6.2.31.1 Compensation of test leads resistance (Rlow)

This chapter describes how to compensate the test leads resistance in **Rlow** function. Compensation is required to eliminate the influence of test leads resistance and the internal resistances of the instrument on the measured resistance. The test leads compensation is therefore a very important feature to obtain correct result.

 symbol is displayed if the compensation was carried out successfully.

Connections for compensating the resistance of test leads

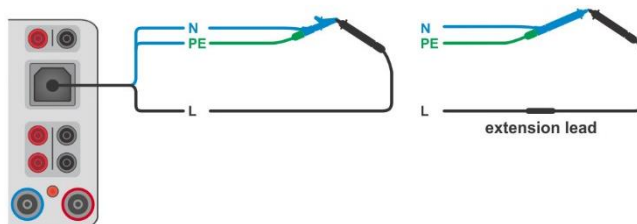



Figure 6.113: Shorted test leads

Compensation of test leads resistance procedure

- › Enter **R low** function.
- › Connect test cable to the instrument and short all test leads together, see **Figure 6.113**.
- › Touch the  key to compensate leads resistance.

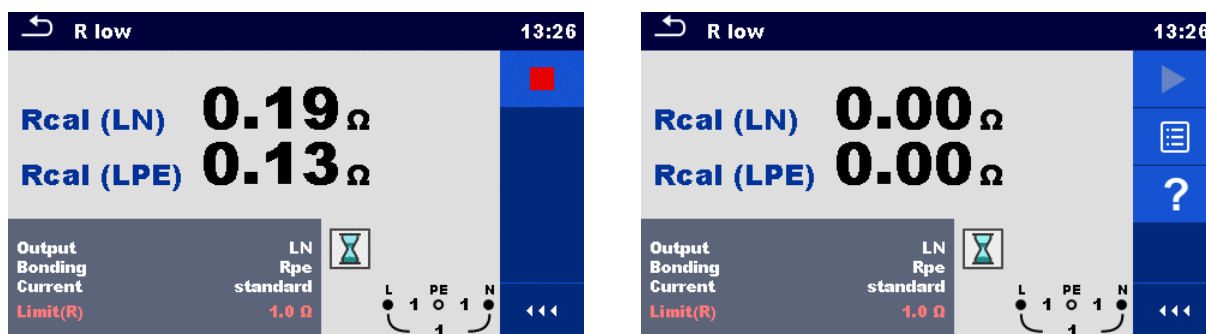

Figure 6.114: Result with old and new calibration values

6.2.32 PRCD test (A 1322, A 1422)

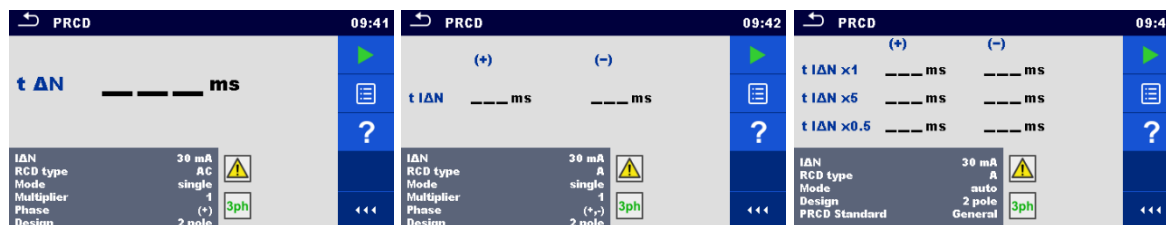

Figure 6.115: PRCD measurement menu

Test results / sub-results

- t ΔNtrip out time
- t IΔN (+)trip-out time ((+) positive polarity)
- t IΔN (-)trip-out time ((-) negative polarity)

- t I Δ N x1, (+)trip-out time (I Δ =I Δ N, (+) positive polarity)
- t I Δ N x1, (-)trip-out time (I Δ =I Δ N, (-) negative polarity)
- t I Δ N x5, (+)trip-out time (I Δ =5xI Δ N, (+) positive polarity)
- t I Δ N x5, (-)trip-out time (I Δ =5xI Δ N, (-) negative polarity)
- t I Δ N x0.5, (+)trip-out time (I Δ =1/2xI Δ N, (+) positive polarity)
- t I Δ N x0.5, (-)trip-out time (I Δ =1/2xI Δ N, (-) negative polarity)
- I Δ trip out current
- I Δ (+)trip-out current ((+) positive polarity)
- I Δ (-)trip-out current ((-) negative polarity)

Test parameters

I Δ N	Nominal current [10 mA, 15 mA, 30 mA, 100 mA, 300 mA]
RCD Type	PRCD Type [AC, A, F, B, B+]
Mode	Test mode [single, auto]
Multiplier	Multiplication factor I Δ N [0.5, 1, 5]
Phase	Starting polarity in single mode [(+), (-), (+,-)]
Design	Design type [2 pole, 3 pole, S (3 pole), S+]
PRCD Standard	PRCD standard [General]

Test limits

Test limits for Pass / Fail statuses are set automatically, depending on set parameters.

PRCD measurement procedure

- › Select the PRCD function.
- › Set test parameters.
- › Connect METREL 3-phase adapter (A 1322 or A 1422) to the instrument*.
- › Connect the PRCD to the 3-phase adapter*.
- › Start measurement.
- › Switch ON the PRCD when prompted on the display.
- › Reactivate PRCD when prompted on the display.
- › Save results (optional).

*For more information refer to chapter *3-phase RCD test* in 3-phase AktivGT / Machine adapter Plus A 1322 / A 1422 user manual.

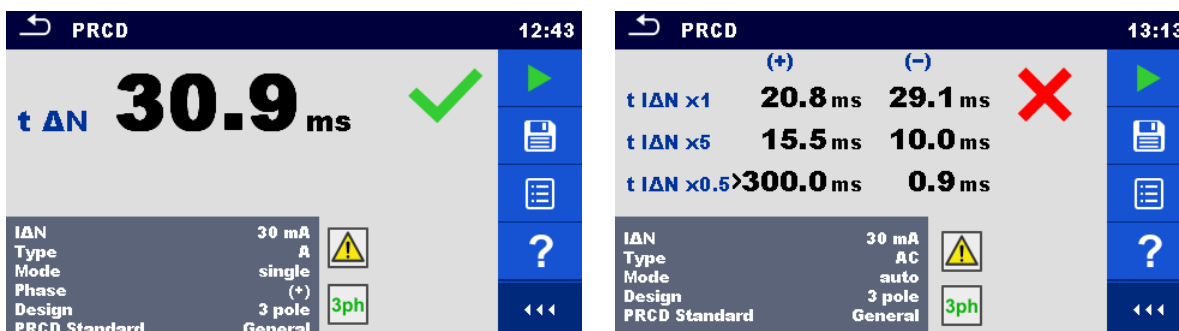

Figure 6.116: Examples of PRCD measurement results

Note:

- › This test is applicable only with connected METREL 3-phase adapters (A 1322, A 1422).

6.2.33 PE conductor (PRCD)

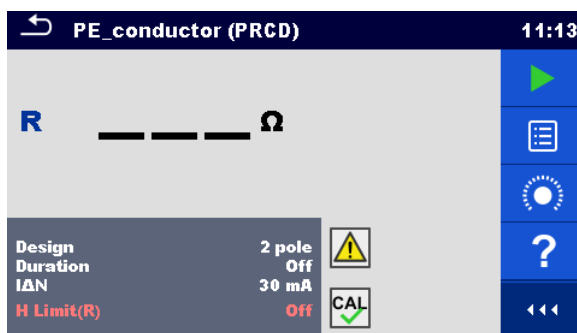

Figure 6.117: PE conductor (PRCD) test menu

Test results / sub-results

R..... Resistance



Test parameters

Design	Type of PRCD [2 pole, 3 pole, S (3 pole), S+]
Duration	Duration [Off, 2 s ... 180 s]
IAN	Nominal current [10 mA, 15 mA, 30 mA, 100 mA, 300 mA]

Test limits

H Limit(R)	Limit [Off, Custom, 0.01 Ω ... 9 Ω]
-------------------	-------------------------------------

Specific options

	Calibrate - Compensation of test lead / IEC test cable resistance. Refer to chapter 6.2.2.1 for procedure details.
	Lim. Calculator – PE_conductor(PRCD) resistance H Limit(R) calculator. Refer to chapter 6.2.2.2 for details.

Test circuit



Figure 6.118: PE conductor (PRCD) test

PE conductor (PRCD) measurement procedure

- › Select the **PE conductor (PRCD)** function.
- › Set test parameters / limits.
- › Compensate IEC plug adapter (optional).
- › Connect device under test to the instrument (see test circuit above).

- › Start measurement.
- › Switch ON the PRCD within 8 s when prompted on the display. Measurement can be stopped manually or by timer.
- › Save results (optional).



Figure 6.119: Examples of PE conductor (PRCD) results

Note:

- › Mains voltage is applied to the PRCD during the test.
- › L and N conductors are not allowed to be crossed in this test. Reconnect the PRCD's plug after pre-test, if requested.

6.2.34 RCD Uc – Contact voltage

Warning!

- › MI 3325 checks voltage on RCD-PE before running test and disables test in case the hazardous live voltage is detected. In this case, immediately remove supply from tested circuit, find, and eliminate problem before any other activity! See chapter 1.2 Testing potential on TP1-PE terminal for installation tests for more information.

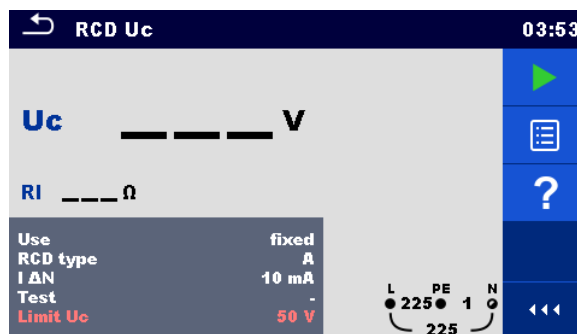

Figure 6.120: RCD Uc – Contact voltage test menu

Test results / sub-results

Uc	Contact voltage
RI	Fault loop resistance

Test parameters

Use	RCD / PRCD selection [fixed, PRCD-2p, PRCD-3p, PRCD-S, PRCD-S+, PRCD-K, other]
Selectivity	Characteristic [G, S]
RCD type	RCD type [AC, A, F, B, B+, EV RCD ¹⁾ , MI RCD ¹⁾ , EV RCM ¹⁾]

I_{ΔN}	Rated RCD residual current sensitivity [10 mA, 15 mA, 30 mA, 100 mA, 300 mA, 500 mA, 1000 mA]
I_{ΔN} / I_{ΔNdc}	Rated RCD residual current sensitivity for special RCDs types [30 mA / 6 mA d.c., - / 6 mA d.c.] ¹⁾
Test	Test [-, L/PE, L1/PE, L2/PE, L3/PE]
Sensitivity	Sensitivity [standard, I _{pe} monitoring] ²⁾
RCD Standard	RCD standard selection [EN 61008 / EN 61009, IEC 60364-4-41 TN/IT, IEC 60364-4-41 TT, BS 7671, AS/NZS 3017, VDE 0664, VDE 0100-410 TN/IT, VDE 0100-410 TT]
EV RCD/RCM Standard	EV RCD/RCM standard selection [IEC 62752, IEC 62955] ¹⁾
Earthing System	Earthing system [TN/TT, IT]

- 1) Parameter is available only when parameter Use is set to other (for Electrical Vehicle (EV) RCDs/RCMs and Mobile installations (MI) RCDs).
- 2) Parameter is available only when parameter 'Use' is set to PRCD, PRCD-3p, PRCD-S+ or PRCD-K.

Test limits

Limit Uc	Conventional touch voltage limit [Custom, 12 V, 25 V, 50 V]
-----------------	---

Test circuit

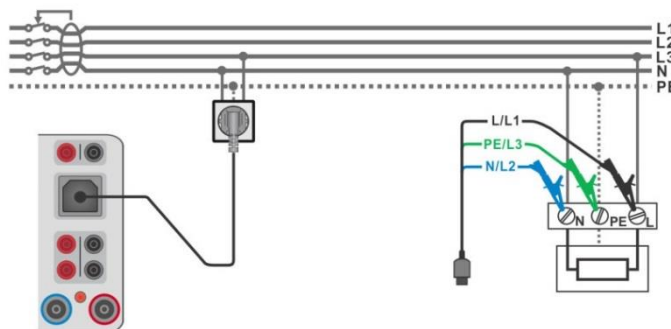

Figure 6.121: Connecting the Plug test cable or the 3-wire test lead

Test procedure

- Enter the **RCD Uc** function.
- Set test parameters / limits.
- Connect test cables to the instrument TP1 test connector.
- Connect 3-wire test lead or Plug test cable to the object under test, see **Figure 6.121**.
- Start the measurement.
- Save results (optional).

The contact voltage result relates to the rated nominal residual current of the RCD and is multiplied by an appropriate factor (depending on RCD type and type of test current). The 1.05 factor is applied to avoid negative tolerance of result. See **Table 6.8** for detailed contact voltage calculation factors.

RCD type		Contact voltage Uc proportional to	Rated I _{ΔN}
AC, EV, MI (a.c. part)	G	1.05×I _{ΔN}	any
	S	2×1.05×I _{ΔN}	
A, F	G	1.4×1.05×I _{ΔN}	≥ 30 mA
	S	2×1.4×1.05×I _{ΔN}	

A, F	G	$2 \times 1.05 \times I_{\Delta N}$	< 30 mA
A, F	S	$2 \times 2 \times 1.05 \times I_{\Delta N}$	
B, B+	G	$2 \times 1.05 \times I_{\Delta N}$	any
B, B+	S	$2 \times 2 \times 1.05 \times I_{\Delta N}$	

Table 6.8: Relations between U_c and $I_{\Delta N}$

Fault Loop resistance is indicative and calculated from U_c result (without additional proportional factors) according to: $R_L = \frac{U_c}{I_{\Delta N}}$.

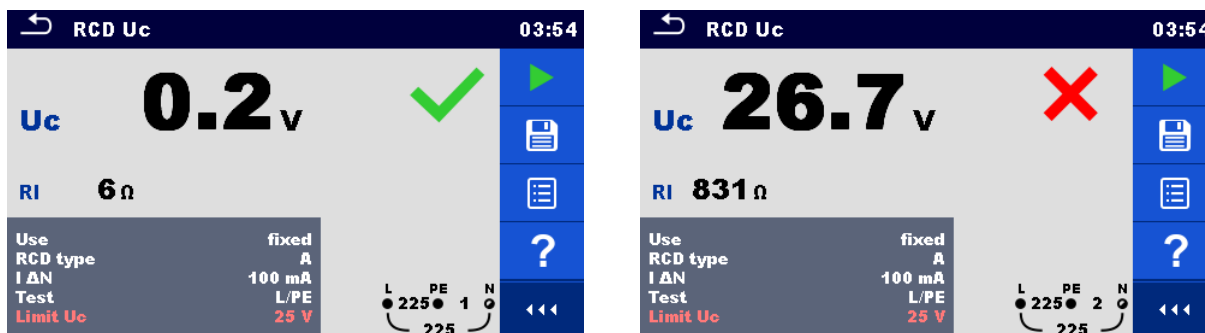

Figure 6.122: Examples of Contact voltage measurement result

6.2.35 RCD t – Trip-out time

Warning!

- MI 3325 checks voltage on RCD-PE before running test and disables test in case the hazardous live voltage is detected. In this case, immediately remove supply from tested circuit, find, and eliminate problem before any other activity! See chapter 1.2 Testing potential on TP1-PE terminal for installation tests for more information.

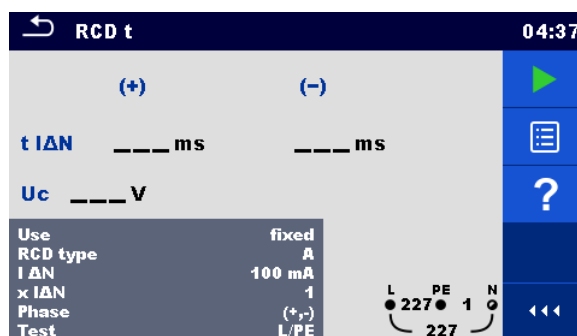

Figure 6.123: Trip-out time RCD t test menu

Test results / sub-results

$t_{\Delta N}$	Trip-out time
$t_{I\Delta N (+)}$	Trip-out time ((+) positive polarity)
$t_{I\Delta N (-)}$	Trip-out time ((-) negative polarity)
U_c	Contact voltage

Test parameters

Use	RCD / PRCD selection [fixed, PRCD, PRCD-2p, PRCD-3p, PRCD-S, PRCD-S+, PRCD-K, other]
Selectivity	Characteristic [G, S]
Type	RCD type [AC, A, F, B, B+, EV RCD ¹⁾ , MI RCD ¹⁾ , EV RCM ¹⁾]
I ΔN	Rated RCD residual current sensitivity [10 mA, 15 mA, 30 mA, 100 mA, 300 mA, 500 mA, 1000 mA]
I ΔN/ I ΔNdc	Rated RCD residual current sensitivity for special RCDs types [30 mA / 6 mA d.c., - / 6 mA d.c.] ¹⁾
X IΔN	Multiplication factor for test current [0.5, 1, 2, 5]
x IΔN d.c.	Multiplication factor for d.c. test current [0.5, 1, 10, 33.33, 50] ¹⁾
Phase	Starting polarity [(+), (-), (+,-)]
Test	Test [-, L/PE, L1/PE, L2/PE, L3/PE]
Test	Test current shape [a.c., d.c.] ³⁾
Sensitivity	Sensitivity [standard, I _{pe} monitoring] ²⁾
RCD standard	RCD standard [EN 61008 / EN 61009, IEC 60364-4-41 TN/IT, IEC 60364-4-41 TT, BS 7671, AS/NZS 3017, VDE 0664, VDE 0100-410 TN/IT, VDE 0100-410 TT]
EV RCD/RCM Standard	EV RCD/RCM standard selection [IEC 62752, IEC 62955] ¹⁾
Earthing System	Earthing system [TN/TT, IT]

- 1) Parameter is available only when parameter Use is set to other (for Electrical Vehicle (EV) RCDs/RCMs and Mobile installations (MI) RCDs).
- 2) Parameter is available only when parameter 'Use' is set to PRCD, PRCD-3p, PRCD-S+ or PRCD-K.
- 3) Parameter is available only when RCD I or RCD t test is selected and parameter Use is set to 'other'.

Test limits

Limit Uc	Conventional touch voltage limit [Custom, 12 V, 25 V, 50 V]
-----------------	---

Test circuits

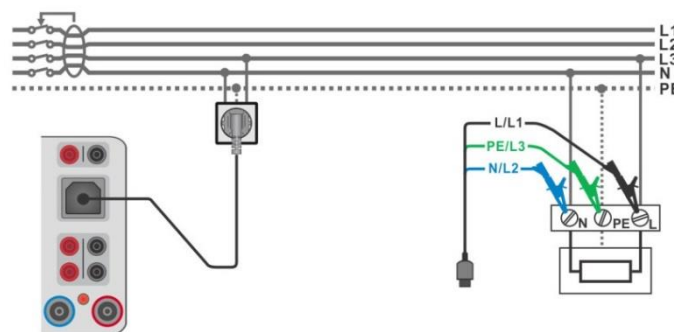



Figure 6.124: Connecting the Plug test cable or the 3-wire test lead (fixed RCDs)



Figure 6.125: Connecting portable RCDs (PRCDs)

Test procedure

- › Enter the **RCD t** function.
- › Set test parameters / limits.
- › Connect test cable to the instrument TP1 test connector.
- › Connect 3-wire test lead or Plug test cable to the object under test.
- › Connect PRCD input to instrument Test socket and turn on socket mains . (if applicable)
- › Start the measurement.
- › Reactivate RCD / PRCD when prompted on the display.
- › Save results (optional).

Notes:

- › Re-activate RCD / PRCD when prompted on the display.
- › Uc sub-result is not displayed if PRCD is connected to Test socket.

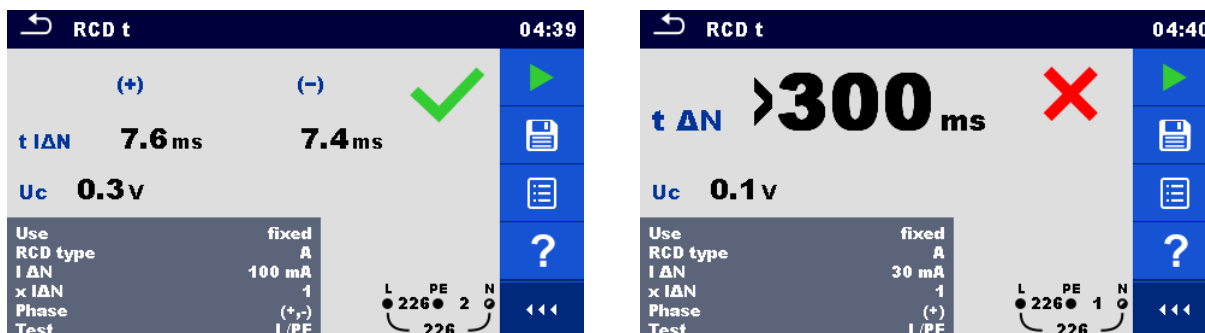

Figure 6.126: Examples of Trip-out time measurement result

6.2.36 RCD I – Trip-out current

Warning!

- › MI 3325 checks voltage on RCD-PE before running test and disables test in case the hazardous live voltage is detected. In this case, immediately remove supply from tested circuit, find, and eliminate problem before any other activity! See chapter 1.2 *Testing potential on TP1-PE terminal for installation tests* for more information.

The instrument increases the test current in small steps through appropriate range as follows:

RCD type	Slope range		Waveform
	Start value	End value	
AC	$0.2 \times I_{\Delta N}$	$1.1 \times I_{\Delta N}$	Sine
IEC 62752: EV RCD, EV RCM, MI RCD (a.c. part)	$0.2 \times I_{\Delta N}$	$1.0 \times I_{\Delta N}$	Sine
IEC 62955: EV RCD, EV RCM, MI RCD (a.c. part)	$0.2 \times I_{\Delta N}$	$1.0 \times I_{\Delta N}$	Sine
A, F ($I_{\Delta N} \geq 30 \text{ mA}$)	$0.2 \times I_{\Delta N}$	$1.5 \times I_{\Delta N}$	Pulsed
A, F ($I_{\Delta N} = 10 \text{ mA}$)	$0.2 \times I_{\Delta N}$	$2.2 \times I_{\Delta N}$	
B, B+	$0.2 \times I_{\Delta N}$	$2.2 \times I_{\Delta N}$	DC
IEC 62752: EV RCD, EV RCM, MI RCD (d.c. part)	1.2 mA	6.0 mA	DC
IEC 62955: EV RCD, EV RCM, MI RCD (d.c. part)	1.2 mA	6.0 mA	DC

Table 6.9: Relations between RCD type, slope range and test current

Maximum test current is I_{Δ} (trip-out current) or end value in case the RCD didn't trip-out.

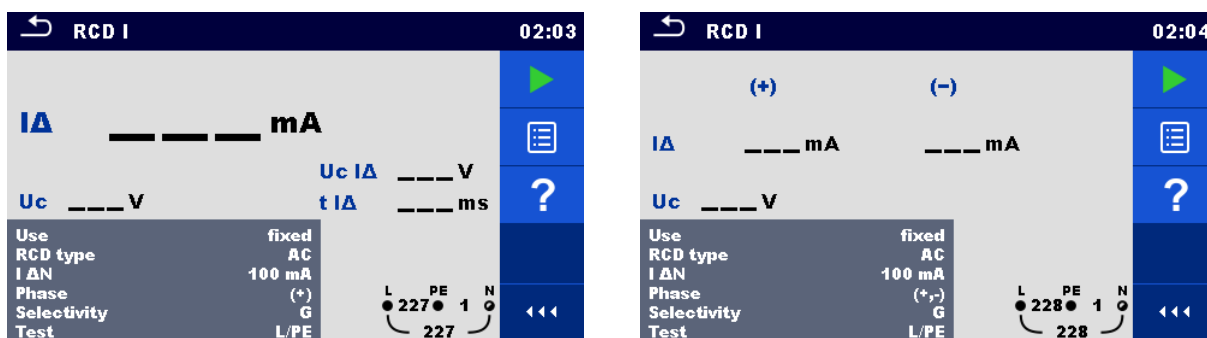

Figure 6.127: Trip-out current RCD I test menu

Test results / sub-results

I_{Δ}	Trip-out current
$I_{\Delta} (+)$	Trip-out current ((+) positive polarity)
$I_{\Delta} (-)$	Trip-out current ((-) negative polarity)
$U_c I_{\Delta}$	Contact voltage at trip-out current I_{Δ}
$t I_{\Delta}$	Trip-out time at trip-out current I_{Δ}
U_c	Contact voltage

Test parameters

Use	RCD / PRCD selection [fixed, PRCD, PRCD-2p, PRCD-3p, PRCD-S, PRCD-S+, PRCD-K, other]
Selectivity	Characteristic [G, S]
Type	RCD type [AC, A, F, B, B+, EV RCD ¹⁾ , MI RCD ¹⁾ , EV RCM ¹⁾]
$I_{\Delta N}$	Rated RCD residual current sensitivity [10 mA, 15 mA, 30 mA, 100 mA, 300 mA, 500 mA, 1000 mA]
$I_{\Delta N} / I_{\Delta Ndc}$	Rated RCD residual current sensitivity for special RCDs types [30 mA / 6 mA d.c., - / 6 mA d.c.] ¹⁾
Phase	Starting polarity [(+),(-), (+,-)]
Test	Test [-, L/PE, L1/PE, L2/PE, L3/PE]
Test	Test current shape [a.c., d.c.] ³⁾
Sensitivity	Sensitivity [standard, lpe monitoring] ²⁾

RCD standard	RCD standard [EN 61008 / EN 61009, IEC 60364-4-41 TN/IT, IEC 60364-4-41 TT, BS 7671, AS/NZS 3017, VDE 0664, VDE 0100-410 TN/IT, VDE 0100-410 TT]
EV RCD/RCM Standard	EV RCD/RCM standard selection [IEC 62752, IEC 62955] ¹⁾
Earthing System	Earthing system [TN/TT, IT]

- 1) Parameter is available only when parameter Use is set to other (for Electrical Vehicle (EV) RCDs/RCMs and Mobile installations (MI) RCDs).
- 2) Parameter is available only when parameter 'Use' is set to PRCD, PRCD-3p, PRCD-S+ or PRCD-K.
- 3) Parameter is available only when RCD I or RCD t test is selected and parameter Use is set to 'other'.

Test limits

Limit Uc	Conventional touch voltage limit [Custom, 12 V, 25 V, 50 V]
-----------------	---

Test circuits

See **Figure 6.124: Connecting the Plug test cable or the 3-wire test lead (fixed RCDs)** and **Figure 6.125: Connecting portable RCDs (PRCDs)** for details.

Test procedure

- › Enter the **RCD I** function.
- › Set test parameters / limits.
- › Connect test cable to the instrument TP1 test connector.
- › Connect 3-wire test lead or Plug test cable to the object under test.
- › Connect PRCD input to instrument Test socket and turn on socket mains . (if applicable)
- › Start the measurement.
- › Reactivate RCD / PRCD when prompted on the display.
- › Save results (optional).

Notes:

- › Re-activate RCD / PRCD when prompted on the display.
- › Uc and Uc IΔ sub-results are not displayed if PRCD is connected to Test socket.

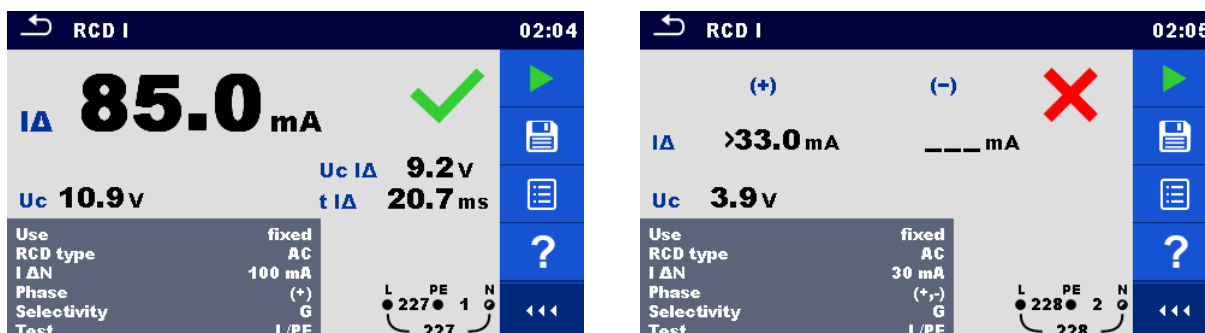

Figure 6.128: Examples of Trip-out current measurement result

6.2.37 RCD Auto – RCD Auto test

Warning!

- MI 3325 checks voltage on RCD-PE before running test and disables test in case the hazardous live voltage is detected. In this case, immediately remove supply from tested circuit, find, and eliminate problem before any other activity! See chapter 1.2 *Testing potential on TP1-PE terminal for installation tests* for more information.

RCD Auto test function performs a complete RCD test (trip-out time at different residual currents, trip-out current and contact voltage) in one set of automatic tests, guided by the instrument.

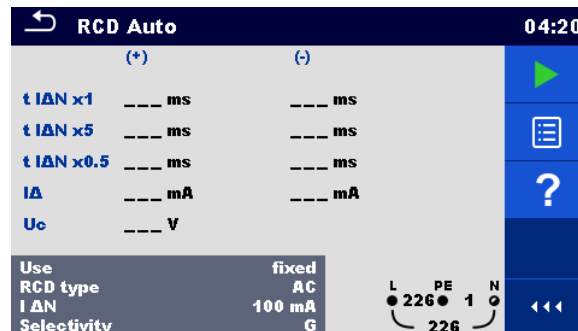

Figure 6.129: RCD Auto test menu

Test results / sub-results

t IΔN d.c. x1, (+) ¹⁾	Step 1 trip-out time (IΔ=IΔN d.c., (+) positive polarity)
t IΔN d.c. x1, (-) ¹⁾	Step 2 trip-out time (IΔ=IΔN d.c., (-) negative polarity)
t IΔN x1, (+)	Step 3 trip-out time (IΔ=IΔN, (+) positive polarity)
t IΔN x1, (-)	Step 4 trip-out time (IΔ=IΔN, (-) negative polarity)
t IΔN x5, (+)	Step 5 trip-out time (IΔ=5×IΔN, (+) positive polarity)
t IΔN x5, (-)	Step 6 trip-out time (IΔ=5×IΔN, (-) negative polarity)
t IΔN x0.5, (+)	Step 7 trip-out time (IΔ=½×IΔN, (+) positive polarity)
t IΔN x0.5, (-)	Step 8 trip-out time (IΔ=½×IΔN, (-) negative polarity)
IΔ (+)	Step 9 trip-out current ((+) positive polarity)
IΔ (-)	Step 10 trip-out current ((-) negative polarity)
IΔ d.c. (+) ¹⁾	Step 9 trip-out current ((+) positive polarity)
IΔ d.c. (-) ¹⁾	Step 10 trip-out current ((-) negative polarity)
Uc	Contact voltage for rated IΔN

¹⁾ Result is displayed only when parameter Use is set to 'other' and parameter Type to 'EV RCD', 'EV RCM' or 'MI RCD'.

Test parameters

Use	RCD / PRCD selection [fixed, PRCD, PRCD-2p, PRCD-3p, PRCD-S, PRCD-S+, PRCD-K]
Selectivity	Characteristic [G, S]
Type	RCD type [AC, A, F, B, B+, EV RCD ¹⁾ , MI RCD ¹⁾ , EV RCM ¹⁾]
I ΔN	Rated RCD residual current sensitivity [10 mA, 15 mA, 30 mA, 100 mA, 300 mA, 500 mA, 1000 mA]
I ΔN/ I ΔNdc	Rated RCD residual current sensitivity for special RCDs types [30 mA / 6 mA d.c., - / 6 mA d.c.] ¹⁾

Test	Test [-, L/PE, L1/PE, L2/PE, L3/PE]
Test	Test current shape [a.c., d.c.] ³⁾
Sensitivity	Sensitivity [standard, I _{pe} monitoring] ²⁾
RCD standard	RCD standard [EN 61008 / EN 61009, IEC 60364-4-41 TN/IT, IEC 60364-4-41 TT, BS 7671, AS/NZS 3017, VDE 0664, VDE 0100-410 TN/IT, VDE 0100-410 TT]
EV RCD/RCM Standard	EV RCD/RCM standard selection [IEC 62752, IEC 62955] ¹⁾
Earthing System	Earthing system [TN/TT, IT]

- ¹⁾ Parameter is available only when parameter Use is set to other (for Electrical Vehicle (EV) RCDs/RCMs and Mobile installations (MI) RCDs).
- ²⁾ Parameter is available only when parameter 'Use' is set to PRCD, PRCD-3p, PRCD-S+ or PRCD-K.
- ³⁾ Parameter is available only when RCD I or RCD t test is selected and parameter Use is set to 'other'.

Test limits

Limit Uc	Conventional touch voltage limit [Custom, 12 V, 25 V, 50 V]
-----------------	---

Test circuits

See **Figure 6.124: Connecting the Plug test cable or the 3-wire test lead (fixed RCDs)** and **Figure 6.125: Connecting portable RCDs (PRCDs)** for details.

RCD Auto test procedure

RCD Auto test steps	Notes
<ul style="list-style-type: none"> › Enter the RCD Auto function. › Set test parameters / limits. › Connect test cable to the instrument TP1 test connector. › Connect 3-wire test lead or Plug test cable to the test object. › Connect PRCD input to instrument Test socket and turn on socket mains . (if applicable) 	
› Start the measurement.	Start of test
Test with I _{ΔN} d.c., (+) positive polarity. ¹⁾	RCD / PRCD should trip-out
› Re-activate RCD / PRCD.	
Test with I _{ΔN} d.c., (-) negative polarity. ¹⁾	RCD / PRCD should trip-out
› Re-activate RCD / PRCD.	
Test with I _{ΔN} , (+) positive polarity. ²⁾	RCD / PRCD should trip-out RCD / PRCD should not trip-out during non-operating time for a.c. residual current (IEC 62955)
› Re-activate RCD / PRCD if required.	
Test with I _{ΔN} , (-) negative polarity. ²⁾	RCD / PRCD should trip-out RCD / PRCD should not trip-out during non-operating time for a.c. residual current (IEC 62955)
› Re-activate RCD / PRCD.	
Test with 5×I _{ΔN} , (+) positive polarity. ²⁾	RCD / PRCD should trip-out
› Re-activate RCD / PRCD.	

Test with $5 \times I_{\Delta N}$, (-) negative polarity. ²⁾	RCD / PRCD should trip-out
› Re-activate RCD / PRCD.	
Test with $\frac{1}{2} \times I_{\Delta N}$, (+) positive polarity. ²⁾	RCD / PRCD should not trip-out
Test with $\frac{1}{2} \times I_{\Delta N}$, (-) negative polarity. ²⁾	RCD / PRCD should not trip-out
Trip-out current test, (+) positive polarity. ²⁾	RCD / PRCD should trip-out
› Re-activate RCD / PRCD.	
Trip-out current test, (-) negative polarity. ²⁾	RCD / PRCD should trip-out
› Re-activate RCD / PRCD.	
Trip-out current test for d.c. part, (+) positive polarity. ¹⁾	RCD / PRCD should trip-out
› Re-activate RCD / PRCD.	
Trip-out current test for d.c. part, (-) negative polarity. ¹⁾	RCD / PRCD should trip-out
› Re-activate RCD / PRCD.	
Save results (optional).	End of test

¹⁾ Steps are performed only when parameter Use is set to 'other' and parameter Type is set to 'EV RCD', 'EV RCM' or 'MI RCD'. Trip-out times are measured according to IEC 62752 or IEC 62955.

²⁾ When parameter Use is set to 'other' and parameter Type is set to 'EV RCD', 'EV RCD' or 'MI RCD', trip-out times or non-operating times for a.c. residual current are measured according to IEC 62752 or IEC 62955.

Notes:

- › Re-activate RCD / PRCD when prompted on the display.
- › Uc sub-result is not displayed if PRCD is connected to Test socket.

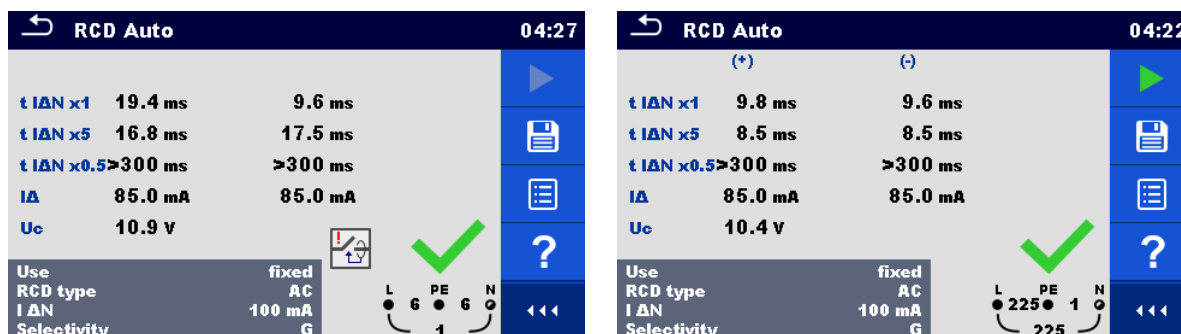

Figure 6.130: Examples of RCD Auto test result screens

6.2.38 HV AC

⚠ IMPORTANT SAFETY NOTES

Refer to chapter 1.1 *Warnings and notes* for more information regarding safe use of the instrument.

- › **Requirements from EN 50191 for test installations and safety of withstanding voltage testing shall be applied. Prohibition zone is 30 mm and no part of the body can be closer to tested item. Two hands must strictly be in operation during testing, one for manipulation with one of the HV test tips and another with manipulation with the HV START button on the MI 3325.**
- › **If necessary, the test place shall be guarded by barrier or similar, preventing any other person to reach testing place.**
- › **Red light in proximity of the instrument HV outputs warns when dangerous voltage is present on HV outputs.**
- › **Disconnect and keep in safe place all unused test leads before starting this measurement; otherwise, the instrument can be damaged!**

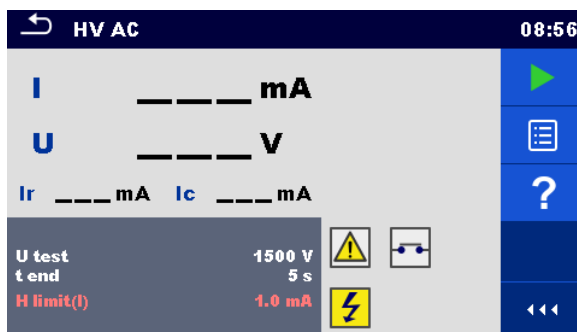

Figure 6.131: HV AC test menu

Test results / sub-results

- I test current
- U measured a.c. test voltage
- Ir resistive portion of test current
- Ic capacitive portion of test current

Test parameters

U test	AC test voltage [100 V ... 5100 V in steps of 10 V]
t end	Test duration [Off, 1 s ... 120 s]

Test limits

H limit (I)	High limit [Custom, 0.5 mA ... 100 mA]
--------------------	--

Test circuit

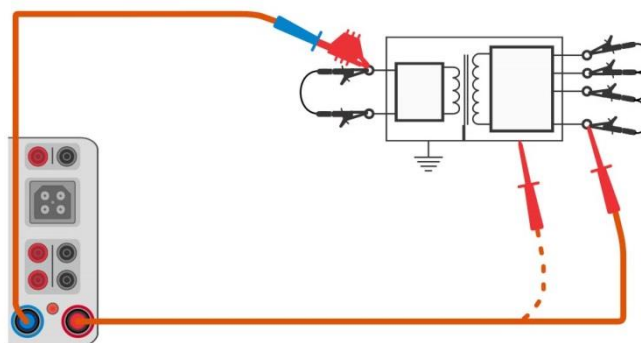

Figure 6.132: HV AC measurement

HV AC measurement procedure

- › Prepare test setup as mentioned in IMPORTANT SAFETY NOTES above.
- › Select the **HV AC** function.
- › Set test parameters / limits.
- › Connect HV test leads to HV terminals on the instrument.
- › Connect HV test leads to device under test.
- › Start measurement.
- › Measurement can be stopped manually or by timer.
- › Save results (optional).

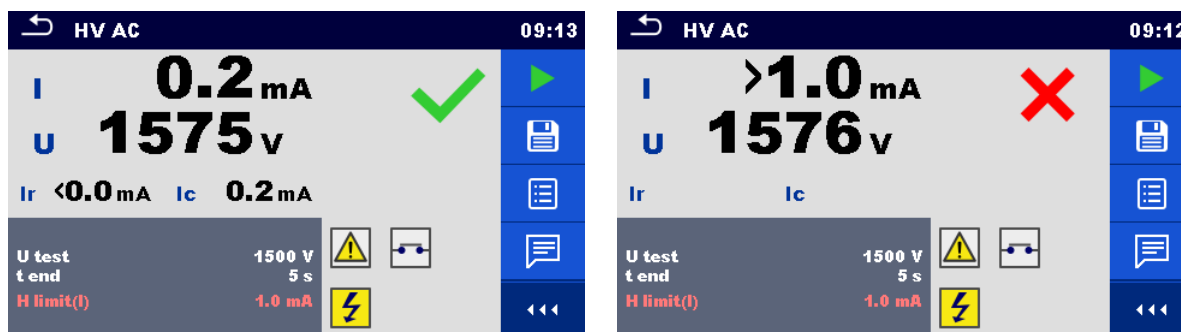

Figure 6.133: Examples of HV AC measurement results

Note:

- First HV measurement after power on the instrument (if password protection is enabled) or first HV measurement after enabling or changing password require entering password for enabling HV test. Refer to chapter **4.7.4 Change password for HV functions** for more information.

6.2.39 HV AC programmable

⚠ IMPORTANT SAFETY NOTES

Refer to chapter **1.1 Warnings and notes** for more information regarding safe use of the instrument.

- Requirements from EN 50191 for test installations and safety of withstanding voltage testing shall be applied. Prohibition zone is 30 mm and no part of the body can be closer to tested item. Two hands must strictly be in operation during testing, one for manipulation with one of the HV test tips and another with manipulation with the HV START button on the MI 3325.
- If necessary, the test place shall be guarded by barrier or similar, preventing any other person to reach testing place.
- Red light in proximity of the instrument HV outputs warns when dangerous voltage is present on HV outputs.
- Disconnect and keep in safe place all unused test leads before starting this measurement; otherwise the instrument can be damaged!

In the HV AC programmable test, the time dependency of high voltage can be set according to diagram on **Figure 6.134**.

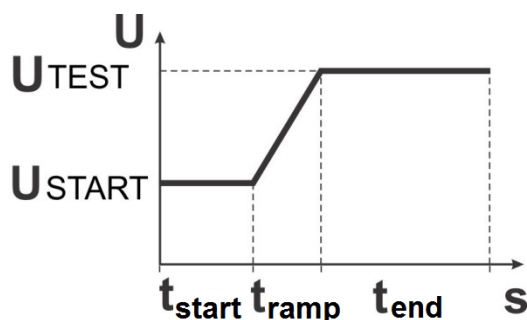

Figure 6.134: Voltage / time diagram of the HV AC programmable test

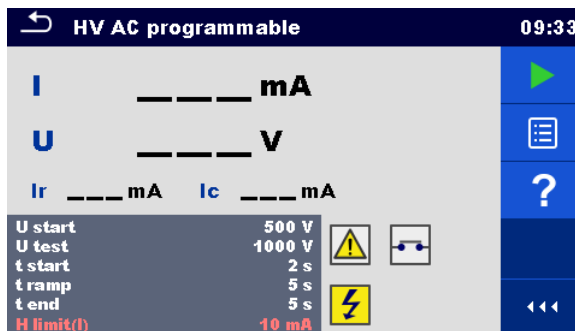

Figure 6.135: HV AC programmable test menu

Test results / sub-results

- I..... test current
- U measured test voltage
- Ir resistive portion of test current
- Ic capacitive portion of test current

Test parameters

U start	Starting AC test voltage [100 V ... 5100 V in steps of 10 V]
U test	AC test voltage [100 V ... 5100 V in steps of 10 V]
t start	Duration of starting voltage [1 s ... 120 s]
t ramp	Duration of ramp [2 s ... 60 s]
t end	Duration of test voltage [Off, 1 s ... 120 s]

Test limits

H limit (I)	High limit [Custom, 0.5 mA ... 100 mA]
--------------------	--

Test circuit

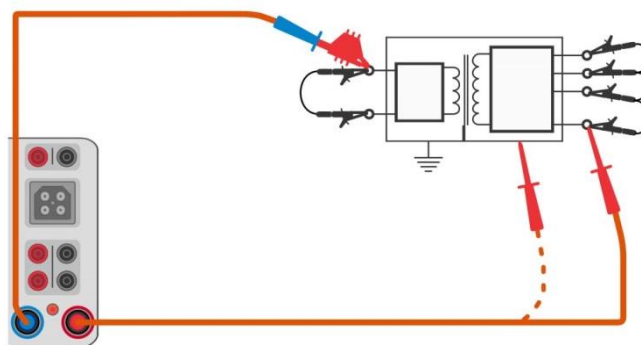

Figure 6.136: HV AC programmable test

HV AC programmable test procedure

- › Prepare test setup as mentioned in IMPORTANT SAFETY NOTES above.
- › Select the **HV AC programmable** function.
- › Set test parameters / limits.
- › Connect HV test leads to HV terminals on the instrument.
- › Connect HV test leads to device under test.
- › Start measurement.

- › Measurement can be stopped manually or by timer.
- › Save results (optional).

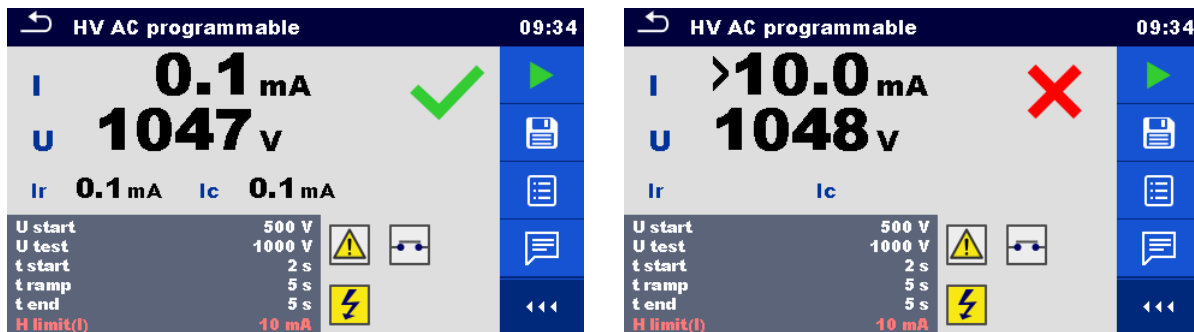

Figure 6.137: Examples of HV AC programmable test results

Note:

- › First HV measurement after power on the instrument (if password protection is enabled) or first HV measurement after enabling or changing password require entering password for enabling HV test. Refer to chapter 4.7.4 **Change password for HV functions** for more information.

6.2.40 Polarity

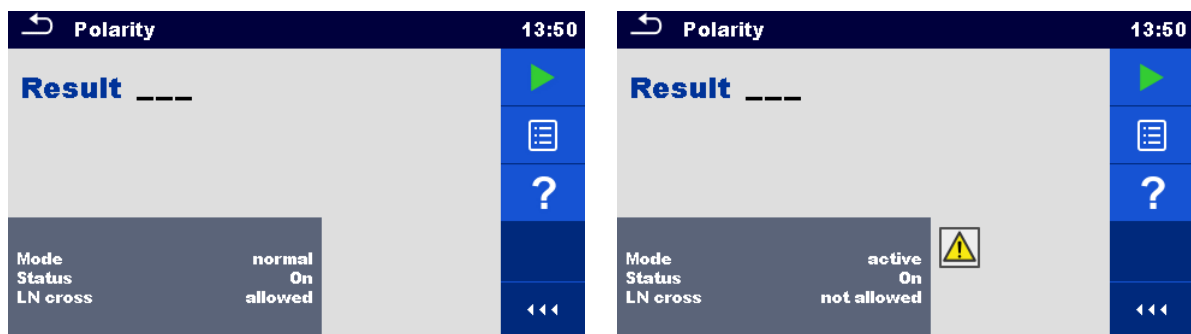

Figure 6.138: Polarity test menu

Test results / sub-results

Result.....Indication of the test [Pass, Description of the fault]

Test parameters

Mode	Test mode [normal, active]
Status	Test status [On, Off] (disable test status within Auto Sequence® for K/Di PRCD)
LN cross	L and N cross [not allowed, allowed] (phase and neutral change permission)
Wiring map¹⁾	Wiring map [standard, L1-L2-L3-N-PE, L2-L3-L1-N-PE, L3-L1-L2-N-PE, L3-L2-L1-N-PE, L2-L1-L3-N-PE, L1-L3-L2-N-PE, L1-L2-L3-PE, L2-L3-L1-PE, L3-L1-L2-PE, L3-L2-L1-PE, L2-L1-L3-PE, L1-L3-L2-PE, L1-N-PE, L2-N-PE, L3-N-PE, Rotation 123 (N), Rotation 321 (N), Rotation 123, Rotation 321]

¹⁾ Wiring map parameter replaces LN cross parameter if active polarity mode is selected and Metrel 3-phase adapter (A 1322 or A 1422) is connected.

Test circuits



Figure 6.139: Polarity test (manual)

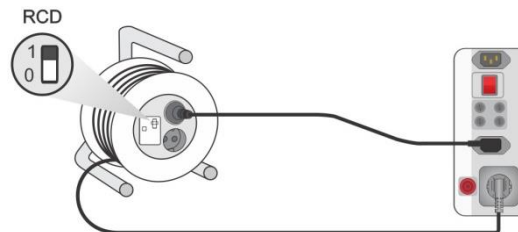

Figure 6.140: Polarity test (auto)

Polarity measurement procedure (mode = normal)

- › Select the **Polarity** function.
- › Set test parameters / limits (mode =normal)
- › Connect the cable to be tested to the instrument (see test circuits above).
- › Start measurement.
- › Save results (optional).

Polarity measurement procedure (mode = active)

- › Select the **Polarity** function.
- › Set test parameters / limits (mode =active)
- › Connect the (PRCD) cable to be tested to the instrument (see test circuits above).
- › Start measurement.
- › Switch ON the switch / PRCD within 8 s when prompted on the display.
- › Save results (optional).

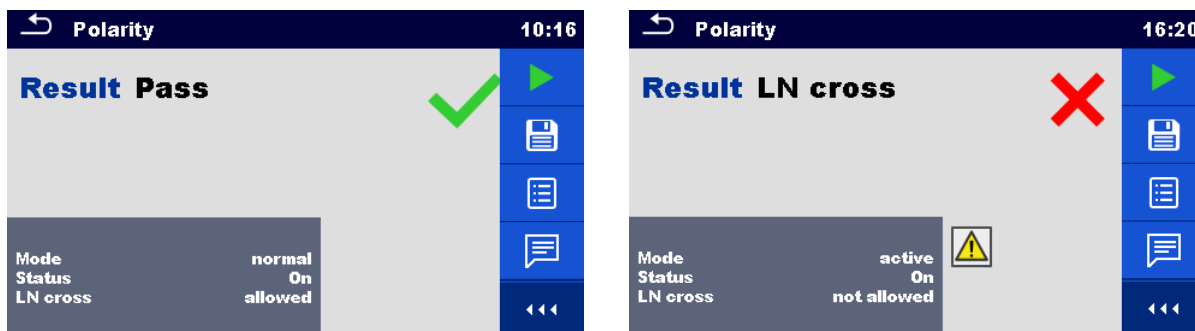

Figure 6.141: Examples of Polarity test

Note:

- › Active polarity test is intended for testing cords equipped with (P)RCD or mains operated switches.

6.2.41 Clamp current

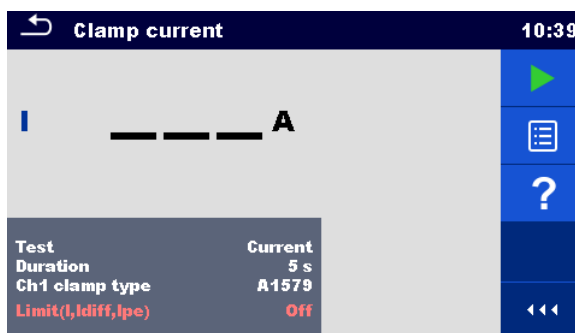

Figure 6.142: Clamp current test menu

Test results / sub-results

I Current

Test parameters

Test	Indication of measured clamp current [Differential leakage, PE leakage, Current]
Duration	Duration [Off, 2 s ... 180 s]
Ch1 clamp type	Current clamp model [A 1579]

Test limits

Limit(I,Idiff,Ipe)	High Limit (I, Idiff, Ipe) [Off, Custom, 0.25 mA ... 15.0 mA]
---------------------------	--

Test circuit

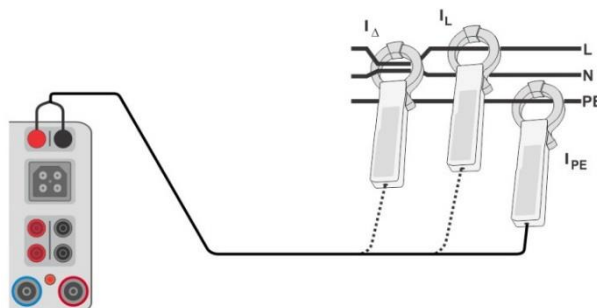

Figure 6.143: Clamp current test connections

Clamp current measurement procedure

- › Select the **Clamp current** function.
- › Set test parameters / limits.
- › Connect the current clamp to the instrument.
- › Embrace wire(s) that has to be measured with current clamp (see test circuits above).
- › Start measurement.
- › Measurement can be stopped manually or by timer.
- › Save results (optional).

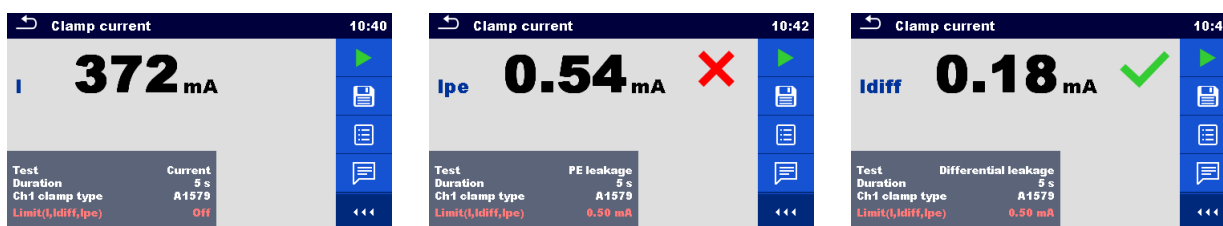

Figure 6.144: Examples of Current clamp measurement results

Note:

- The frequency range of this measurement is limited. This measurement cannot be used for measuring leakage currents of appliances, which are able to generate leakage currents with frequencies above 10 kHz or above the specified frequency range of the clamp.

6.2.42 No-load voltage (A 1422)

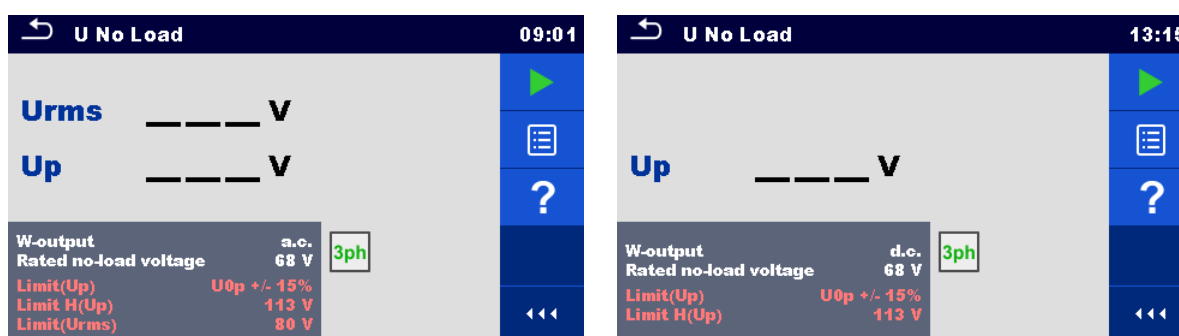

Figure 6.145: No-load voltage test menu

Test results / sub-results

Urms maximum no-load r.m.s a.c. value

Up maximum no-load peak a.c. / d.c. value

Test parameters

W-output	Voltage type on welding output [a.c., d.c.]
Rated no-load voltage	Rated U_0 no-load voltage [Custom, 20 V ... 99 V, -]

Test limits

Limit (Up)	Limit (Up) [$U_{op} \pm 15\%$]
Limit (Urms)	Maximum r.m.s a.c. output [Off, 48 V, 80 V, 100 V]
Limit H(Up)	Maximum peak a.c. output [Off, 68 V, 113 V, 141 V] Maximum d.c. output [Off, 113 V, 141 V]

Test circuit, No-load voltage measurement procedure

- Select the **U No Load** function.
- Set test parameters / limits.
- Connect METREL 3-phase adapter (A 1422) to the instrument*.
- Connect device under test to the 3-phase adapter*.
- Start measurement.
- Press  when the message **Ready** is displayed and wait for results.

- › Save results (optional).

*For more information refer to chapter *Measurements according to IEC/ EN 60974-4 – No load voltage in 3-phase adapter user manual.*

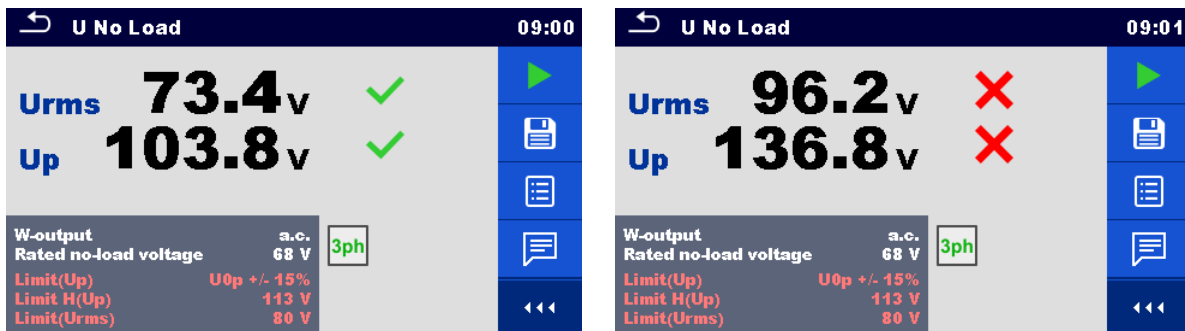

Figure 6.146: Examples of U No Load measurement results

Note:

- › This test is applicable only with connected METREL 3-phase adapter (A 1422).

6.2.43 Discharging time

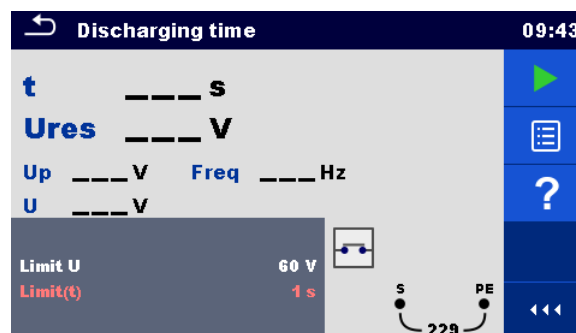

Figure 6.147: Discharging time measurement menu

Test results / sub-results

t	Discharging time
Ures	Residual voltage
Up	Peak value of supply voltage at disconnection time
U	RMS voltage
Freq	Frequency

Test limits

Limit U	Voltage limit [34 V, 60 V, 120 V]
Limit (t)	Time limit [1 s, 5 s]

Measuring principle

The measuring principle of the discharging time function is as following:

Phase 1:	The DUT is connected to the supply voltage via an external socket. The instrument monitors the voltage (on supply or internal connections) and internally stores the peak voltage, r.m.s. voltage and frequency values.
Phase 2:	The DUT is disconnected from the supply voltage and the voltage at the test terminals starts to fall. Once the r.m.s. voltage falls for 10 V the instrument

starts to measure discharging time.

Phase 3: After the voltage drops below an internally calculated voltage value, the timer is stopped. The instrument re-calculates the measured time and residual voltage to values as they would be, if the disconnection occurred at the maximum voltage value.

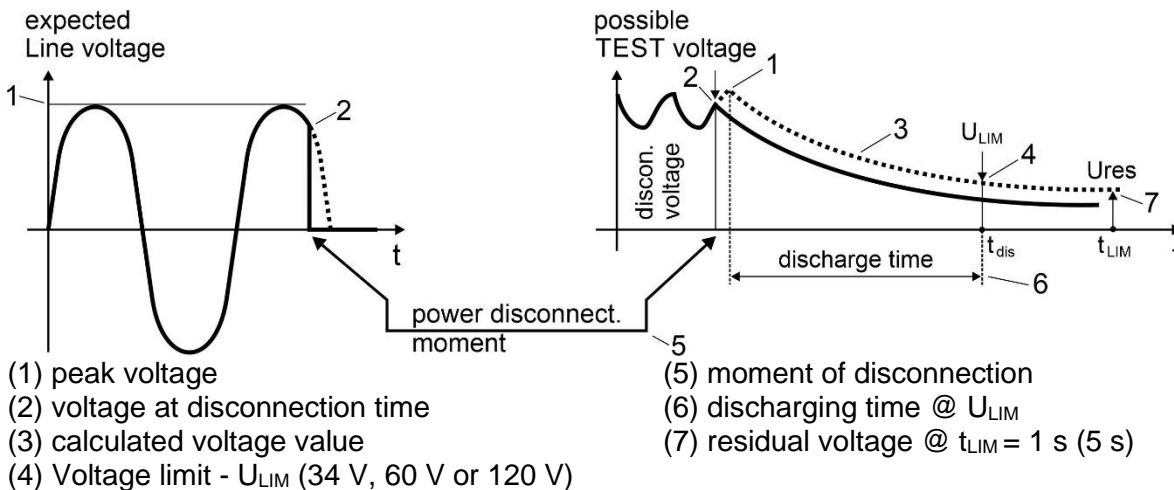

Figure 6.148: Discharging time measuring principle

Connection diagram

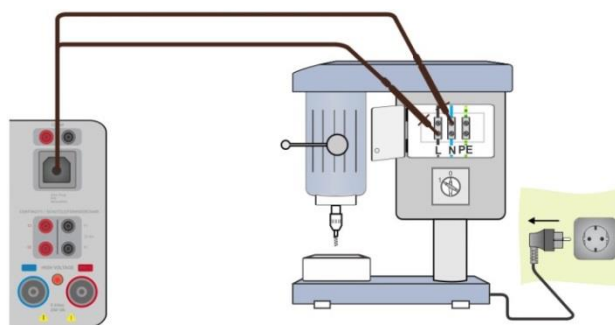

Figure 6.149: Discharging time measurement

Measurement procedure

- › Enter the **Discharging time** function.
- › Set test parameters / limits.
- › Connect Residual voltage cable to the instrument and to the device under test (DUT), see **Figure 6.149**.
- › Connect DUT to the mains supply and Switch it ON.
- › Start the measurement.
- › Measurement will stop automatically when disconnecting DUT from mains supply.
- › Save results (optional).

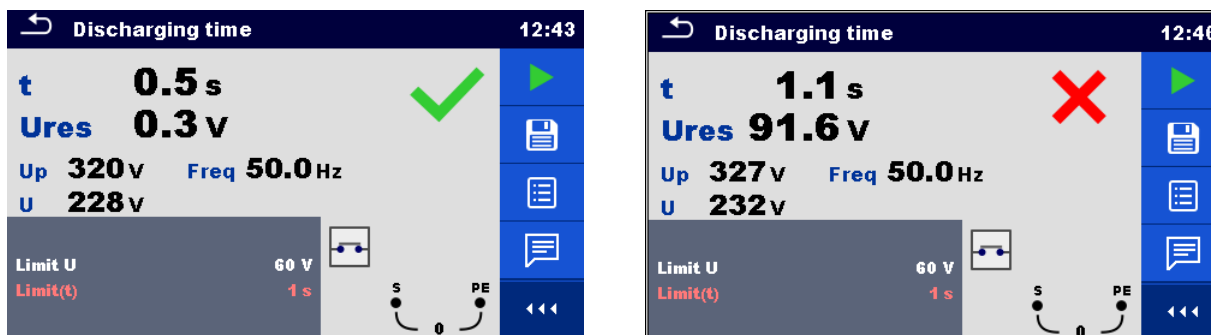

Figure 6.150: Discharging time test results

Note:

- › Interpretation of the 'Repeat' message:
It is not possible to differentiate between a disconnection moment at very low voltage and a machine with a very low discharging time. In both cases the reading will be 0.0 s together with the "Repeat" warning. If after few repetitions the result is always 0.0 s with the "Repeat" message it can be considered as a valid 0.0 s result. A 0.0 s reading without the "Repeat" message is a valid result.
- › Residual voltage is not displayed for DUTs with very low discharging time, or if detected disconnection voltage is lower than 20 V.

6.2.44 Measurements using adapter MD 9273

Clamp MD 9273 can be used as an adapter connected via Bluetooth® communication with MultiServicerXD in manner to expand its Power quality Test range. Supported test measurements and signal recordings are:

- P – Power CLAMP
- U – Voltage CLAMP
- I – Current CLAMP
- Imax – Inrush CLAMP
- h_n – Harmonics U CLAMP
- h_n – Harmonics I – CLAMP

Required test is selected from the CLAMP section of the Single Tests menu, see **Figure 6.151** below. Menu is available only when Adapter MD 9273 is set, see chapters **4.7.3 Settings** and **8.6 Communication with adapters** for details.

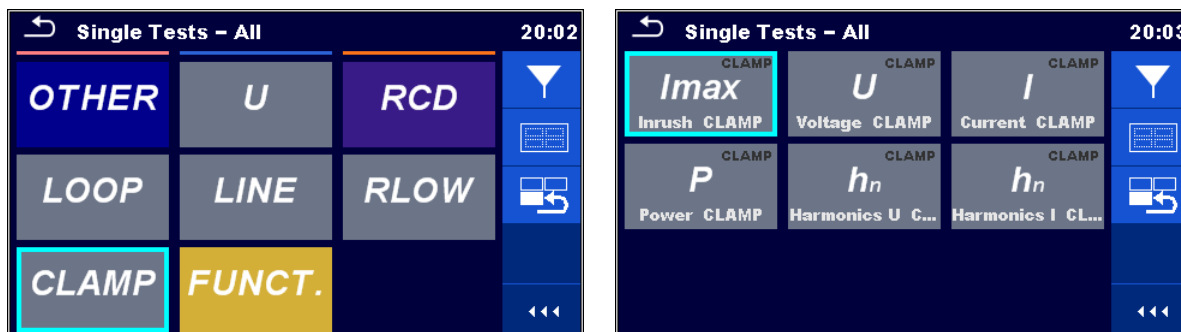

Figure 6.151: CLAMP single test selection menu

Selected test is configured from MultiServicerXD. Adapter MD 9273 acquires test signals, process measurements and send results to the MultiServicerXD. Results are presented on the instrument screen and can be saved to the Workspace memory for later use.

6.2.44.1 Power CLAMP

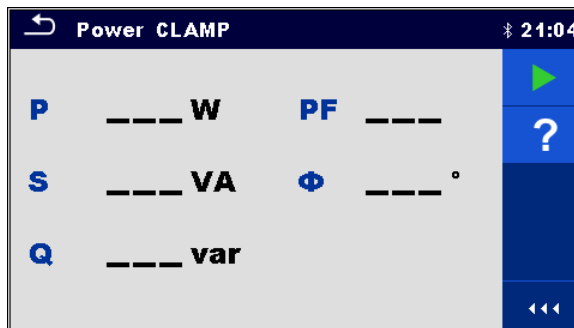

Figure 6.152: Power CLAMP menu

Test results / sub-results

P	Active power
S	Apparent power
Q	Reactive power (capacitive or inductive)
PF	Power factor (capacitive or inductive)
Φ	Phase displacement between voltage and current in degrees

Test parameters

There are no parameters to be set.

Test circuit

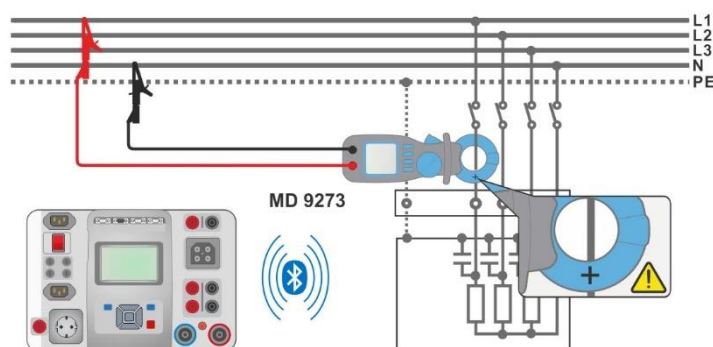

Figure 6.153: Power CLAMP connection

Measurement procedure

- › Connect MD 9273 to the item to be tested and set Bluetooth® mode.
- › Enter the **Power CLAMP** function and wait for active Bluetooth® communication sign.
- › Start the continuous measurement.
- › Stop the measurement.
- › Save results (optional).



Figure 6.154: Power CLAMP results

Note:

Voltage test terminals connection and current flow toward load should be taken into account; the red voltage terminal should be connected to the Line terminal and the jaw should be correctly oriented, to obtain positive sign of Power test result. If Power test result has negative sign, connection of voltage terminal or jaw orientation are opposite and the result of phase displacement angle has opposite sign too. Consequently, load character determination (capacitive or inductive) is mismatched.

6.2.44.2 Voltage CLAMP

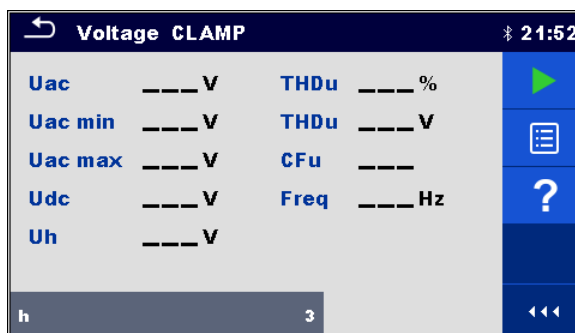

Figure 6.155: Voltage CLAMP menu

Test results / sub-results

Uac	Effective ac voltage value – last obtained result
Uac min	Minimum effective ac voltage value during measurement time duration
Uac max	Maximum effective ac voltage value during measurement time duration
Udc	DC voltage value
THDu [V]	Effective voltage value of all harmonics (without voltage value at fundamental frequency)
THDu [%]	Total harmonic distortion
Uh	Effective voltage value of set harmonic
CFu	Voltage Crest factor – peak voltage to effective ac voltage ratio
Freq	Fundamental frequency

Test parameters

h	Harmonic setup [1 to 19, 1 st is fundamental frequency]
----------	--

Test circuit

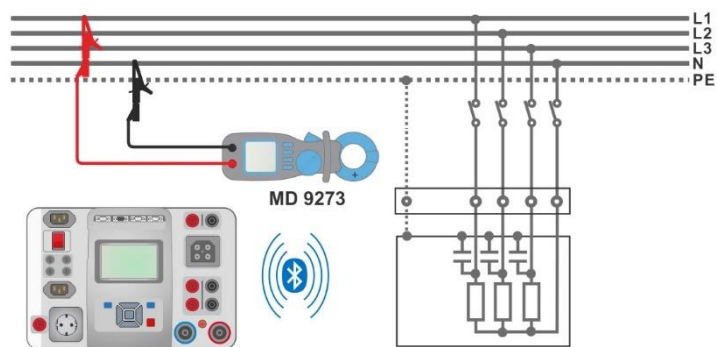

Figure 6.156: Voltage CLAMP connection

Measurement procedure

- › Connect MD 9273 to the item to be tested and set Bluetooth® mode.
- › Enter the **Voltage CLAMP** function and wait for active Bluetooth® communication sign.
- › Set test parameter.
- › Start the continuous measurement.
- › Stop the measurement.
- › Save results (optional).

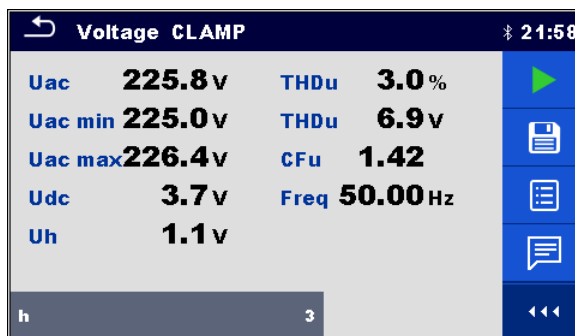

Figure 6.157: Voltage CLAMP results

6.2.44.3 Current CLAMP

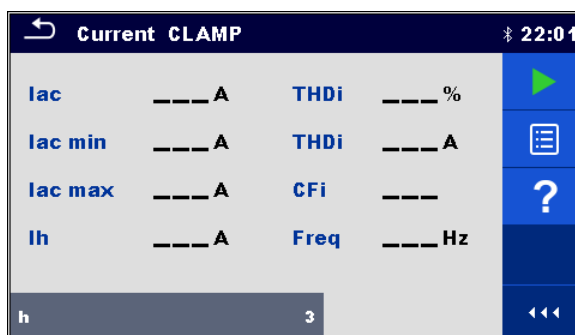

Figure 6.158: Current CLAMP menu

Test results / sub-results

Iac	Effective ac current value – last obtained result
Iac min	Minimum effective ac current value during measurement time duration
Iac max	Maximum effective ac current value during measurement time duration

THDi [A]	Effective current value of all harmonics (without current value at fundamental frequency)
THDi [%]	Total harmonic distortion
Ih	Effective current value of set harmonic
CFi	Current Crest factor – peak current to effective current ratio
Freq	Fundamental frequency

Test parameters

h Harmonic setup [1 to 19, 1st is fundamental frequency]

Test circuit

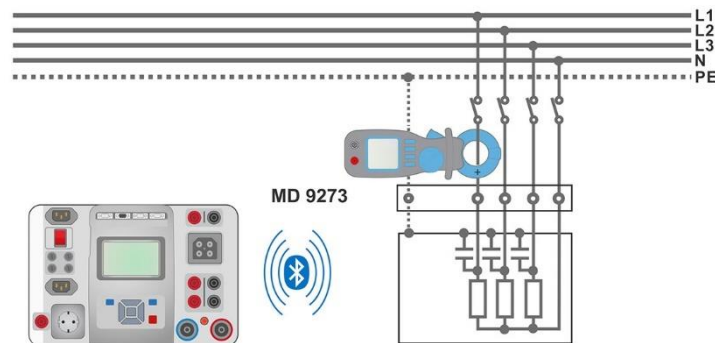

Figure 6.159: Current CLAMP connection

Measurement procedure

- › Connect MD 9273 to the item to be tested and set Bluetooth® mode.
- › Enter the **Current CLAMP** function and wait for active Bluetooth® communication sign.
- › Set test parameter.
- › Start the continuous measurement.
- › Stop the measurement.
- › Save results (optional).

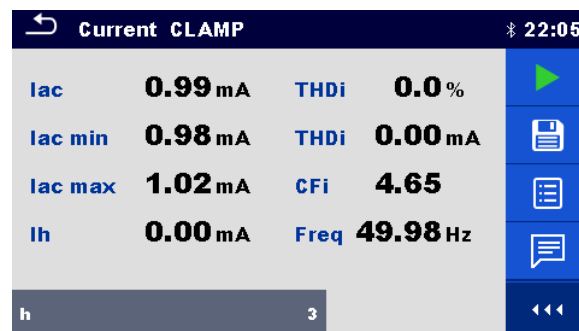



Figure 6.160: Current CLAMP results

6.2.44.4 Inrush CLAMP

Inrush CLAMP function records current and voltage transients that occur when load is turned on. Recorded values are presented on the screen of the instrument in separate charts. Two event triggers can be set, Voltage dip or Inrush current. Only one trigger can be active at the same time; when one is set, the other is switched off automatically. Voltage dip trigger is effective only if MD 9273 Voltage input is connected to supply circuit. Minimum effective circuit voltage is calculated during recorded transient and compared with set voltage threshold. Inrush

current trigger is effective only if the wire with flowing current is embraced with MD 9273 jaws. Maximum effective ac circuit current is calculated during recorded transient and compared with set Inrush threshold.

After Inrush Test is started, MD 9273 starts to record signals and waits for trigger event to occur, which is symbolised with sign  on the bottom right of the screen. Displayed chart is divided in Pre-trigger area, presenting first second of total set chart duration time and transient event area – rest of the chart duration time.

Trigger event occur automatically, when one of the recorder signals achieve set threshold level or can be initiated manually by tapping on the  icon within command menu on the right of the screen, see right screen picture of the figure below.

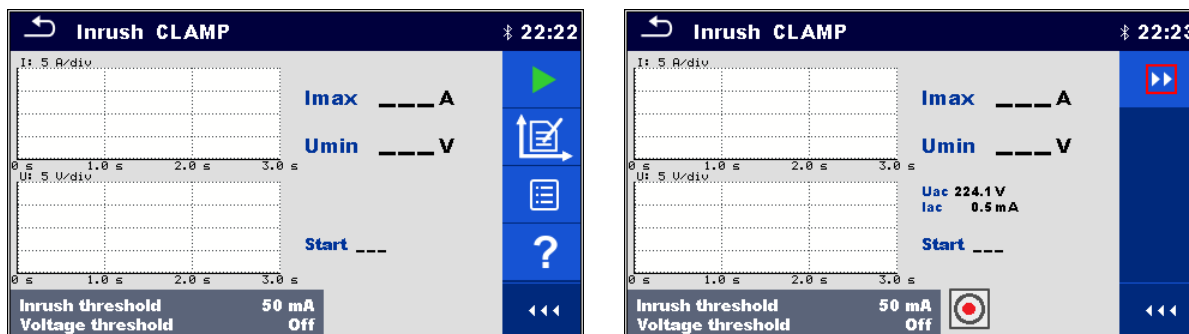

Figure 6.161: Inrush CLAMP menu – setup on the left, waiting for trigger on the right

Test results / sub-results

I:	Inrush current chart ¹⁾ range
	Recorded effective ac current value at cursor position
	Relative time of recorded data at cursor position
U:	Circuit voltage chart ¹⁾ range
	Recorded effective ac voltage value at cursor position
	Relative time of recorded data at cursor position
Imax	Inrush current maximum value of recorded data
Umin	Circuit voltage dip minimum value of recorded data
Uac	Effective ac voltage (within the measurement)
Iac	Effective ac current (within the measurement)
Start	Inrush test start recording time (from Master Instrument)

¹⁾ Tap on chart area or drag graph line cursor to present chart value at chosen time. Use left / right arrow keys for smooth setting.

Test parameters

Inrush threshold	Inrush current threshold setting [Off, 5 mA ... 90 A]
Voltage threshold	Voltage dip threshold setting [Off, 50 V ... 500 V]
Duration	Recording duration [3 s, 10 s]

Test circuit

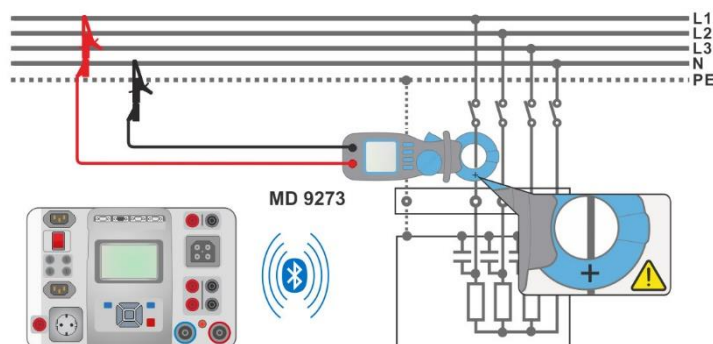

Figure 6.162: Inrush CLAMP connection

Test procedure

- › Connect MD 9273 to the item to be tested and set Bluetooth® mode.
- › Enter the **Inrush CLAMP** function and wait for active Bluetooth® communication sign.
- › Set test parameters.
- › Set charts Y value range²⁾ within expected values (optional; could be set later, after the test)
- › Start the test.
- › Initiate set threshold event or manually trigger test recording.
- › Save results (optional) after test is finished and results and recorded charts are presented on the screen.

²⁾ Chart range selection:

- › Voltage range [100 mV/div ... 100 V/div]
- › Current range [10 mA/div ... 200 A/div]

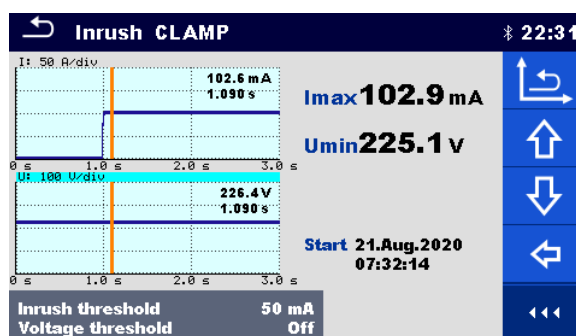

Figure 6.163: Inrush CLAMP results

6.2.44.5 Harmonics U CLAMP

Harmonics (1 through to 19) are measured and displayed in the chart as an absolute magnitude of the signal or as a percentage of the signal value at the fundamental frequency (the 1st harmonic h1). Absolute magnitude or percent value display is chosen by Type parameter setting.

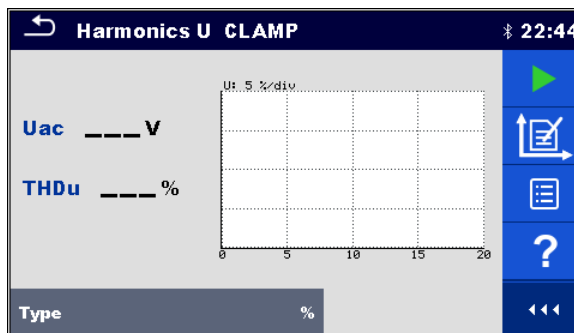

Figure 6.164: Harmonics U CLAMP menu

Test results / sub-results

U:	Harmonics chart range
Uac	Effective ac voltage value
THDu [%]	Total harmonic distortion
THDu [V]	Effective voltage value of all harmonics (without voltage value at fundamental frequency)
U:h5 [%]	Relative value of 5 th harmonic ³⁾
U:h5 [V]	Absolute voltage of 5 th harmonic ³⁾

³⁾ Tap on chart area at chosen harmonic to present its value.

Test parameters

Type	[%, V] % – harmonics and distortion are displayed as relative value V – harmonics and distortion are displayed as absolute value
-------------	--

Test circuit

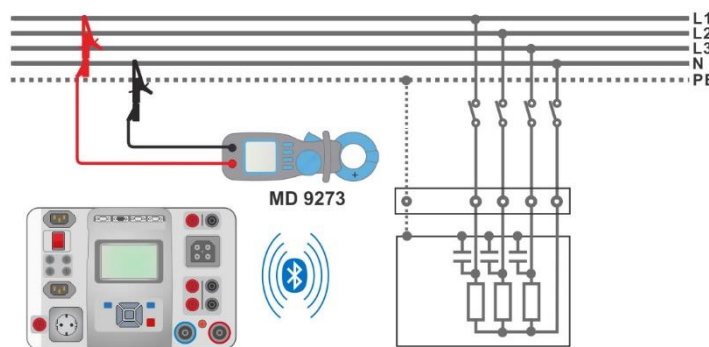

Figure 6.165: Harmonics U CLAMP connection

Measurement procedure

- ▶ Connect MD 9273 to the item to be tested and set Bluetooth® mode.
- ▶ Enter the **Harmonics U CLAMP** function and wait for active Bluetooth® communication.
- ▶ Set Type parameter.
- ▶ Set charts Y value range⁴⁾ within expected values (optional; could be set later, after the test).
- ▶ Start the continuous measurement.
- ▶ Stop the measurement.
- ▶ Save results (optional).

4) Chart Voltage range selection: [100 mV/div ... 100 V/div]

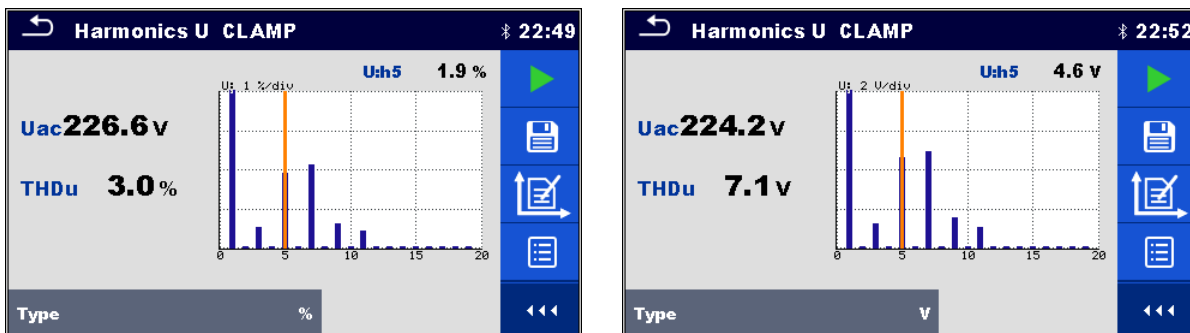

Figure 6.166: Harmonics U CLAMP results

6.2.44.6 Harmonics I CLAMP

Harmonics (1 through to 19) are measured and displayed in the chart as an absolute magnitude of the signal or as a percentage of the signal value at the fundamental frequency (the 1st harmonic h1). Absolute magnitude or percent value display is chosen by Type parameter setting.

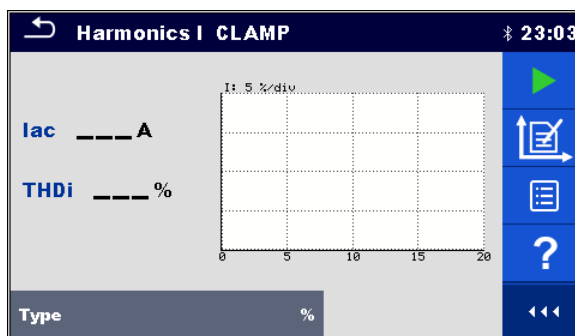

Figure 6.167: Harmonics I CLAMP menu

Test results / sub-results

I	Harmonics chart
Iac	Effective ac current value
THDi [%]	Total harmonic distortion
THDi [A]	Effective current value of all harmonics (without current value at fundamental frequency)
I:h3 [%]	Relative value of 3 rd harmonic ⁵⁾
I:h3 [A]	Absolute current value of 3 rd harmonic ⁵⁾

⁵⁾ Tap on chart area at chosen harmonic to present its value.

Test parameters

Type	[%, A] % – harmonics and distortion are displayed as relative value A – harmonics and distortion are displayed as absolute value
-------------	--

Test circuit

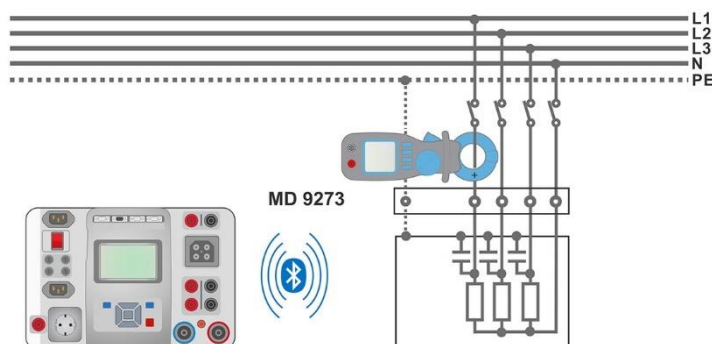

Figure 6.168: Harmonics I CLAMP connection

Measurement procedure

- › Connect MD 9273 to the item to be tested and set Bluetooth® mode.
- › Enter the **Harmonics I CLAMP** function and wait for active Bluetooth® communication.
- › Set Type parameter.
- › Set charts Y value range within expected values (optional; could be set later, after the test).
- › Start the continuous measurement.
- › Stop the measurement.
- › Save results (optional).

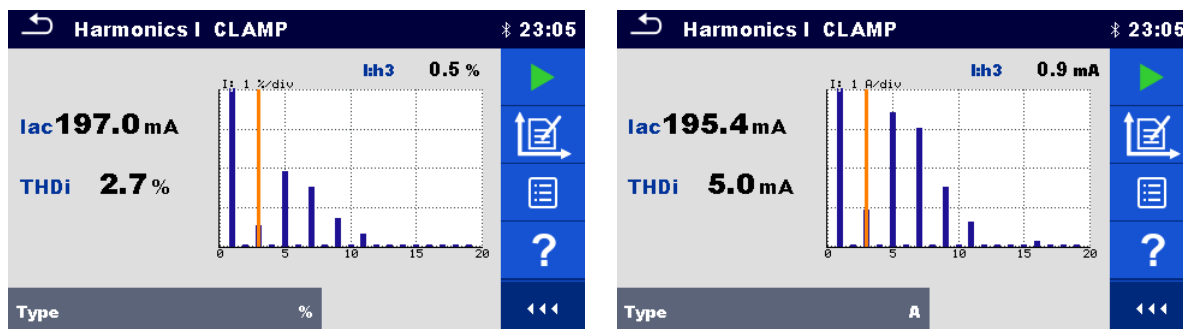

Figure 6.169: Harmonics I CLAMP results

6.2.45 Functional inspection

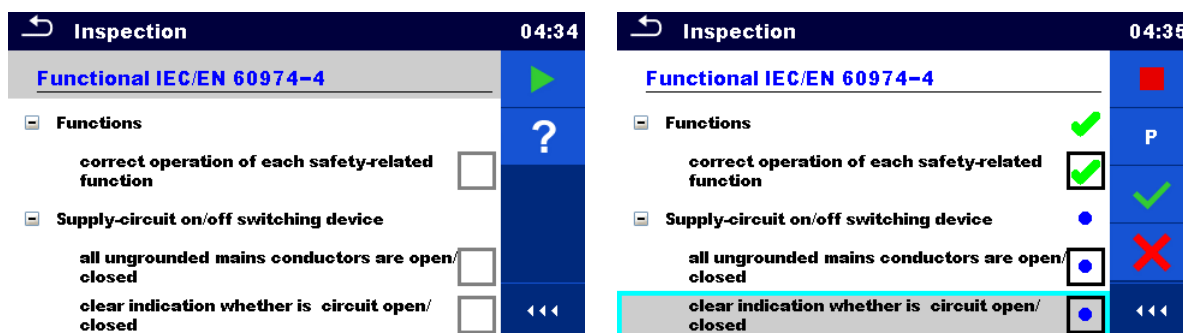

Figure 6.170: Functional inspection start menu (left) and menu during inspection (right)

Test parameters (optional)

For the optional Power measurement test, the parameters and limits are the same as set in the Power single test, see chapter **6.2.14 Power**.

Test circuit

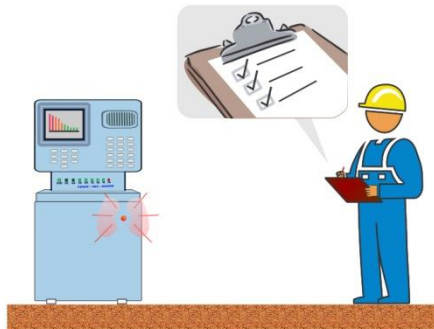

Figure 6.171: Functional inspection

Functional inspection procedure

- › Select the appropriate **Functional** inspection.
- › Start the inspection.
- › Power on the appliance through the mains test socket. Power measurement screen is displayed (optional).
- › Perform the functional inspection of the appliance / equipment.
- › Apply appropriate ticker(s) to items of inspection.
- › End the inspection.
- › Save results (optional).

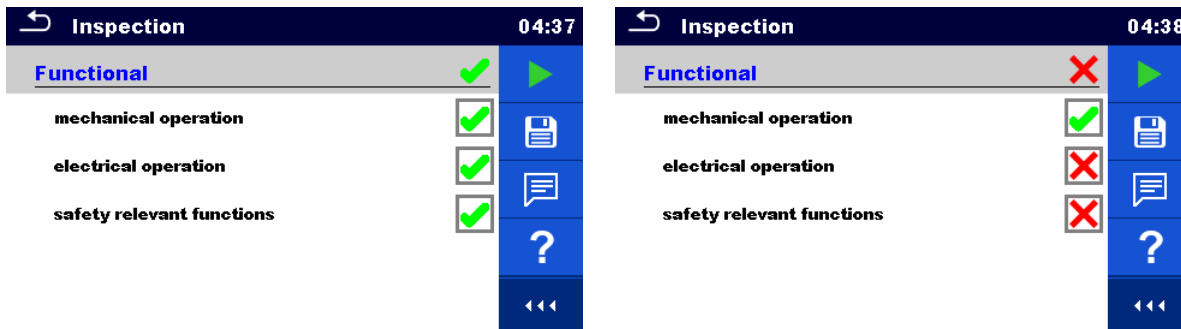

Figure 6.172: Examples of Functional Inspection results

7 Auto Sequences®

Pre-programmed sequences of measurements can be carried out in Auto Sequences® menu. The sequence of measurements, their parameters and flow of the sequence can be programmed. The results of an Auto Sequence® can be stored in the memory together with all related information.

Auto Sequences® can be pre-programmed on PC with the Metrel ES Manager software and uploaded to the instrument. Refer to chapter **Appendix E Programming of Auto Sequences® on Metrel ES Manager** for detailed information on programming Auto Sequences®.

On the instrument parameters and limits of individual single test in the Auto Sequence® can be changed / set.

7.1 Selection of Auto Sequence®

The Auto Sequence® list from Auto Sequence® groups menu should be selected first. Refer to chapter **4.12 Auto Sequence® groups** for more details.

7.1.1 Selecting an active Auto Sequence® group in Auto Sequences® menu

Auto Sequences® and Auto Sequence® group menus are interconnected so an active Auto Sequence® group can be selected also in the Auto Sequences® menu.

Procedure

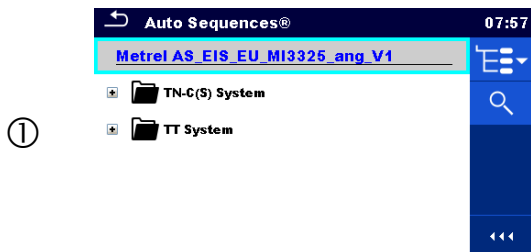

Tap on the active Auto Sequence® group header in Auto Sequences® Menu.



Opens a list of Auto Sequence® groups in Control panel.

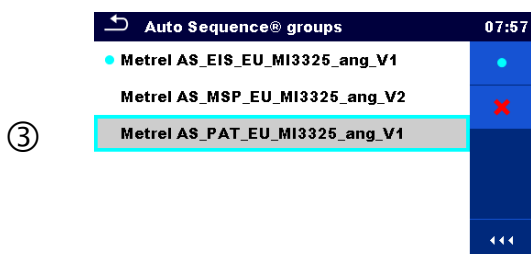

Select desired Auto Sequence® group from a list of groups.



Confirms a new selection.

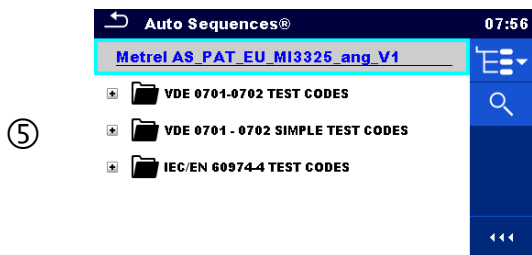

New Auto Sequence® group is selected and all Auto Sequences® within that group are displayed on the screen.

7.1.2 Searching in Auto Sequences® menu

In Auto Sequences® menu it is possible to search for Auto Sequences® on base of their Name or Short code.

Procedure

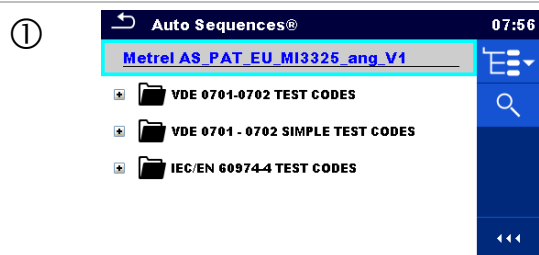

Search function is available from the active Auto Sequence® group header line.



Select Search in control panel to open Search setup menu.

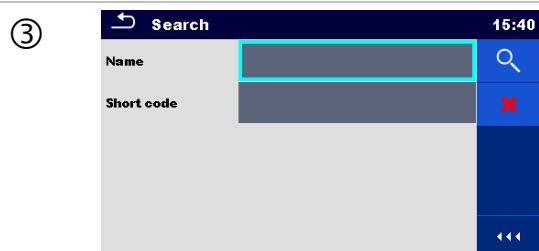

The parameters that can be searched for are displayed in the Search setup menu.

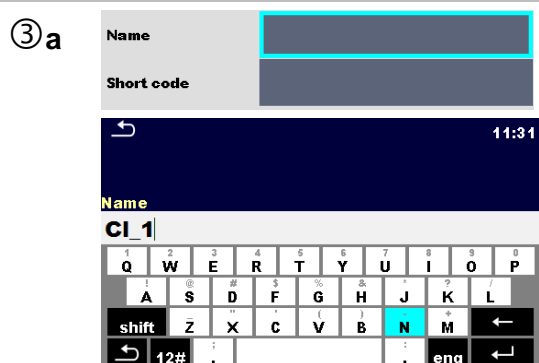

The search can be narrowed by entering a text in the Name and Short code fields.

Strings can be entered by using the on-screen keyboard.



Clears all filters. Sets filters to default value.



Searches through the active Auto Sequence® group according to the set filters. The results are shown in the Search results screen presented on **Figure 7.1**.

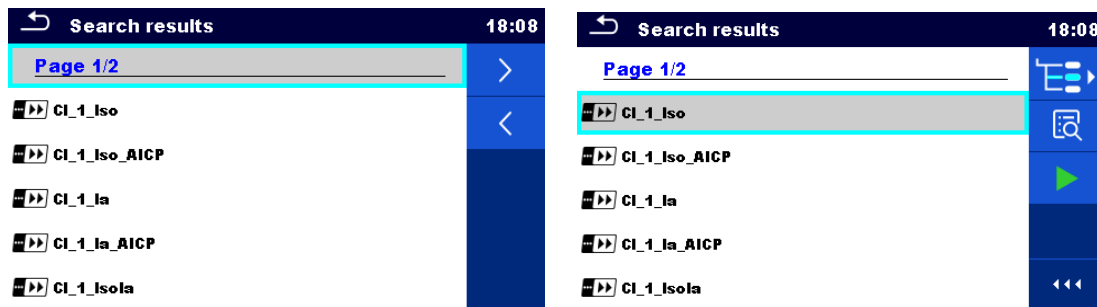







Figure 7.1: Search results screen – Page view (left), Auto Sequence® selected (right)

Options:

	Next page.
	Previous page.
	Goes to location in Auto Sequences® menu.
	Goes to Auto Sequence® view menu.
	Starts the selected Auto Sequence®.

Note:

Search result page consist of up to 50 results.

7.1.3 Organization of Auto Sequences® in Auto Sequences® menu

The Auto Sequences® to be carried out can be selected from the Main Auto Sequences® menu. This menu can be organized in a structural manner with folders, sub-folders and Auto Sequences®. Auto Sequence® in the structure can be the original Auto Sequence® or a shortcut to the original Auto Sequence®.

Auto Sequences® marked as shortcuts and the original auto Sequences® are coupled. Changing of parameters or limits in any of the coupled Auto Sequences® will influence on the original Auto Sequence® and all its shortcuts.

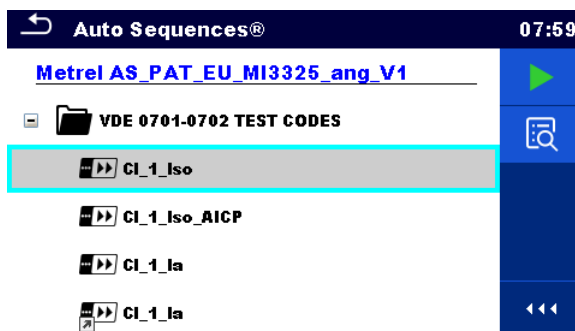







Figure 7.2: Examples of organized Auto Sequences® in main Auto Sequences® menu

Options:

 Cl_1_la	The original Auto Sequence®.
 Cl_1_la	A shortcut to the original Auto Sequence®.
	Starts the selected Auto Sequence®. The instrument immediately starts the Auto Sequence®.
	Enters menu for detailed view of selected Auto Sequence®. This option should also be used if the parameters / limits of the selected Auto Sequence® have to be changed. Refer to chapter 7.2.1 Auto Sequence® view menu for more information.
	Enters Auto Sequence® Configurator menu. See chapter 7.2.1.3 Auto Sequence® Configurator menu for details.

7.2 Organization of an Auto Sequence®

An Auto Sequence® is divided into three phases:

- Before starting the first test the Auto Sequence® view menu is shown (unless it was started directly from the Main Auto Sequences® menu). Parameters and limits of individual measurements can be set in this menu.
- During the execution phase of an Auto Sequence®, pre-programmed single tests are carried out. The sequence of single tests is controlled by pre-programmed flow commands.
- After the test sequence is finished the Auto Sequence® result menu is shown. Details of individual tests can be viewed and the results can be saved to Memory organizer.

7.2.1 Auto Sequence® view menu

In the Auto Sequence® view menu, the header and the single tests of selected Auto Sequence® are displayed. The header contains Name, Short code and description of the Auto Sequence®. Before starting the Auto Sequence®, test parameters / limits of individual measurements can be changed.

7.2.1.1 Auto Sequence® view menu (Header is selected)

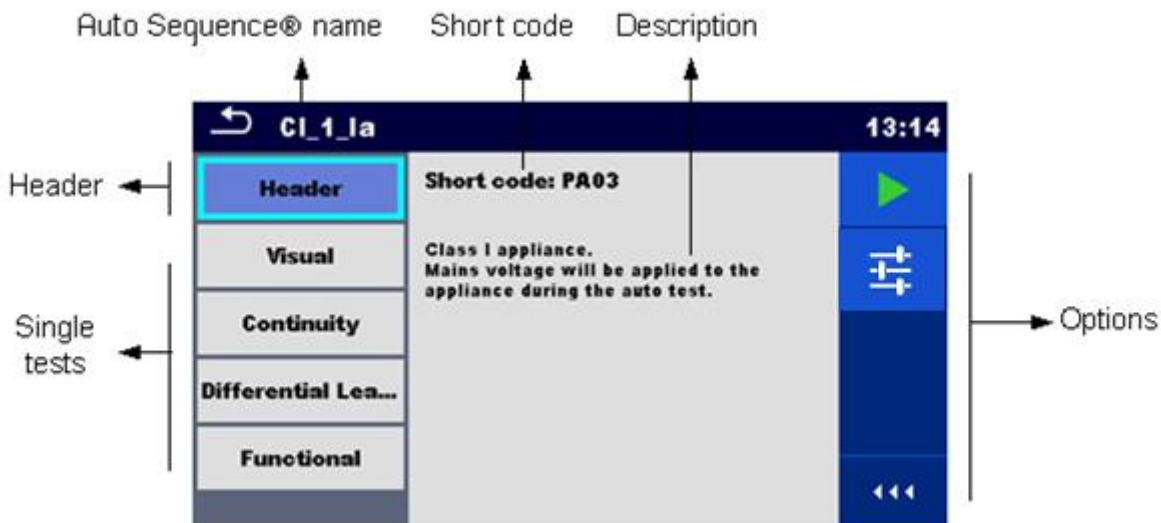

Figure 7.3: Auto Sequence® view menu – Header selected

Options:



Starts the Auto Sequence®.



Enters Auto Sequence® Configurator menu.
See chapter 7.2.1.3 Auto Sequence® Configurator menu for details.

7.2.1.2 Auto Sequence® view menu (measurement is selected)

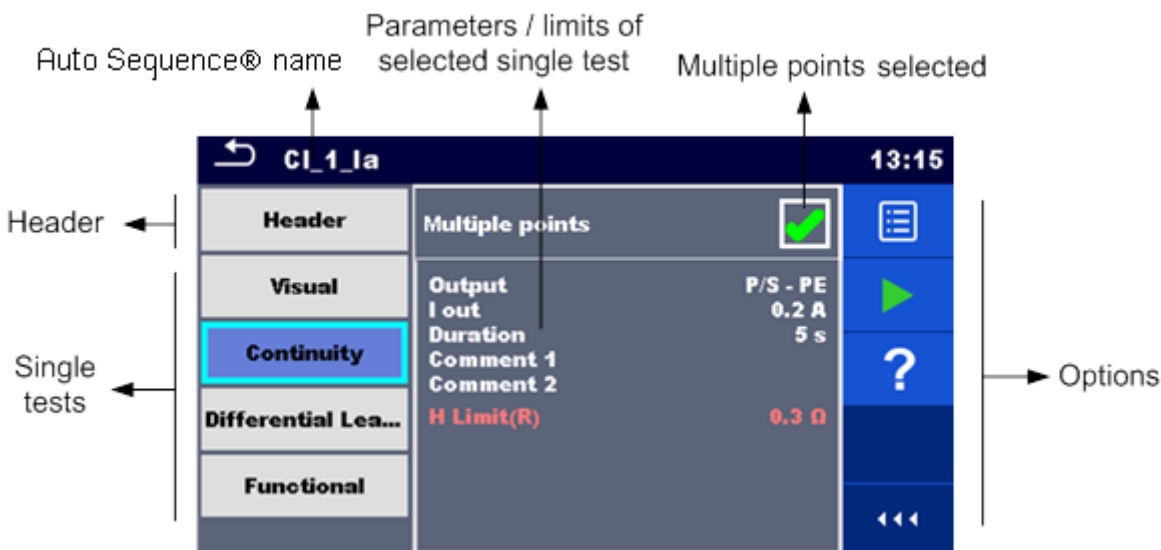

Figure 7.4: Auto Sequence® view menu – measurement is selected

Options



Selects single test measurement.



OR



on



Opens menu for changing parameters and limits of selected measurement.

Refer to chapter **6.1.1.2 Setting parameters, limits and comments of** single tests for more information.

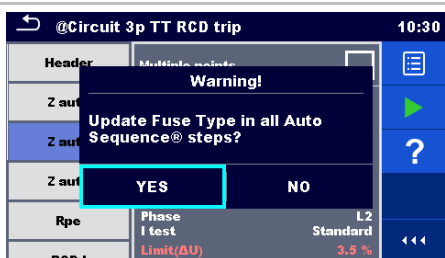

User must decide whether the changes in global parameter(s) apply to all single tests within the selected Auto Sequence® containing the modified parameter(s), or only for the edited one.



Starts the Auto Sequence®.



Opens help screens.
Refer to chapter **6.1.3 Help screens** for more information.



OR



on

Selects Multiple points.



OR



on



Sets operation mode for multiple points. For more information see chapter **7.2.1.5 Managing multiple points**.



7.2.1.3 Auto Sequence® Configurator menu

Auto Sequence® Configurator menu options are active only when single tests within selected Auto Sequence® contain configurable limits and / or parameters. They can be changed to suit requirements of current object under test before Auto Sequence® execution. Original settings are overwritten for intended Auto Sequence® execution only.

Select  Configurator option from Auto Sequence® Main screen or View screen to open Configurator menu presented on **Figure 7.5** below.

Available settings are organized in groups, each group starts with concerned Single test name. Limit Calculator is referred to Continuity or PE_conductor(PRCD) functions. Refer to Single test description chapter for details of parameters and limits setting / calculation.

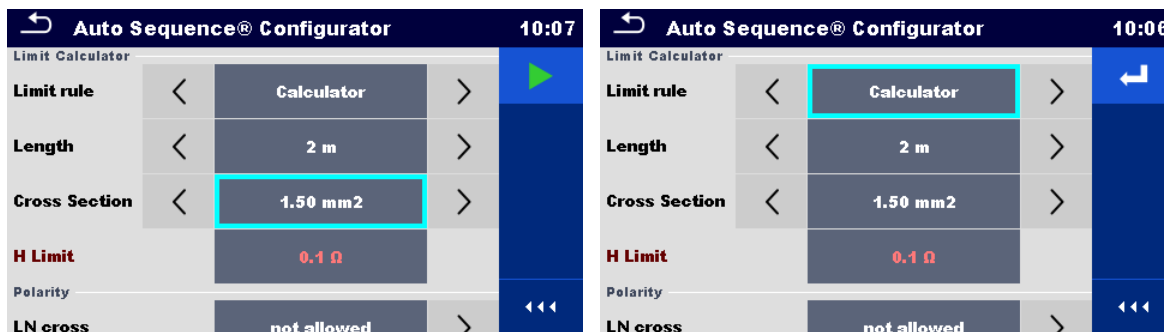

Figure 7.5: Auto Sequence® Configurator menu – opened from Auto Sequence® Main menu on the left, on the right opened from Auto Sequence® view menu

Options



Starts the Auto Sequence® from Configurator menu. Option is available, if configurator was opened from Auto Sequence® Main menu. New configuration is automatically applied to all related single tests.



Confirms limits and parameters setting and returns to view menu. Option is available, if configurator was opened from Auto Sequence® view menu. Start the Auto Sequence® from view menu with confirmed configuration.

7.2.1.4 Indication of Loops



The attached 'x3' at the end of single test name indicates that a loop of single tests is programmed. This means that the marked single test will be carried out as many times as the number behind the 'x' indicates. It is possible to exit the loop before, at the end of each individual measurement.

7.2.1.5 Managing multiple points

If the device under test has more than one test point for an individual single test and the selected Auto Sequence® predicts only one test point (one single test), it is possible to change the Auto Sequence® appropriately. Single tests with enabled Multiple points ticker will be executed in a continuous loop. It is possible to exit the loop anytime at the end of each individual measurement.

The Multiple points setting is valid only for the actual Auto Sequence®. If the user often tests appliances with more than one test point, it is recommended to programme a special Auto Sequence® with pre-programmed loops.

7.2.2 Step by step execution of Auto Sequences®

While the Auto Sequence® is running, it is controlled by pre-programmed flow commands. Examples of actions controlled by flow commands are:

- › pauses during the Auto Sequence®
- › buzzer Pass / Fail sound after the tests
- › pre-set data off appliances
- › expert mode for inspections
- › skip non-safety notifications
- › etc.

The actual list of flow commands is available on appendix *E.5 Description of flow commands*.

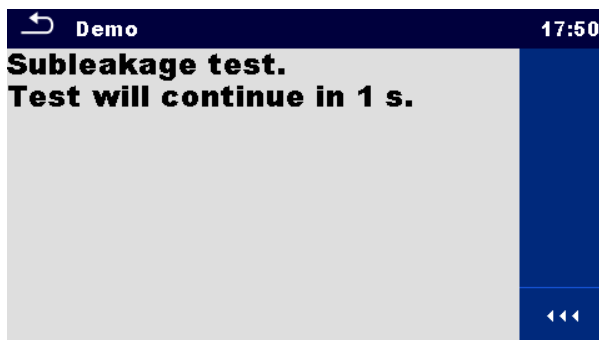

Figure 7.6: Auto Sequence® – Example of a pause with text message

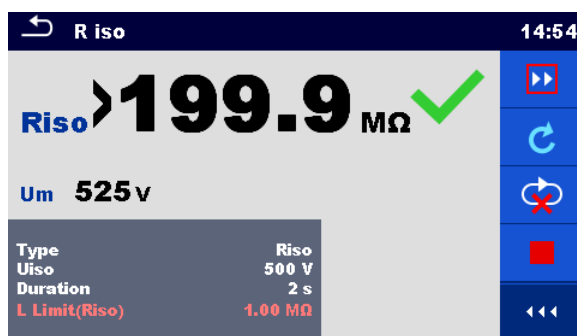





Figure 7.7: Auto Sequence® – Example of a finished measurement with options for proceeding

Options (during execution of an Auto Sequence®):

	Proceeds to next step in the test sequence.
	Repeats the measurement. Displayed result of a single test will not be stored.
	Ends the Auto Sequence® and goes to Auto Sequence® result screen. See chapter 7.2.3 Auto Sequence® result screen for more information.
	Exits the loop of single tests and proceeds to the next step in the Auto Sequence®.



Opens menu for viewing parameters and limits of a current measurement.



Adds comment.

The instrument opens keypad for entering a comment to a current measurement.

The offered options in the control panel depend on the selected single test, its result and the programmed test flow.

Notes:

- During Auto Sequences®, the popup Warning messages (see chapter 4.5 Symbols and messages) are displayed only before the first relevant single test within Auto Sequence®. This default setting can be changed with appropriate flow command. For more information about programming Auto Sequences® refer to Appendix E Programming of Auto Sequences® on Metrel ES Manager.
- If Inspection Expert mode flow command is set, the Visual inspection screen and Functional inspection screen are displayed for 1 second and an overall PASS is automatically applied at the end of test. In between, the automatic procedure can be stopped and statuses can be applied manually.

7.2.3 Auto Sequence® result screen

After the Auto Sequence® is finished the Auto Sequence® result screen is displayed. On the left side of the display the single tests and their statuses in the Auto Sequence® are shown.

In the middle of the display the header of the Auto Sequence® with Short code and description of the Auto Sequence® is displayed. At the top the overall Auto Sequence® result status is displayed. Refer to chapter 5.1.1 Measurement statuses for more information.

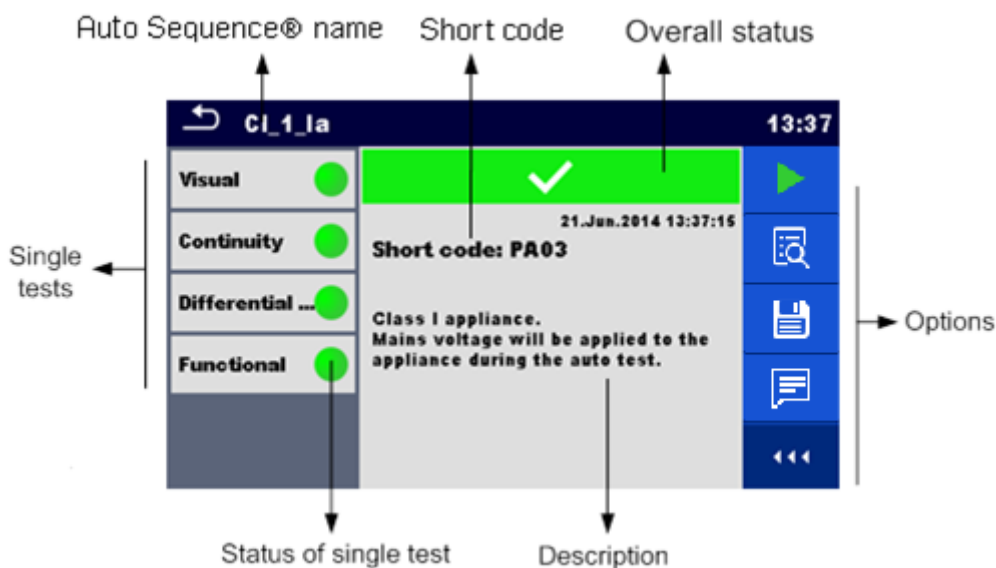

Figure 7.8: Auto Sequence® result screen

Options:

Starts a new Auto Sequence®.



View results of individual measurements.
The instrument goes to menu for viewing details of the Auto Sequence®, see **Figure 7.9** below.



Saves the Auto Sequence® results.

A new Auto Sequence® was selected and started from a Structure object in the structure tree:

- The Auto Sequence® result will be saved under the selected Structure object.

A new Auto Sequence® was started from the Auto Sequences® main menu:

- Saving under the last selected Structure object will be offered by default. The user can select another Structure object or create a new Structure object. By pressing  in Memory organizer menu the Auto Sequence® is saved under selected location.

An empty measurement was selected in structure tree and started:

- The result(s) will be added to the Auto Sequence®. The Auto Sequence® will change its overall status from 'empty' to 'finished'.

An already carried out Auto Sequence® test was selected in structure tree, viewed and then restarted:

- A new Auto Sequence® result will be saved under the selected Structure object.



Print label.



Print and Save Auto Sequence® results simultaneously.

Option is available if Devices parameter Auto save is set to On print, see chapter **4.9 Devices** for more information.



Write RFID / NFC tag. All data including Auto Sequence® results are written to the RFID/NFC writing device. Refer to **Appendix C Print labels and write / read RFID/NFC tags** for supported tag types.



Write RFID / NFC tag and Save Auto Sequence® results simultaneously. Option is available if Devices parameter Auto save is set to On write, see chapter **4.9 Devices** for more information.



Add comment.

The instrument opens keypad for entering a comment to Auto Sequence® result.

Note:

Options menu content depends on Devices settings menu. If no writing device is set, than 'Print label' and 'Write RFID' icons are hidden. Only one writing device can be set at the same time.

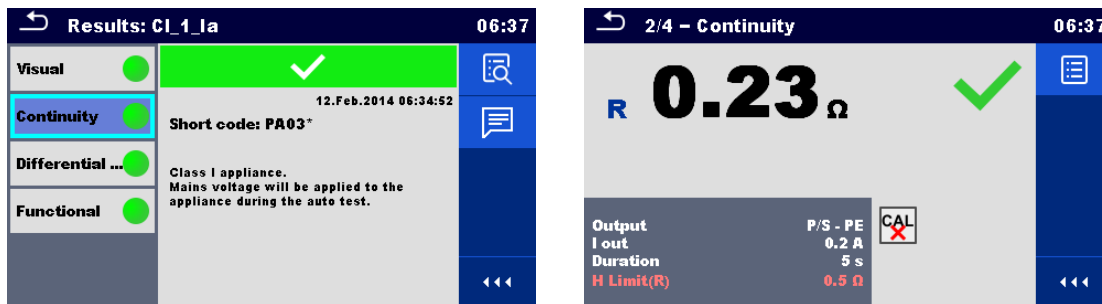

Figure 7.9: Menu for viewing details of Auto Sequence® and single test results

Options (menu for viewing details of Auto Sequence® and single test results):

	Details of selected single test in Auto Sequence® are displayed.
	View parameters and limits of selected single test.
	Add comment to selected single test results. View / edit comment to single test results, when recalled from memory.

7.2.4 Auto Sequence® memory screen

In Auto Sequence® memory screen details of the Auto Sequence® results can be viewed, labels can be printed, RFID/NFC tag can be written and a new empty Auto Sequence® can be started.

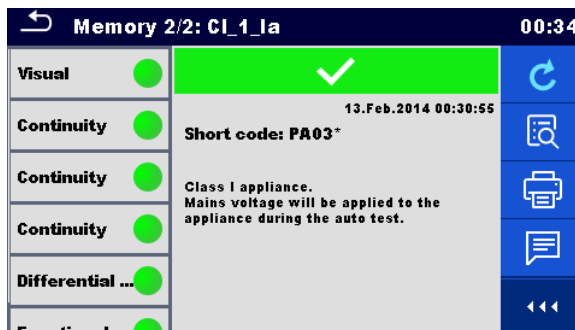

Figure 7.10: Auto Sequence® memory screen

Options

	Retest the Auto Sequence®. Enters menu for a new empty Auto Sequence®.
	Enters menu for viewing details of the Auto Sequence® results. See chapter 7.2.3 Auto Sequence® result screen for more information.
	View / edit Auto Sequence® comment.



Print label.



Write RFID/NFC tag. Data are written to the RFID/NFC tag. Refer to **Appendix C Print labels and write / read RFID/NFC tags** for supported tag types.

Note:

Options menu content depends on Devices settings menu. If no writing device is set, than 'Print label' and 'Write RFID' icons are hidden. Only one writing device can be set at the same time.

8 Communications

The instrument can communicate with the Metrel ES Manager PC software. The following action is supported:

- › Saved results and Tree structure from Memory organizer can be downloaded and stored to a PC.
- › Tree structure and Auto Sequences® from Metrel ES Manager PC software can be uploaded to the instrument.

Metrel ES Manager is a PC software running on Windows 8.1, Windows 10 and Windows 11. There are three communication interfaces available on the instrument: RS-232, USB and Bluetooth. Instrument can also communicate to various external devices (android devices, test adapters, scanners, printers,...).

8.1 USB and RS232 communication with PC

The instrument automatically selects the communication mode according to detected interface. USB interface has priority.

How to establish an USB or RS-232 link:

- › RS-232 communication: connect a PC COM port to the instrument RS232-1 (PC) connector using the RS232 serial communication cable;
- › USB communication: connect a PC USB port to the instrument USB connector using the USB interface cable.
- › Switch on the PC and the instrument.
- › Run the *Metrel ES Manager* software.
- › Select communication port (COM port for USB communication is identified as "Measurement Instrument USB VCom Port").
- › The instrument is prepared to communicate with the PC.

8.2 Bluetooth communication

The internal Bluetooth module enables easy communication via Bluetooth with PC and Android devices.

How to configure a Bluetooth link between instrument and PC

- › Switch On the instrument.
- › On PC configure a Standard Serial Port to enable communication over Bluetooth link between instrument and PC. Usually, no code for pairing the devices is needed.
- › Run the *Metrel ES Manager* software.
- › Select configured communication port.
- › The instrument is prepared to communicate with the PC.

How to configure a Bluetooth link between instrument and Android device

- › Switch On the instrument.
- › Some Android applications automatically carry out the setup of a Bluetooth connection. It is preferred to use this option if it exists. This option is supported by Metrel's Android applications.

-
- › If this option is not supported by the selected Android application, then configure a Bluetooth link via Android device's Bluetooth configuration tool. Usually, no code for pairing the devices is needed.
-
- › The instrument and Android device are ready to communicate.
-

Notes

- › Sometimes there will be a demand from the PC or Android device to enter the code. Enter code '1234' to correctly configure the Bluetooth link.
- › The name of correctly configured Bluetooth device must consist of the instrument type plus serial number, e.g. *MI 3325-12240429I*. If the Bluetooth module got another name, the configuration must be repeated.
- › In case of serious troubles with the Bluetooth communication it is possible to reinitialize the internal Bluetooth module. The initialization is carried out during the Initial settings procedure. In case of a successful initialization "INITIALIZING... OK!" is displayed at the end of the procedure. See chapter **4.7.6 Initial Settings**.
- › Check if there are available Metrel Android applications for this instrument.

8.3 Bluetooth communication with printers and scanners

MultiServicerXD instrument can communicate with supported Bluetooth printers and scanners. Contact Metrel or your distributor which external devices and functionalities are supported. See Chapter **4.9 Devices** for details how to set the external Bluetooth devices.

8.4 RS232 communication with other external devices

It is possible to communicate with scanners via the RS232-1 serial port and printers via the RS232-2 (PC) serial port. Contact Metrel or your distributor which external devices and functionalities are supported.

8.5 Ethernet communication

The instrument is also capable of communicating through an Ethernet port. The Ethernet communication must be fully configured in the setting menu before first use. See chapter **4.7.3 Settings** for details.

Metrel ES Manager is currently **not** supporting Ethernet communication. Contact Metrel or your distributor regarding options for using the Ethernet communication.

8.6 Communication with adapters

MultiServicerXD can communicate with Metrel test and measurement adapters through wired RS232 port or wireless Bluetooth communication port.

Adapter can be selected from the list of adapters from *General Settings / Settings / Adapters section* menu, see **Figure 8.1** below.

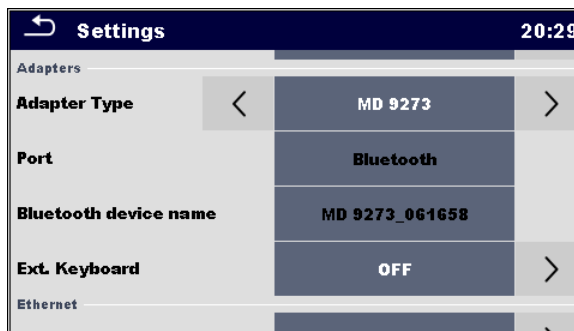



Figure 8.1: Adapters section menu

When adapter is selected from the list, supported communication port is automatically offered. To establish Bluetooth communication, adapter must be paired with MultiServicerXD

Procedure:

1. **Adapter:** switch it ON and select BT mode, if not already automatically selected.
2. **MultiServicerXD:** Open General Settings / Settings menu and navigate to the Adapters section.
3. **Adapter type:** select adapter by using left / right arrows or tap on the field and select it from the list of adapters
4. **Port:** Bluetooth or RS232, which one is supported by the adapter, is automatically offered. Connect serial cable or proceed with pairing procedure
5. **Bluetooth device name:** select field and instrument start searching for Bluetooth devices; when finished, list of available devices is presented on the screen
6. **Select Adapter name from the list:** pairing procedure is finished.

When test supported by the adapter is selected on MultiServicerXD, active BT communication is indicated with sign  on the right – top of the screen.

Note:

Pairing between same Metrel adapter and same MultiServicerXD is necessary only when adapter is first time used. If communication is not established when supported test is selected, adapter is probably switched OFF or Bluetooth link is out of range.

8.7 Connections to test adapters

8.7.1 Active 3 Phase Adapter /Plus (A 1322 / A 1422)

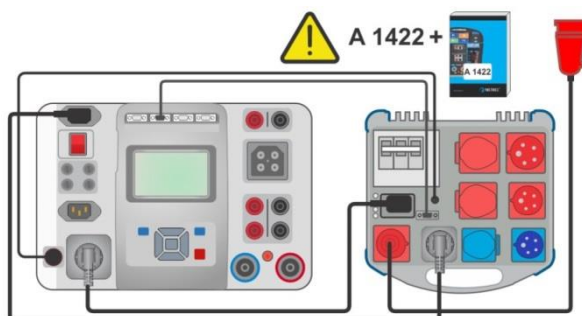

Figure 8.2: Connection of Active 3 Phase Adapter / plus (A 1322 / A 1422)

Note:

- See 3-phase adapter A 1322 / A 1422 user manual for more details.

8.7.2 Euro Z 290A adapter A 1143

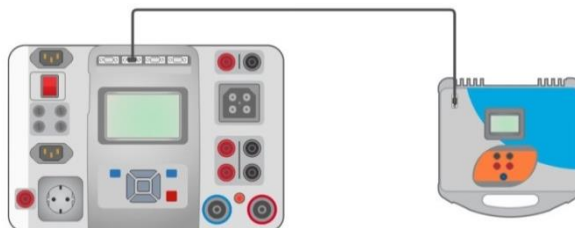

Figure 8.3: Connection of the Euro Z 290 A adapter A 1143

Note:

- See Euro Z 290 A adapter user manual for more details.

8.7.3 Euro Z 440 V / 800 V instrument (MI 3143, MI 3144)

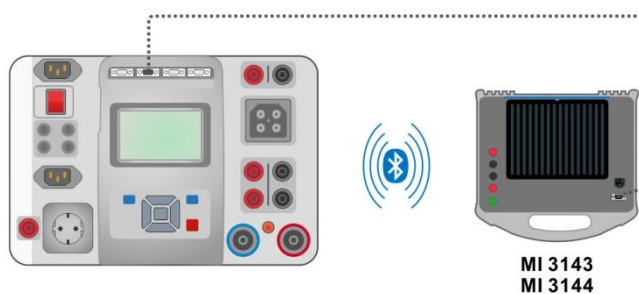

Figure 8.4: Connection of the Euro Z 440 V / 800 V instrument (MI 3143, MI 3144)

Note:

- See Euro Z 440 V / 800 V instrument user manuals for more details.

8.7.4 eMobility Analyser (A 1632)



Figure 8.5: Connection of the eMobility Analyser (A 1632)

Note:

- See eMobility Analyser A 1632 user manual for more details.

8.7.5 Leakage clamp meter with Bluetooth® communication (MD 9273)



Figure 8.6: Connection of Leakage clamp meter with Bluetooth® communication

Note:

- See Leakage clamp meter with Bluetooth® communication MD 9273 user manual for more details.

8.7.6 CE Adapter A 1460

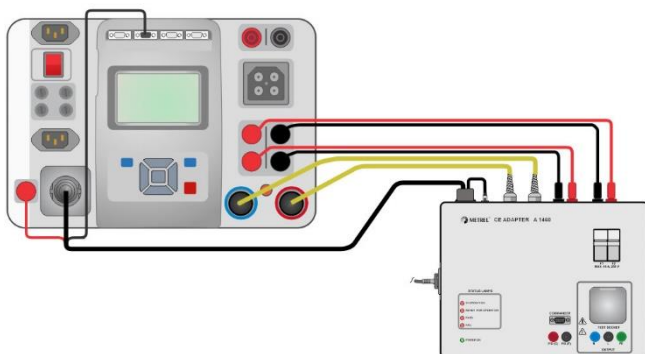

Figure 8.7: Connection of CE Adapter A 1460 to the instrument

Note:

- See CE Adapter A 1460 user manual for more details.

8.8 INPUTS

The DB9 connector INPUTS is intended for connection of external control signals.

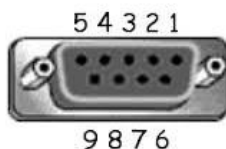

Figure 8.8: INPUTS connector - pin layout

Legend:

Pin	Description	Type
5	EXTERNAL OK Input for Remote control	Input low: < 1 V d.c. against earth

	KEY mode	pedal	Input high: > 4.5 V d.c. against earth Umax: 24 V a.c, d.c. against earth
6	IN_2	External input 2	
7	IN_3	External input 3	
8	IN_4	External input 4	
4	IN_5	External input 5	
9		GND	
3		Instrument reset pin	
1,2		Not supported	

8.9 OUTPUTS

Via the DB9 connector OUTPUTS, 4 - control signals for external devices are provided.

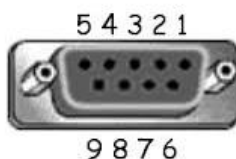
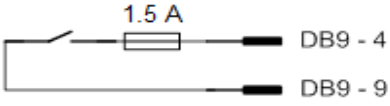





Figure 8.9: OUTPUTS connector - pin layout

Legend:

Pin			Description	Type
4,9		OUT_1	Control output 1	NO relay, Umax: 24V, Imax: 1.5 A Output low: open contact Output high: closed contact
3,8		OUT_2	Control output 2	
2,7		OUT_3	Control output 3	
1,6		OUT_4	Control output 4	
5		+5 V	Supply for inputs	

8.9.1 Warning lamps

Instruments supports HV warning lamps and Pass / Fail status lamps in single tests (refer to parameter “Warning lamps” setting in chapter 4.7.3 Settings), and in Auto Sequences®, by using flow commands (refer to appendix E.3.3 Flow commands for details). Instrument currently supports A 1496 and A 1497 Warning lamps adapters. See manuals of individual adapters for details on connections and operation.

9 Upgrading the instrument

The instrument can be upgraded from a PC via the RS232-1(PC) or USB communication port. This enables to keep the instrument up to date even if the standards or regulations change. The firmware upgrade requires internet access and can be carried out from the **Metrel ES Manager** software with a help of special upgrading software – **FlashMe** which will guide you through the upgrading procedure. For more information refer to Metrel ES Manager Help file.

10 Maintenance

10.1 Periodic calibration

It is essential that all measuring instruments are regularly calibrated in order for the technical specification listed in this manual to be guaranteed. We recommend an annual calibration.

10.2 Fuses

There are four fuses on the front panel:

F1, F2: F 3.15 A / 250 V / (20 × 5) mm / 1500 A: intended for instrument protection.

F3, F4: T 16 A / 250 V / (32 × 6,3) mm / 1500 A: protection against over-currents through mains test socket.

For position of fuses refer to chapter **3.1 Front panel**.

Warnings!

- › **Switch off the instrument and disconnect all test accessories and mains cord before replacing the fuses.**
- › **Replace blown fuses with the same type as defined in this document.**

10.3 Service

For repairs under or out of warranty please contact your distributor for further information.

Unauthorized person is not allowed to open the MultiServicerXD instrument. There are no user replaceable parts inside the instrument.

10.4 Cleaning

Use a soft, slightly moistened cloth with soap water or alcohol to clean the surface of MultiServicerXD instrument. Leave the instrument to dry totally before using it.

Notes:

- › Do not use liquids based on petrol or hydrocarbons!
- › Do not spill cleaning liquid over the instrument!

11 Technical specifications

11.1 HV AC, HV AC programmable

Voltage a.c.

	Range	Resolution	Accuracy
U	0 V ... 1999 V	1 V	±(3 % of reading)
	2.00 kV ... 5.99 kV	10 V	±(3 % of reading)

Current a.c. (apparent)

	Range	Resolution	Accuracy
I	0.0 mA ... 49.9 mA** / 99.9 mA*	0.1 mA	±(3 % of reading + 3 D)

Current a.c.(capacitive, resistive)

	Range	Resolution	Accuracy
I _r	0.0 mA ... 49.9 mA** / 99.9 mA*	0.1 mA	Indicative
I _c	-49.9 mA ... 49.9 mA** -99.9 mA ... 99.9 mA*	0.1 mA	Indicative

* Output voltage 100 V ... 2700 V

** Output voltage 2710 V ... 5100 V

Output voltage 100 V ... 1000 V (-0/+10%),
 1010 V ... 5100 V (-0/+5%) floating to earth
 Trip out time (if apparent current exceeds high limit)..... < 30 ms
 Short circuit current > 200 mA
 Output power.....250 VA max.

Test terminals:

All results	HV terminals
-------------	--------------

11.2 Continuity

Continuity resistance

	Range	Resolution	Accuracy
R	0.00 Ω ... 19.99 Ω	0.01 Ω	±(2 % of reading + 2 D)
	20.0 Ω ... 99.9 Ω	0.1 Ω	± 3 % of reading
	100.0 Ω ... 199.9 Ω	0.1 Ω	± 5 % of reading
	200 Ω ... 999 Ω	1 Ω	indicative

Voltage drop (I_{out} = 10 A)

	Range	Resolution	Accuracy
ΔU	0.00 V ... 19.99 V	0.01 V	±(2 % of reading + 5 D)
	20.0 V ... 99.9 V	0.1 V	± 3 % of reading

Limit value of voltage drop versus wire cross-section:

Wire cross-section (mm ²)	Limit voltage drop (V)
0.5	5.0

0.75	5.0
1	3.3
1.5	2.6
2.5	1.9
4	1.4
≥6	1.0

Operating range (acc. to EN 61557-4) 0.08 Ω ... 199.9 Ω
 Test currents 0.2 A, 4 A, 10 A, 25 A
 Current source (at nominal mains voltage, use of standard accessories)
 > 0.2 A at R < 8 Ω
 > 4 A at R < 1 Ω
 > 10 A at R < 0.5 Ω
 > 25 A at R < 0.2 Ω
 Open circuit voltage < 6 V a.c.
 Test lead compensation up to 5 Ω
 Max. R compensation custom value up to 2 Ω

Test terminals:

All results	P/S – Socket PE, Socket PE – IEC PE, C1P1 – C2P2
-------------	--

11.3 Insulation Resistance RPAT (RISO, RISO-S)

Insulation resistance, Insulation resistance –S (250 V, 500 V)

	Range	Resolution	Accuracy
Riso Riso-S	0.08 MΩ ... 19.99 MΩ	0.01 MΩ	±(3 % of reading + 2 D)
	20.0 MΩ ... 99.9 MΩ	0.1 MΩ	± 5 % of reading
	100.0 MΩ ... 199.9 MΩ	0.1 MΩ	± 10 % of reading

Output voltage

	Range	Resolution	Accuracy
Um	0 V ... 600 V	1 V	±(3 % of reading + 2 D)

Operating range (acc. to EN 61557-2) 0.08 MΩ ... 199.9 MΩ
 Nominal voltages Un 250 V, 500 V (- 0 %, + 10 %)
 Short circuit current max. 2.0 mA

Test terminals:

Riso	Socket LN – Socket PE, P/S
Riso-S	Socket LN – P/S

11.4 Sub-Leakage Current, Substitute Leakage Current - S

Substitute leakage current, Substitute leakage current - S

	Range	Resolution	Accuracy
Isub	0.02 mA ... 1.99 mA	0.01 mA	±(3 % of reading + 3 D)
Isub-S	2.00 mA ... 19.99 mA	0.01 mA	±(5 % of reading)

Operating range (acc. to EN 61557-16) 0.02 mA ... 19.99 mA
 Open circuit voltage 230 V a.c., 110 V a.c.
 Current calculated to mains supply voltage (110 V or 230 V) is displayed.

Test terminals:

Isub	Socket LN – Socket PE, P/S
Isub-S	Socket LN – P/S

11.5 Differential Leakage current

Differential leakage current

	Range	Resolution	Accuracy
Idiff	0.01 mA ... 19.99 mA	0.01 mA	±(3 % of reading + 5 D)

Power (active)

	Range	Resolution	Accuracy
P	0.00 W... 19.99 W	0.01 W	±(5 % of reading + 5 D)
	20.0 W... 199.9 W	0.1 W	± 5 % of reading
	200 W ... 1999 W	1 W	± 5 % of reading
	2.00 kW ... 3.70 kW	10 W	± 5 % of reading

Operating range (acc. to EN 61557-16)0.01 mA ... 19.99 mA

Influence of load current < 0.02 mA/A

Test terminals:

Idiff	Socket L,N – Socket PE, P/S
P	Socket L – Socket N

11.6 PE leakage current

PE leakage current

	Range	Resolution	Accuracy
Ipe	0.010 mA ... 1.999 mA	0.001 mA	±(3 % of reading + 3 D)
Ipe, a.c. Ipe, d.c.	2.00 mA ... 19.99 mA	0.01 mA	±(5 % of reading)

Power (active)

	Range	Resolution	Accuracy
P	0.00 W... 19.99 W	0.01 W	±(5 % of reading + 5 D)
	20.0 W... 199.9 W	0.1 W	± 5 % of reading
	200 W ... 1999 W	1 W	± 5 % of reading
	2.00 kW ... 3.70 kW	10 W	± 5 % of reading

Operating range (acc. to EN 61557-16)0.010 mA ... 19.99 mA

Test terminals:

Ipe	Socket L,N – Socket PE
P	Socket L – Socket N

11.7 Touch leakage current

Touch leakage current

	Range	Resolution	Accuracy
--	-------	------------	----------

Itou	0.010 mA ... 1.999 mA	0.001 mA	±(3 % of reading + 3 D)
Itou, a.c. Itou, d.c.	2.00 mA ... 19.99 mA	0.01 mA	±(5 % of reading)

Power (active)

	Range	Resolution	Accuracy
P	0.00 W...19.99 W	0.01 W	±(5 % of reading + 5 D)
	20.0 W...199.9 W	0.1 W	± 5 % of reading
	200 W ... 1999 W	1 W	± 5 % of reading
	2.00 kW ... 3.70 kW	10 W	± 5 % of reading

Operating range (acc. to EN 61557-16)0.010 mA ... 19.99 mA

Test terminals:

Itou	Socket L,N – P/S
P	Socket L – Socket N

11.8 Power**Power (active)**

	Range	Resolution	Accuracy
P	0.00 W...19.99 W	0.01 W	±(5 % of reading + 5 D)
	20.0 W...199.9 W	0.1 W	± 5 % of reading
	200 W ... 1999 W	1 W	± 5 % of reading
	2.00 kW ... 3.70 kW	10 W	± 5 % of reading

Power (apparent)

	Range	Resolution	Accuracy
S	0.00 VA...19.99 VA	0.01 VA	±(5 % of reading + 10 D)
	20.0 VA...199.9 VA	0.1 VA	± 5 % of reading
	200 VA ... 1999 VA	1 VA	± 5 % of reading
	2.00 kVA...3.70 kVA	10 VA	± 5 % of reading

Power (reactive)

	Range	Resolution	Accuracy
Q	0.00 var ... 19.99 var	0.01 var	±(5 % of reading + 10 D)
	20.0 var ... 199.9 var	0.1 var	± 5 % of reading
	200 var ... 1999 var	1 var	± 5 % of reading
	2.00 kvar...3.70 kvar	10 var	± 5 % of reading

Power factor

	Range	Resolution	Accuracy
PF	0.00i ... 1.00i 0.00c ... 1.00c	0.01	±(5 % of reading + 5 D)

Total Harmonic Distortion (voltage)

	Range	Resolution	Accuracy
THDU	0.0 % ... 99.9 %	0.1 %	±(5 % of reading + 5 D)

Total Harmonic Distortion (current)

	Range	Resolution	Accuracy
THDI	0 mA ... 999 mA	1 mA	$\pm(5\% \text{ of reading} + 5 \text{ D})$
	1.00 A ... 16.00 A	0.01 A	$\pm 5\% \text{ of reading}$

Cos Φ

	Range	Resolution	Accuracy
Cos Phi	0.00i ... 1.00i 0.00c ... 1.00c	0.01	$\pm(5\% \text{ of reading} + 5 \text{ D})$

Voltage

	Range	Resolution	Accuracy
U	0.0 V ... 199.9 V	0.1 V	$\pm(3\% \text{ of reading} + 10 \text{ D})$
	200 V ... 264 V	1 V	$\pm 3\% \text{ of reading}$

Current

	Range	Resolution	Accuracy
I	0 mA ... 999 mA	1 mA	$\pm(3\% \text{ of reading} + 5 \text{ D})$
	1.00 A ... 16.00 A	0.01 A	$\pm 3\% \text{ of reading}$

Accuracy is valid within $0.5c \leq PF \leq 0.8i$

Test terminals:

P,S,Q,PF,THDU,THDI, Cos Phi, U,I	Socket L – Socket N
----------------------------------	---------------------

11.9 Leak's & Power**Power (active)**

	Range	Resolution	Accuracy
P	0.00 W...19.99 W	0.01 W	$\pm(5\% \text{ of reading} + 5 \text{ D})$
	20.0 W...199.9 W	0.1 W	$\pm 5\% \text{ of reading}$
	200 W ... 1999 W	1 W	$\pm 5\% \text{ of reading}$
	2.00 kW ... 3.70 kW	10 W	$\pm 5\% \text{ of reading}$

Power (apparent)

	Range	Resolution	Accuracy
S	0.00 VA...19.99 VA	0.01 VA	$\pm(5\% \text{ of reading} + 10 \text{ D})$
	20.0 VA...199.9 VA	0.1 VA	$\pm 5\% \text{ of reading}$
	200 VA ... 1999 VA	1 VA	$\pm 5\% \text{ of reading}$
	2.00 kVA...3.70 kVA	10 VA	$\pm 5\% \text{ of reading}$

Power (reactive)

	Range	Resolution	Accuracy
Q	0.00 var ... 19.99 var	0.01 var	$\pm(5\% \text{ of reading} + 10 \text{ D})$
	20.0 var ... 199.9 var	0.1 var	$\pm 5\% \text{ of reading}$
	200 var ... 1999 var	1 var	$\pm 5\% \text{ of reading}$
	2.00 kvar...3.70 kvar	10 var	$\pm 5\% \text{ of reading}$

Power factor

	Range	Resolution	Accuracy
PF	0.00i ... 1.00i	0.01	±(5 % of reading + 5 D)
	0.00c ... 1.00c		

Total Harmonic Distortion (voltage)

	Range	Resolution	Accuracy
THDU	0.0 % ... 99.9 %	0.1 %	±(5 % of reading + 5 D)

Total Harmonic Distortion (current)

	Range	Resolution	Accuracy
THDI	0 mA ... 999 mA	1 mA	±(5 % of reading + 5 D)
	1.00 A ... 16.00 A	0.01 A	±(5 % of reading)

Cos Φ

	Range	Resolution	Accuracy
Cos Phi	0.00i ... 1.00i	0.01	±(5 % of reading + 5 D)
	0.00c ... 1.00c		

Voltage

	Range	Resolution	Accuracy
U	0.0 V ... 199.9 V	0.1 V	±(3 % of reading + 10 D)
	200 V ... 264 V	1 V	± 3 % of reading

Current

	Range	Resolution	Accuracy
I	0 mA ... 999 mA	1 mA	±(3 % of reading + 5 D)
	1.00 A ... 16.00 A	0.01 A	± 3 % of reading

Differential leakage current

	Range	Resolution	Accuracy
Idiff	0.01 mA ... 19.99 mA	0.01 mA	±(3 % of reading + 5 D)

Operating range (acc. to EN 61557-16)0.01 mA ... 19.99 mA

Influence of load current< 0.02 mA/A

Touch leakage current

	Range	Resolution	Accuracy
Itou	0.010 mA ... 1.999 mA	0.001 mA	±(3 % of reading + 3 D)
	2.00 mA ... 19.99 mA	0.01 mA	± 5 % of reading

Operating range (acc. to EN 61557-16)0.010 mA ... 19.99 mA

Test terminals:

P,S,Q,PF,THDU,THDI, Cos Phi, U,I	Socket L – Socket N
Idiff	Socket L,N – Socket PE, P/S
Itou	Socket L,N – P/S

11.10 PRCD

Refer to chapter *Technical specifications* in 3-phase adapter instrument user manual.

11.11 PE conductor (PRCD)

PE conductor (Type = 2 pole, 3 pole, S(3 pole), S+)

	Range	Resolution	Accuracy
R	0.00 Ω ... 19.99 Ω	0.01 Ω	±(2 % of reading + 2 D)
	20.0 Ω ... 99.9 Ω	0.1 Ω	± 3 % of reading
	100.0 Ω ... 199.9 Ω	0.1 Ω	± 5 % of reading
	200 Ω ... 999 Ω	1 Ω	indicative

Operating range (acc. to EN 61557-4) 0.08 Ω ... 199.9 Ω
 Current source (at nominal mains voltage, use of standard accessories)
 > 0.2 A at R < 2 Ω
 Open circuit voltage < 9 V a.c.
 Extension cord compensation up to 5 Ω

Test terminals:

R	Socket PE – IEC PE
---	--------------------

11.12 RCD testing

General data:

Nominal residual current (A,AC) 10 mA, 15 mA, 30 mA, 100 mA, 300 mA, 500 mA, 1000 mA

Nominal residual current accuracy -0 / +0.1·IΔ; IΔ = IΔN, 2×IΔN, 5×IΔN
 -0.1·IΔ / +0; IΔ = 0.5×IΔN
 AS/NZS 3017 selected: ± 5 %

Sensitivity parameter supported PRCD, PRCD-3p, PRCD-2p, PRCD-S+, PRCD-K

Nominal residual current accuracy by using parameter Sensitivity:

Sensitivity: standard -0 / +0.1·IΔ; IΔ = IΔN, 2×IΔN, 5×IΔN
 -0.1·IΔ / +0; IΔ = 0.5×IΔN

Sensitivity: Ipe monitoring -0 / +0.1·IΔ; IΔ = 0.5×IΔN, 2×0.5×IΔN, 5×0.5×IΔN
 -0.1·IΔ / +0; IΔ = 0.5×0.5×IΔN

AS/NZS 3017 selected: ± 5 %

Test current shape Sine-wave (AC), pulsed (A, F), smooth DC (B, B+)

DC offset for pulsed test current < 2 mA (typical)

RCD type (non-delayed), S (time-delayed), PRCD, PRCD-2p, PRCD-3p, PRCD-S, PRCD-S+, PRCD-K, EV RCD, EV RCM, MI RCD

Test current starting polarity 0° or 180°

Voltage range 93 V ... 134 V (16 Hz ... 400 Hz)
 185 V ... 266 V (16 Hz ... 400 Hz)

RCD test current in relation to RCD type, nominal RCD current and multiplication factor

I _{ΔN} (mA)	I _{ΔN} × 1/2 (mA)			I _{ΔN} × 1 (mA)			I _{ΔN} × 2 (mA)			I _{ΔN} × 5 (mA)			RCD I _Δ		
	AC	A, F	B, B+	AC	A, F	B, B+	AC	A, F	B, B+	AC	A, F	B, B+	AC	A, F	B, B+
10	5	3.5	5	10	20	20	20	40	40	50	100	100	✓	✓	✓
30	15	10.5	15	30	42	60	60	84	120	150	212	300	✓	✓	✓
100	50	35	50	100	141	200	200	282	400	500	707	1000	✓	✓	✓
300	150	105	150	300	424	600	600	848	×	1500	×	×	✓	✓	✓
500	250	175	250	500	707	1000	1000	1410	×	2500	×	×	✓	✓	✓
1000	500	350	500	1000	1410	×	2000	×	×	×	×	×	✓	✓	×

- ×not applicable
- ✓applicable
- AC type.....sine wave test current
- A, F types.....pulsed current
- B, B+ types.....smooth DC current

RCD test current in relation to MI / EV RCD type and multiplication factor

I _{ΔN} (mA)	I _{ΔN} × 1/2 (mA)	I _{ΔN} × 1 (mA)	I _{ΔN} × 2 (mA)	I _{ΔN} × 5 (mA)	I _{ΔN} × 10 (mA)	I _{ΔN} × 33.33 (mA)	I _{ΔN} × 50 (mA)	RCD I _Δ	
	MI / EV a.c., d.c.	MI / EV a.c., d.c.	MI / EV a.c.	MI / EV a.c.	MI / EV d.c.	MI / EV d.c. (IEC 62955)	MI / EV d.c. (IEC 62752)	MI / EV a.c.	MI / EV d.c.
30 a.c.	15	30	60	150	×	×	×	✓	×
6 d.c.	3	6	×	×	60	200	300	×	✓

- ×not applicable
- ✓applicable
- MI / EV type (a.c. part).....sine wave test current
- MI / EV type (d.c. part).....smooth DC current

Test terminals:

All RCD testing results and sub-results	TP1
---	-----

11.12.1 RCD U_c – Contact voltage

Measuring range according to EN 61557 is 20.0 V ... 31.0 V for limit contact voltage 25 V
 Measuring range according to EN 61557 is 20.0 V ... 62.0 V for limit contact voltage 50 V

Contact voltage

	Range	Resolution	Accuracy
U _c	0.0 V... 19.9 V	0.1 V	(-0 % / +15 %) of reading ± 10 digits
	20.0 V ... 99.9 V	0.1 V	(-0 % / +15 %) of reading

The accuracy is valid if mains voltage is stable during the measurement and PE terminal is free of interfering voltages. Specified accuracy is valid for complete operating range.

- Test current max. 0.5×I_{ΔN}
- Limit contact voltage Custom, 12 V, 25 V, 50 V

11.12.2 RCD t – Trip-out time

Complete measurement range corresponds to EN 61557 requirements.
Maximum measuring times set according to selected reference for RCD testing.

Trip-out time

	Range	Resolution	Accuracy
t _{ΔN}	0.0 ms ... 40.0 ms	0.1 ms	±1 ms
	0.0 ms ... max. time*	0.1 ms	±3 ms

* For max. time see normative references in chapter **4.7.3.1 RCD standard**. This specification applies to max. time >40 ms.

Test current $\frac{1}{2} \times I_{\Delta N}$, $I_{\Delta N}$, $2 \times I_{\Delta N}$, $5 \times I_{\Delta N}$

$5 \times I_{\Delta N}$ is not available for $I_{\Delta N} = 1000$ mA (RCD type AC) or $I_{\Delta N} \geq 300$ mA (RCD types A, F).

$2 \times I_{\Delta N}$ is not available for $I_{\Delta N} = 1000$ mA (RCD types A, F).

Specified accuracy is valid for complete operating range.

11.12.3 RCD I – Trip-out current

Complete measurement range corresponds to EN 61557 requirements.

Trip-out current

	Range	Resolution I _Δ	Accuracy
I _Δ	0.2×I _{ΔN} ... 1.1×I _{ΔN} (AC type)	0.05×I _{ΔN}	±0.1×I _{ΔN}
	0.2×I _{ΔN} ... 1.0×I _{ΔN} (IEC 62752: EV RCD, EV RCM, MI RCD (a.c. part))	0.05×I _{ΔN}	±0.1×I _{ΔN}
	0.2×I _{ΔN,d.c.} ... 1.0×I _{ΔN,d.c.} (IEC 62752: EV RCD, EV RCM, MI RCD (d.c. part))	0.05×I _{ΔN,d.c.}	±0.1×I _{ΔN,d.c.}
	0.2×I _{ΔN} ... 1.0×I _{ΔN} (IEC 62955: EV RCD, EV RCM, MI RCD (a.c. part))	0.05×I _{ΔN}	±0.1×I _{ΔN}
	0.2×I _{ΔN,d.c.} ... 1.0×I _{ΔN,d.c.} (IEC 62955: EV RCD, EV RCM, MI RCD (d.c. part))	0.05×I _{ΔN,d.c.}	±0.1×I _{ΔN,d.c.}
	0.2×I _{ΔN} ... 1.5×I _{ΔN} (A type, I _{ΔN} ≥30 mA)	0.05×I _{ΔN}	±0.1×I _{ΔN}
	0.2×I _{ΔN} ... 2.2×I _{ΔN} (A type, I _{ΔN} <30 mA)	0.05×I _{ΔN}	±0.1×I _{ΔN}
	0.2×I _{ΔN} ... 2.2×I _{ΔN} (B type)	0.05×I _{ΔN}	±0.1×I _{ΔN}

Trip out-time

	Range	Resolution	Accuracy
t I _Δ	0 ms ... 300 ms	1 ms	±3 ms

U_c I_Δ – Contact voltage

	Range	Resolution	Accuracy
U _c I _Δ	0.0 V ... 19.9 V	0.1 V	(-0 % / +15 %) of reading ± 10 digits
	20.0 V ... 99.9 V	0.1 V	(-0 % / +15 %) of reading

The accuracy is valid if mains voltage is stable during the measurement and PE terminal is free of interfering voltages. Specified accuracy is valid for complete operating range.

Trip-out measurement is not available for $I_{\Delta N}=1000$ mA (RCD types A, F, B, B+).

11.12.4 RCD Auto

Refer to following chapters for technical specification of individual RCD tests:

11.12.1 RCD U_c – Contact voltage

11.12.2 RCD t – Trip-out time

11.12.3 RCD I – Trip-out current

11.13 Polarity

Test voltage (normal).....< 50 V

Test voltage (active).....mains voltage

Power consumption of tested device during the active test.....< 25 VA

Test terminals:

normal, active	Socket – IEC
----------------	--------------

11.14 Clamp current

True RMS current using 1000:1 current clamp

	Range	Resolution	Accuracy
I Idiff Ipe	0.00 mA ... 9.99 mA	0.01 mA	±(5 % of reading + 10 digits)
	10.0 mA ... 99.9 mA	0.1 mA	±(5 % of reading + 5 digits)
	100 mA ... 999 mA	1 mA	±(5 % of reading + 5 digits)
	1.00 A ... 9.99 A	0.01 A	±(5 % of reading + 5 digits)
	10.0 A ... 24.9 A	0.1 A	±(5 % of reading + 5 digits)

Accuracy of current transformer is not considered.

Frequency range of current clamp is not considered.

Test terminals:

I, Idiff, Ipe	Clamp terminals
---------------	-----------------

11.15 Insulation resistance Riso (welding equipment)

Riso

	Range	Resolution	Accuracy
Riso	0.08 M Ω ... 19.99 M Ω	0.01 M Ω	$\pm(3\%$ of reading + 2 D)
	20.0 M Ω ... 99.9 M Ω	0.1 M Ω	$\pm 5\%$ of reading
	100.0 M Ω ... 199.9 M Ω	0.1 M Ω	$\pm 10\%$ of reading

Output voltage

	Range	Resolution	Accuracy
Um	0 V ... 600 V	1 V	$\pm(3\%$ of reading + 2 D)

Operating range (acc. to EN 61557-2) 0.08 M Ω ... 199.9 M Ω

Nominal voltages Un..... 500 V (- 0 %, + 10 %)

Short circuit current max. 2.0 mA

Test terminals:

Riso LN-W	A 1422: Socket L1 L2 L3 N (16A-5p, 32A-5p or 16A-3p) – W1 W2
Riso W-PE	A 1422: Socket PE (16A-5p, 32A-5p or 16A-3p) – W1 W2
Riso LN-PE	A 1422: Socket L1 L2 L3 N (16A-5p, 32A-5p or 16A-3p) – Socket PE (16A-5p, 32A-5p or 16A-3p)
Riso LN(Class II) - P/S	A 1422: Socket L1 L2 L3 N (16A-5p, 32A-5p or 16A-3p) – MI 3325: P/S

11.16 Welding Circuit leakage (Ileak W-PE)

Refer to chapter *Technical specifications* in 3-phase adapter instrument user manual.

11.17 Primary Leakage (I diff)

Refer to chapter *Technical specifications* in 3-phase adapter instrument user manual.

11.18 No-load voltage

Refer to chapter *Technical specifications* in 3-phase adapter instrument user manual.

11.19 Voltage, frequency, and phase rotation

Test terminals:

All results	TP1
-------------	-----

11.19.1 Phase rotation

Nominal 3-phase system voltage range. 100 V_{AC} ... 550 V_{AC}

Nominal frequency range..... 14 Hz ... 500 Hz

Result displayed 1.2.3 or 3.2.1

11.19.2 Voltage

Voltage

	Range	Resolution	Accuracy
UIn, Ulpe, Unpe, U1pe, U2pe, U12, U13, U23	0.0 V ... 99.9 V	0.1 V	±(2 % of reading + 2 digits)
	100 V ... 550 V	1 V	

Result type True r.m.s. (TRMS)
 Nominal frequency range..... 0 Hz, 14 Hz ... 500 Hz
 Crosstalk < 0.3 % of max. applied voltage

11.19.3 Frequency

Frequency

	Range	Resolution	Accuracy
Freq.	0.00 Hz ... 9.99 Hz	0.01 Hz	±(0.2 % of reading + 1 digit)
	10.0 Hz ... 499.9 Hz	0.1 Hz	

Nominal voltage range..... 20 V ... 550 V

11.19.4 Online terminal voltage monitor

Terminal voltage monitor

	Range	Resolution	Accuracy
Terminal voltage	10 V ... 550 V	1 V	±(2 % of reading + 2 digits)

11.20 Insulation resistance ISO (Installations)

Insulation resistance (Uiso: 50 V, 100 V and 250 V)

	Range	Resolution	Accuracy
Riso	0.15 MΩ ... 19.99 MΩ	0.01 MΩ	±(5 % of reading + 3 digits)
	20.0 MΩ... 99.9 MΩ	0.1 MΩ	± 10 % of reading
	100.0 MΩ ... 199.9 MΩ		± 20 % of reading

Measuring range according to EN 61557 is 0.15 MΩ ... 199.9 MΩ.

Insulation resistance (Uiso: 500 V)

	Range	Resolution	Accuracy
Riso	0.15 MΩ ... 19.99 MΩ	0.01 MΩ	±(5 % of reading + 3 digits)
	20.0 MΩ ... 199.9 MΩ	0.1 MΩ	± 5 % of reading
	200 MΩ ... 999 MΩ	1 MΩ	± 10 % of reading

Measuring range according to EN 61557 is 0.15 MΩ ... 999 MΩ.

Insulation resistance (Uiso: 1000 V)

	Range	Resolution	Accuracy
Riso	0.15 MΩ ... 19.99 MΩ	0.01 MΩ	±(5 % of reading + 3 digits)

	20.0 M Ω ... 199.9 M Ω	0.1 M Ω	± 5 % of reading
	200 M Ω ... 999 M Ω	1 M Ω	± 20 % of reading

Measuring range according to EN 61557 is 0.15 M Ω ... 999.9 M Ω .

Test Voltage

	Range (V)	Resolution (V)	Accuracy
Um	0 V... 1200 V	1 V	$\pm(3$ % of reading + 3 digits)

Nominal voltages Uiso50 V_{DC}, 100 V_{DC}, 250 V_{DC}, 500 V_{DC}, 1000 V_{DC}

Open circuit voltage-0 %, +20 % of nominal voltage

Measuring current.....min. 1 mA at $R_N = U_N \times 1 \text{ k}\Omega/\text{V}$

Short circuit current max. 3 mA

Load pretest voltage < 20 V_{AC}, 125 Hz

Load pretest warning < 50 k Ω

Auto discharge after test.

Specified accuracy is valid if 3-wire test lead is used.

Specified accuracy is valid up to 100 M Ω if relative humidity is > 85 %.

In case the instrument gets moistened, the results could be impaired. In such case, it is recommended to dry the instrument and accessories for at least 24 hours.

The error in operating conditions could be at most the error for reference conditions (specified in the manual for each function) ± 5 % of measured value.

Test terminals:

Riso, Um	TP1
----------	-----

11.21 Varistor test

DC voltage

	Range	Resolution	Accuracy
Udc	0 V ... 1000 V	1 V	$\pm(3$ % of reading + 3 digits)

AC voltage

	Range	Resolution	Accuracy
Uac	0 V ... 625 V	1 V	Consider accuracy of DC voltage

Measurement principle d.c. voltage ramp

Test voltage slope 100 V/s

Threshold current 1 mA

Test terminals:

Uac, Udc	TP1
----------	-----

11.22 R low - Resistance of earth connection and equipotential bonding

Resistance

	Range	Resolution	Accuracy
R	0.16 Ω ... 19.99 Ω	0.01 Ω	$\pm(3$ % of reading + 3 digits)

	20.0 Ω ... 199.9 Ω	0.1 Ω	± 5 % of reading
	200 Ω ... 1999 Ω	1 Ω	

Measuring range according to EN 61557 is 0.16 Ω ... 1999 Ω .

Resistance R+, R-

	Range	Resolution	Accuracy
R+, R-	0.0 Ω ... 199.9 Ω	0.1 Ω	±(5 % of reading + 5 digits)
	200 Ω ... 1999 Ω	1 Ω	

Open-circuit voltage.....6.5 V_{DC} ... 18 V_{DC}

Measuring current.....min. 200 mA into load resistance of 2 Ω

Test lead compensation.....up to 5 Ω

Automatic polarity reversal of the test voltage.

Test terminals:

R	TP1
---	-----

11.23 Z loop – Fault loop impedance and prospective fault current

Fault loop impedance

	Range	Resolution	Accuracy
Z	0.12 Ω ... 9.99 Ω	0.01 Ω	±(3 % of reading + 3 digits)
	10.0 Ω ... 99.9 Ω	0.1 Ω	
	100 Ω ... 999 Ω	1 Ω	± 10 % of reading
	1.00 k Ω ... 9.99 k Ω	10 Ω	

Measuring range according to EN 61557 is 0.12 Ω ... 9.99 k Ω .

Prospective fault current

	Range (A)	Resolution	Accuracy
I _{psc}	0.00 A ... 9.99 A	0.01 A	Consider accuracy of fault loop resistance measurement
	10.0 A ... 99.9 A	0.1 A	
	100 A ... 999 A	1 A	
	1.00 kA ... 9.99 kA	10 A	
	10.0 kA ... 23.0 kA	100 A	

Voltage U_{lpe}

	Range	Resolution	Accuracy
U _{lpe}	0 V ... 550 V	1 V	±(2 % of reading + 2 digits)

The accuracy is valid if mains voltage is stable during the measurement.

Test current (at 230 V).....20 A (10 ms)

Nominal voltage range.....93 V ... 134 V (16 Hz ... 400 Hz)
185 V ... 266 V (16 Hz ... 400 Hz)

R, X_L values are indicative.

Test terminals:

Z	TP1
---	-----

11.24 Zs rcd – Fault loop impedance and prospective fault current in system with RCD

Fault loop impedance

	Range	Resolution	Accuracy I _{test} =normal	Accuracy I _{test} =low
Z	0.00 Ω... 9.99 Ω	0.01 Ω	±(5 % of reading + 10 digits)	±(5 % of reading + 12 digits)
	10.0 Ω... 99.9 Ω	0.1 Ω		
	100 Ω ... 999 Ω	1 Ω	± 10 % of reading	± 10 % of reading
	1.00 kΩ ... 9.99 kΩ	10 Ω		

Measuring range according to EN 61557 is 0.46 Ω ... 9.99 kΩ for I_{test} = normal and 0.48 Ω ... 9.99 kΩ for I_{test} = low.

Accuracy may be impaired in case of heavy noise on mains voltage.

Prospective fault current

	Range	Resolution	Accuracy
I _p sc	0.00 A ... 9.99 A	0.01 A	Consider accuracy of fault loop resistance measurement
	10.0 A ... 99.9 A	0.1 A	
	100 A ... 999 A	1 A	
	1.00 kA ... 9.99 kA	10 A	
	10.0 kA ... 23.0 kA	100 A	

Voltage U_{lpe}

	Range	Resolution	Accuracy
U _{lpe}	0 V... 550 V	1 V	±(2 % of reading + 2 digits)

Nominal voltage range.....93 V ... 134 V (16 Hz ... 400 Hz)
185 V ... 266 V (16 Hz ... 400 Hz)

No trip out of RCD. R, X_L values are indicative.

Test terminals:

Z	TP1
---	-----

11.25 Z line – Line impedance and prospective short-circuit current

Line impedance

	Range	Resolution	Accuracy
Z	0.12 Ω ... 9.99 Ω	0.01 Ω	±(3 % of reading + 3 digits)
	10.0 Ω ... 99.9 Ω	0.1 Ω	
	100 Ω ... 999 Ω	1 Ω	± 10 % of reading
	1.00 kΩ ... 9.99 kΩ	10 Ω	

Measuring range according to EN 61557 is 0.12 Ω ... 9.99 kΩ.

Prospective short-circuit current

	Range	Resolution	Accuracy
I _p sc	0.00 A ... 0.99 A	0.01 A	Consider accuracy of line resistance measurement
	1.0 A ... 99.9 A	0.1 A	

11.31 ELR Current injection

This test is performed in combination with an external test adapter / instrument.
For technical specification refer to *MI 3144 Euro Z 800 V Instruction manual*.

11.32 ELR Combination time test

This test is performed in combination with an external test adapter / instrument.
For technical specification refer to *MI 3144 Euro Z 800 V Instruction manual*.

11.33 U touch – Touch voltage

This test is performed in combination with an external test adapter / instrument.
For technical specification refer to *MI 3143 Euro Z 440 V and MI 3144 Euro Z 800 V Instruction manual*.

11.34 Current clamp meter

This test is performed in combination with an external test adapter / instrument.
For technical specification refer to *MI 3144 Euro Z 800 V Instruction manual*.

11.35 EVSE Diagnostic test

This test is performed in combination with an external test adapter / instrument.
For technical specification refer to *A 1632 eMobility Analyser Instruction manual*.

11.36 Power CLAMP

This test is performed in combination with an external test adapter / instrument.
For technical specification refer to *MD 9273 Leakage Clamp meter with Bluetooth® communication Instruction manual*.

11.37 Voltage CLAMP

This test is performed in combination with an external test adapter / instrument.
For technical specification refer to *MD 9273 Leakage Clamp meter with Bluetooth® Communication Instruction manual*.

11.38 Current CLAMP

This test is performed in combination with an external test adapter / instrument.
For technical specification refer to *MD 9273 Leakage Clamp meter with Bluetooth® Communication Instruction manual*.

11.39 Inrush CLAMP

This test is performed in combination with an external test adapter / instrument.

For technical specification refer to *MD 9273 Leakage Clamp meter with Bluetooth® Communication Instruction manual*.

11.40 Harmonics U CLAMP

This test is performed in combination with an external test adapter / instrument.

For technical specification refer to *MD 9273 Leakage Clamp meter with Bluetooth® Communication Instruction manual*.

11.41 Harmonics I CLAMP

This test is performed in combination with an external test adapter / instrument.

For technical specification refer to *MD 9273 Leakage Clamp meter with Bluetooth® Communication Instruction manual*.

11.42 Voltage Drop

Voltage drop

	Range	Resolution	Accuracy
ΔU	0.0 % ... 99.9 %	0.1 %	Consider accuracy of line impedance measurement(s)*

U_{In} , I_{psc} , Z_{ref} , Z

For technical specification refer to chapter **11.25 Z line – Line impedance and prospective short-circuit current**.

Z_{REF} measuring range0.00 Ω ... 19.99 Ω

Test current (at 230 V) 20 A (10 ms)

Nominal voltage range93 V ... 134 V (16 Hz ... 400 Hz)

185 V ... 266 V (16 Hz ... 400 Hz)

321 V ... 485 V (16 Hz ... 400 Hz)

*See chapter **6.2.23 Voltage Drop** for more information about calculation of voltage drop result.

Test terminals:

ΔU	TP1
------------	-----

11.43 Discharging time

Discharging time

	Range	Resolution	Accuracy
t	0.0 s ... 9.9 s	0.1 s	$\pm(5\% \text{ of reading} + 2 \text{ digits})$

Measuring range (acc. to EN 61557-14)0.8 s ... 9.9 s

Residual voltage

	Range	Resolution	Accuracy
U_{res}	0.0 V ... 99.9 V	0.1 V	$\pm(5\% \text{ of reading} + 3 \text{ digits})$
	100 V ... 372 V	1 V	

Peak voltage

	Range	Resolution	Accuracy
Up	0 V ... 372 V	1 V	±(5 % of reading + 3 digits)

RMS voltage

	Range	Resolution	Accuracy
U	70.0 V ... 99.9 V	0.1 V	±(2 % of reading + 2 digits)
	100 V ... 263 V	1 V	

Frequency

	Range	Resolution	Accuracy
Freq	45.0 Hz ... 65.0 Hz	0.1 Hz	±(0.2 % of reading + 1 digit)

Nominal frequency range.....d.c., 45 Hz – 65 Hz

High limits.....1 s, 5 s

Threshold voltage.....34 V, 60 V, 120 V

Input resistance20 MΩ

Test terminals:

All results	TP1
-------------	-----

11.44 Rpe – PE conductor resistance

RCD: No

R – PE conductor resistance

	Range	Resolution	Accuracy
Rpe	0.00 Ω ... 19.99 Ω	0.01 Ω	±(5 % of reading + 5 digits)
	20.0 Ω ... 99.9 Ω	0.1 Ω	
	100.0 Ω ... 199.9 Ω	0.1 Ω	± 10 % of reading
	200 Ω ... 1999 Ω	1 Ω	

Measuring current.....min. 200 mA into PE resistance of 2 Ω

RCD: Yes, no trip out of RCD

R – PE conductor resistance

	Range	Resolution	Accuracy
Rpe	0.00 Ω ... 19.99 Ω	0.01 Ω	±(5 % of reading + 10 digits)
	20.0 Ω ... 99.9 Ω	0.1 Ω	
	100.0 Ω ... 199.9 Ω	0.1 Ω	± 10 % of reading
	200 Ω ... 1999 Ω	1 Ω	

Accuracy may be impaired in case of heavy noise on mains voltage.

Measuring current.....< 15 mA

Nominal voltage range.....93 V ... 134 V (16 Hz ... 400 Hz)

185 V ... 266 V (16 Hz ... 400 Hz)

Test terminals:

Rpe	TP1
-----	-----

11.45 General data

Power supply

Supply voltage, frequency	110 V / 230 V AC, 50 Hz / 60 Hz
Supply voltage tolerance	±10 %
Max. power consumption	300 VA (without load on mains test socket)
Max. load	10 A continuous, 16 A short duration, 1.5 kW motor
Mains supply overvoltage category	CAT II / 300V
Altitude	≤ 2000 m

Measuring categories

Mains test socket	CAT II / 300 V
IEC test socket	CAT II / 300 V
P/S terminal	CAT II / 300 V
C1,C2,P1,P2 terminals	CAT II / 300 V
Clamp inputs	CAT II / 300 V
Plug test cable	CAT II / 300 V
TP1 test socket	CAT III / 300 V

Protection classifications

Power supply	Class I
HV output	5 kV a.c. double insulation
Pollution degree	2
Degree of protection	IP 54 (closed case) IP 40 (open case) IP 20 (mains test socket)
Case	Shock proof plastic / portable
Dimensions (w×h×d):	42 cm × 18 cm × 33 cm
Weight	13.3 kg

Signal ports

Display	Colour TFT display, 4.3 inch, 480 x 272 pixels
Touch screen	Capacitive
Memory	depends on microSD card size
INPUTS	24 Vmax, earthed, DB9 connector
OUTPUTS	24 Vmax, earthed, 1.5 A max, DB9 connector, NO relays
RS232 interfaces	two DB9 ports (RS 232-1 (PC), RS 232-2)
USB 2.0	Standard USB Type B
Bluetooth	Class 2
Ethernet	Dynamic IP (DHCP)

Blackbox

USB, Bluetooth, Ethernet baud rate	115200
Blackbox serial port	RS 232-2 (Null modem adapter required)
Blackbox serial port baud rate	9600

EMC

Emission	Class B (portable equipment used in controlled EM environments: domestic, commercial, light industry)
Immunity	Industrial environment

Reference conditions

Reference temperature range: 15 °C ... 35 °C

Reference humidity range: 35 % ... 65 % RH

Operation conditions

Working temperature range: 0 °C ... +40 °C

Maximum relative humidity: 85 % RH (0 °C ... 40 °C), non-condensing

Storage conditions

Temperature range: -10 °C ... +60 °C

Maximum relative humidity: 90 % RH (-10 °C ... +40 °C)

..... 80 % RH (40 °C ... 60 °C)

Accuracies apply for 1 year in reference conditions. Temperature coefficient outside these limits is 0.2 % of measured value per °C plus 1 digit, otherwise noted.















Fuses

F1, F2, F 3.15 A / 250 V, 20 mm x 5 mm / 1500 A

F3, F4, T 16 A / 250 V, 32 mm x 6.3 mm / 1500 A

Appendix A Structure objects in MultiServicerXD

Structure elements used in Memory Organizer are instrument's Profile dependent.

Symbol	Default name	Description
	Node	Node
	Project	Project
	Location	Location
	Client	Client
	Element	Universal element
	Appliance	Appliance (basic description)
	Appliance FD	Appliance (full description)
	Welding device	Welding device (basic description)
	Welding device FD	Welding device (full description)
	Machine	Electrical machine
	Switchgear	Switchgear
	EVSE	Electro-Vehicle supply Equipment
	Level1	1st sublevel of machine / switchgear / EVSE
	Level 2	2nd sublevel of machine / switchgear / EVSE
	Level 3	3rd sublevel of machine / switchgear/ EVSE

Appendix B Profile Notes

Instrument supports working with multiple Profiles. This appendix contains collection of minor modifications related to particular country requirements. Some of the modifications mean modified listed function characteristics related to main chapters and others are additional functions. Some minor modifications are related also to different requirements of the same market that are covered by various suppliers.

B.1 Profile Austria (AUAF)

Testing special delayed G type RCD supported.

Modifications in chapters:

6.2.34 RCD U_c – Contact voltage,

6.2.35 RCD t – Trip-out time

6.2.36 RCD I – Trip-out current

6.2.37 RCD Auto – RCD Auto test

Special delayed G type RCD selection added in the **Selectivity** parameter in **Test Parameters / Limits** section as follows:

Selectivity Characteristic [--, S, G]

Time limits are the same as for general type RCD and contact voltage is calculated the same as for general type RCD.

Selective (time delayed) RCDs and RCDs with (G) - time delayed characteristic demonstrate delayed response characteristics. They contain residual current integrating mechanism for generation of delayed trip out. However, contact voltage pre-test in the measuring procedure also influences the RCD and it takes a period to recover into idle state. Time delay of 30 s is inserted before performing trip-out test to recover S type RCD after pre-tests and time delay of 5 s is inserted for the same purpose for G type RCD.

Table 6.8: Relations between U_c and $I_{\Delta N}$ changed as follows:

RCD type		Contact voltages U_c proportional to	Rated $I_{\Delta N}$
AC, EV, MI (a.c. part)	--	$1.05 \times I_{\Delta N}$	any
	G		
AC	S	$2 \times 1.05 \times I_{\Delta N}$	≥ 30 mA
A, F	--	$1.4 \times 1.05 \times I_{\Delta N}$	
A, F	G	$2 \times 1.4 \times 1.05 \times I_{\Delta N}$	< 30 mA
A, F	S		
A, F	--	$2 \times 1.05 \times I_{\Delta N}$	any
A, F	G		
A, F	S	$2 \times 2 \times 1.05 \times I_{\Delta N}$	
B, B+	--	$2 \times 1.05 \times I_{\Delta N}$	any
B, B+	S		
B, B+	S	$2 \times 2 \times 1.05 \times I_{\Delta N}$	

Technical specifications unchanged.

B.2 Profile Hungary (AUAE)

Fuse type gR added to the fuse tables. Refer to *Fuse tables guide* for detailed information on fuse data.

Modifications in chapter 6.2.37 RCD Auto – RCD Auto test

Added tests with multiplication factor 2.

Modification of RCD Auto test procedure

RCD Auto test inserted steps	Notes
<ul style="list-style-type: none"> Re-activate RCD. Test with $2 \times I_{\Delta N}$, (+) positive polarity (new step 5). 	RCD should trip-out
<ul style="list-style-type: none"> Re-activate RCD. Test with $2 \times I_{\Delta N}$, (-) negative polarity (new step 6). 	RCD should trip-out

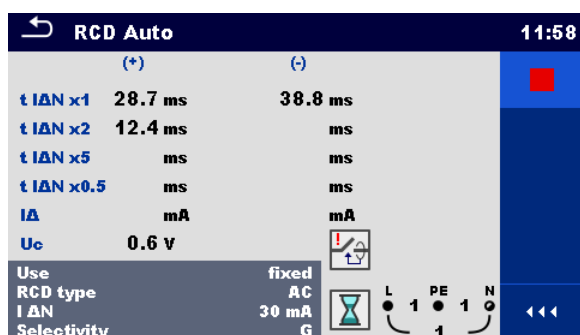

Inserted new Step 5

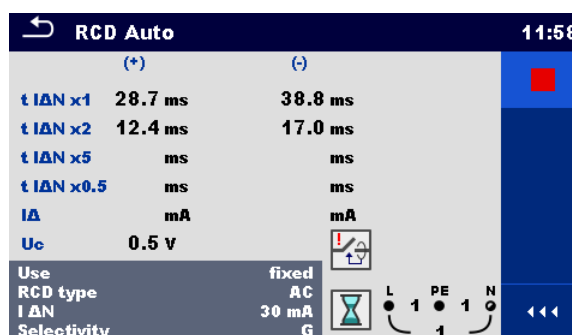

Inserted new Step 6

Figure B.1: Example of individual steps in RCD Auto test – Inserted 2 new steps

Test results / sub-results

$t I_{\Delta N}$ d.c. x1, (+) ¹⁾	Step 1 trip-out time ($I_{\Delta}=I_{\Delta N}$ d.c., (+) positive polarity)
$t I_{\Delta N}$ d.c. x1, (-) ¹⁾	Step 2 trip-out time ($I_{\Delta}=I_{\Delta N}$ d.c., (-) negative polarity)
$t I_{\Delta N}$ x1, (+)	Step 3 trip-out time ($I_{\Delta}=I_{\Delta N}$, (+) positive polarity) Non-operating time for a.c. current (IEC 62955).
$t I_{\Delta N}$ x1, (-)	Step 4 trip-out time ($I_{\Delta}=I_{\Delta N}$, (-) negative polarity) Non-operating time for a.c. current (IEC 62955).
$t I_{\Delta N}$ x2, (+)	Step 5 trip-out time ($I_{\Delta}=2 \times I_{\Delta N}$, (+) positive polarity)
$t I_{\Delta N}$ x2, (-)	Step 6 trip-out time ($I_{\Delta}=2 \times I_{\Delta N}$, (-) negative polarity)
$t I_{\Delta N}$ x5, (+)	Step 7 trip-out time ($I_{\Delta}=5 \times I_{\Delta N}$, (+) positive polarity)
$t I_{\Delta N}$ x5, (-)	Step 8 trip-out time ($I_{\Delta}=5 \times I_{\Delta N}$, (-) negative polarity)
$t I_{\Delta N}$ x0.5, (+)	Step 9 trip-out time ($I_{\Delta}=1/2 \times I_{\Delta N}$, (+) positive polarity)
$t I_{\Delta N}$ x0.5, (-)	Step 10 trip-out time ($I_{\Delta}=1/2 \times I_{\Delta N}$, (-) negative polarity)
I_{Δ} (+)	Step 11 trip-out current ((+) positive polarity)
I_{Δ} (-)	Step 12 trip-out current ((-) negative polarity)
I_{Δ} d.c. (+) ¹⁾	Step 13 trip-out current ((+) positive polarity)
I_{Δ} d.c. (-) ¹⁾	Step 14 trip-out current ((-) negative polarity)
U_c	Contact voltage for rated $I_{\Delta N}$

¹⁾ Result is displayed only when parameter Use is set to 'other' and parameter Type to 'EV RCD', 'EV RCM' or 'MI RCD'.

B.3 Profile Finland (AUAG)

Ia(Ipsc) limit modified in fuse types gG, NV, B, C, D and K.
Refer to **Fuse tables guide** for detailed information on fuse data.

B.4 Profile UK (AUAB)

Modifications in chapter 4.7.3 Settings:

Setting options:

Option	Description
Isc factor	Short circuit current Isc in the supply system is important for selection or verification of protective circuit breakers (fuses, over-current breaking devices, RCDs). The value should be set according to local regulative.

is replaced with

Option	Description
Z factor	Impedance correction scaling factor [1, 0.80], Default value: 0.80 The value should be set according to local regulative.

Default value of **RCD Standard** parameter is changed to BS 7671.

Modifications in chapters:

6.2.16 Z loop – Fault loop impedance and prospective fault current

6.2.17 Z loop mΩ – High precision fault loop impedance and prospective fault current

6.2.18 Zs rcd – Fault loop impedance and prospective fault current in system with RCD

6.2.19 Z line – Line impedance and prospective short-circuit current

6.2.20 Z line mΩ – High precision line impedance and prospective short-circuit current

6.2.22 Z auto - Auto test sequence for fast line and loop testing

6.2.23 Voltage Drop

Test parameters

Fuse Type	Selection of fuse type [Off, Custom, gG, NV, B, C, D, K, Z, L, U]
Isc factor	Correction factor Isc [Custom, 0.2 ... 3.0]

Test limits

Ia(Ipsc)	Minimum fault current for selected fuse
-----------------	---

are replaced with

Test parameters

Fuse Type	Selection of fuse type [Off, Custom, BS 88-2, BS 88-3, BS 3036, BS 1362, B, C, D]
Z factor	Z factor [Custom, 0.8, 1]

Test limits

Zlim(Z)
Zlim(Z (LPE), Z (LN)) Maximum loop / line impedance for selected fuse or custom value.

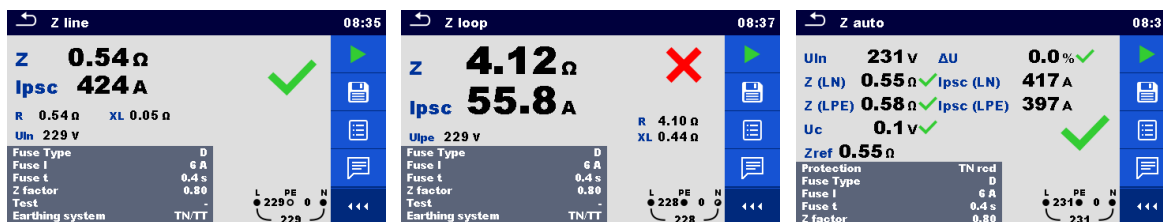

Figure B.2: Examples of Z line, Z loop and Z auto measurement result

Prospective fault / short circuit current I_{PSC} is calculated from measured impedance as follows:

$$I_{PSC} = \frac{U_N}{Z}$$

Loop / line impedance limit $Z_{Lim(Z)}$ for selected fuse is calculated from the following formula:

$$Z_{Lim(Z)} = Scaling_factor \times Z_{Lim}$$

where:

- Zlim Maximum loop / line impedance for selected fuse (according to BS 7671)
- Scaling factor..... Impedance correction factor (Z factor)
- Un..... Nominal U_{L-PE} voltage

Modifications in chapter 6.2.34 RCD Uc – Contact voltage:

Added new sub-result:

Test results / sub-results

Rmax Maximum earth fault loop resistance value according to BS 7671

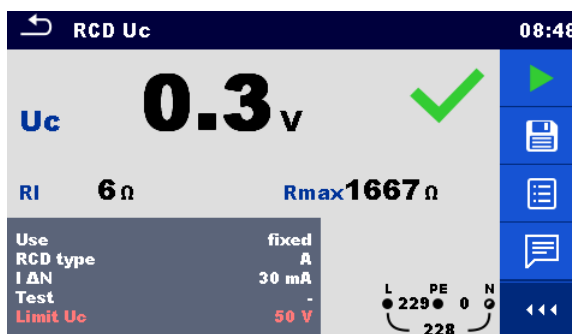

Figure B.3: Example of Contact voltage measurement result

Modifications in chapter 6.2.35 RCD t – Trip-out time:

Test parameters

X IΔN Multiplication factor for test current [0.5, 1, 2, 5]

is replaced with

X I Δ N Multiplication factor for test current [0.5, 1, 2, 5, 8.33 (250 mA)¹⁾]

- ¹⁾ Parameter value is available only for I Δ N = 30 mA, A type RCD and Selectivity G. Test has reference in BS EN 61008 / BS EN 61009.

B.5 Profile AUS (AUAD)

Modifications in chapter **4.7.3 Settings**:

Setting options:

Option	Description
Isc factor	Short circuit current I _{sc} in the supply system is important for selection or verification of protective circuit breakers (fuses, over-current breaking devices, RCDs). The value should be set according to local regulative.

is replaced with

Option	Description
Z factor	Impedance correction scaling factor [1, 1.04], Default value: 1 The value should be set according to local regulative.

Default value of **RCD Standard** parameter is changed to AS/NZS 3017.

Modifications in chapters:

6.2.16 Z loop – Fault loop impedance and prospective fault current

6.2.17 Z loop m Ω – High precision fault loop impedance and prospective fault current

6.2.18 Z_s rcd – Fault loop impedance and prospective fault current in system with RCD

6.2.19 Z line – Line impedance and prospective short-circuit current

6.2.20 Z line m Ω – High precision line impedance and prospective short-circuit current

6.2.22 Z auto - Auto test sequence for fast line and loop testing

6.2.23 Voltage Drop

Test parameters

Fuse Type	Selection of fuse type [Off, Custom, gG, NV, B, C, D, K, Z, L, U]
Isc factor	Correction factor I _{sc} [Custom, 0.2 ... 3.0]

Test limits

I_a(I_psc)	Minimum fault current for selected fuse
---------------------------------------	---

are replaced with

Test parameters

Fuse Type	Selection of fuse type [Off, Custom, B, C, D, Fuse]
Z factor	Z factor [Custom, 1, 1.04]

Test limits

Z_{lim}(Z) Z_{lim}(Z (LPE), Z (LN))	Maximum loop / line impedance for selected fuse or custom value.
--	--

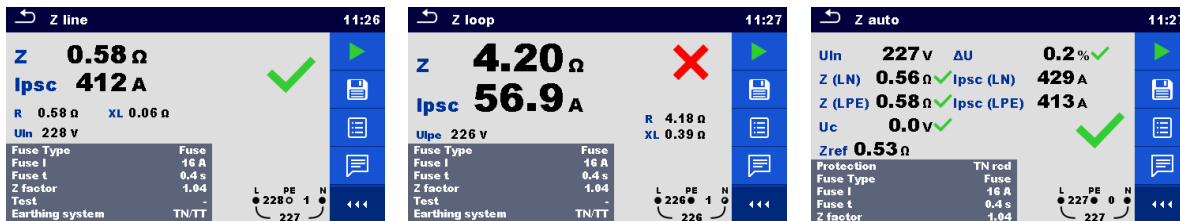

Figure B.4: Examples of Z line, Z loop and Z auto measurement result

Prospective fault / short circuit current I_{PSC} is calculated from measured impedance as follows:

$$I_{PSC} = \frac{U_N}{Z}$$

Loop / line impedance limit $Z_{Lim(Z)}$ for selected fuse is calculated from the following formula:

$$Z_{Lim(Z)} = Scaling_factor \times Z_{Lim}$$

where:

Zlim Maximum loop / line impedance for selected fuse

Scaling factor..... Impedance correction factor (Z factor)

Un..... Nominal $U_{L,PE}$ voltage

Modifications in chapter 6.2.35 RCD t – Trip-out time:

Added new test parameter and sub-result:

Test parameter

Random phase [No, Yes]

Test results / sub-results

Phase Starting phase (if Random phase parameter is enabled)

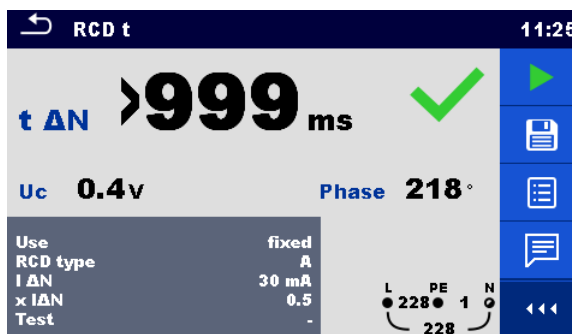

Figure B.5: Example of Trip-out time measurement result with enabled Random phase

Modifications in chapter 6.2.37 RCD Auto – RCD Auto test:

Added new test parameter:

Test parameter

Random phase [No, Yes]

Added tests with multiplication factor 2.

Modification of RCD Auto test procedure

RCD Auto test inserted steps	Notes
<ul style="list-style-type: none"> Re-activate RCD. Test with $2 \times I_{\Delta N}$, (+) positive polarity (new step 5). 	RCD should trip-out
<ul style="list-style-type: none"> Re-activate RCD. Test with $2 \times I_{\Delta N}$, (-) negative polarity (new step 6). 	RCD should trip-out

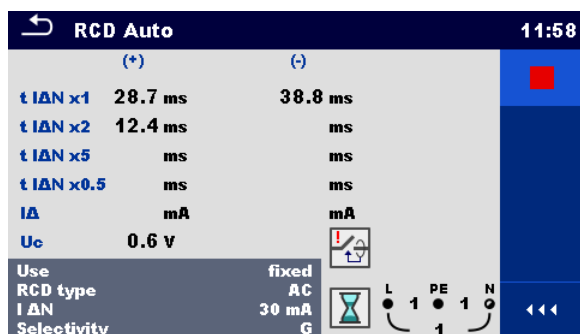

Inserted new Step 5

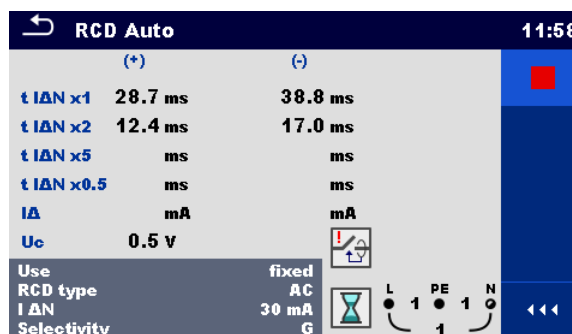

Inserted new Step 6

Figure B.6: Example of individual steps in RCD Auto test – Inserted 2 new steps

Test results / sub-results

t IΔN d.c. x1, (+) ¹⁾	Step 1 trip-out time ($I_{\Delta}=I_{\Delta N}$ d.c., (+) positive polarity)
t IΔN d.c. x1, (-) ¹⁾	Step 2 trip-out time ($I_{\Delta}=I_{\Delta N}$ d.c., (-) negative polarity)
t IΔN x1, (+)	Step 3 trip-out time ($I_{\Delta}=I_{\Delta N}$, (+) positive polarity) Non-operating time for a.c. current (IEC 62955).
t IΔN x1, (-)	Step 4 trip-out time ($I_{\Delta}=I_{\Delta N}$, (-) negative polarity) Non-operating time for a.c. current (IEC 62955).
t IΔN x2, (+)	Step 5 trip-out time ($I_{\Delta}=2 \times I_{\Delta N}$, (+) positive polarity)
t IΔN x2, (-)	Step 6 trip-out time ($I_{\Delta}=2 \times I_{\Delta N}$, (-) negative polarity)
t IΔN x5, (+)	Step 7 trip-out time ($I_{\Delta}=5 \times I_{\Delta N}$, (+) positive polarity)
t IΔN x5, (-)	Step 8 trip-out time ($I_{\Delta}=5 \times I_{\Delta N}$, (-) negative polarity)
t IΔN x0.5, (+)	Step 9 trip-out time ($I_{\Delta}=1/2 \times I_{\Delta N}$, (+) positive polarity)
t IΔN x0.5, (-)	Step 10 trip-out time ($I_{\Delta}=1/2 \times I_{\Delta N}$, (-) negative polarity)
IΔ (+)	Step 11 trip-out current ((+) positive polarity)
IΔ (-)	Step 12 trip-out current ((-) negative polarity)
IΔ d.c. (+) ¹⁾	Step 13 trip-out current ((+) positive polarity)
IΔ d,c. (-) ¹⁾	Step 14 trip-out current ((-) negative polarity)
Uc	Contact voltage for rated $I_{\Delta N}$

¹⁾ Result is displayed only when parameter Use is set to 'other' and parameter Type to 'EV RCD', 'EV RCM' or 'MI RCD'.

Appendix C Print labels and write / read RFID/NFC tags

The instrument supports different printers, label size forms and two tag formats (PAT and Generic); listed parameters setting is described in chapter **4.9 Devices**. By setting the printer, label size forms and tag formats are limited.

Tag content can be presented as text only or arranged as text area and machine-readable code area – barcode or QR code – in addition.

The instrument supports RFID / NFC reader / writer device; tag type supported is NTAG216.

Please check with Metrel or distributor which printers and labels are supported in your MultiServicerXD instrument.

C.1 PAT tag format

It is intended for tagging of individual appliance with Auto Sequence® test data. To start printing, Auto Sequence® should be finished and saved or reopened from memory structure. When required, printing of two labels of the same test can be set.

Available tag data presented in text area are:

- › Auto Sequence® short Test code
- › Appliance ID
- › Appliance name
- › Test date
- › Retest date
- › Auto Sequence® test status
- › User name (who currently performed test or who performed saved test, if printed from memory)

Available tag data presented in machine-readable area are:

- › Auto Sequence® short Test code
- › Appliance ID
- › Appliance name
- › Test date
- › Test period (from appliance description)
- › Appliance location (from appliance description)
- › Auto Sequence® test status
- › User name (who currently performed test or who performed saved test, if printed from memory)
- › Auto Sequence® measurements results

Actual tag content depends on label type selection, when printing. Content of 1st and 2nd label is also adopted, when 2-label printing is selected.

Following tables describe tag content arrangement and its data for supported form sizes and chosen label type.

Label type	Form size W x H (mm)	Tag content arrangement	Data1st label	Data 2nd label
Classic	50 x 25.5	Barcode	Test code, appliance ID	Appliance ID
		Text	Test code, appliance ID, test or retest date, status, user	Appliance ID, test or retest date, status, user
QR		QR	Test code, appliance ID, appliance name, test date, test period, location, user, status, measurement results.	Appliance ID, appliance name, test date, test period, location, user, status
		Text	Test code, appliance ID, appliance name, test or retest date, status, user	Appliance ID, appliance name, test or retest date, status, user
Simple		Text	Appliance ID, appliance name, status, test or retest date, user	

Label type	Form size W x H (mm)	Tag content arrangement	Data1st label	Data 2nd label
Classic L	43 x 99	Barcode	Test code, appliance ID	Appliance ID
		Text	Test code, appliance ID, test and retest date, status, user	Appliance ID, test and retest date, status, user
QR L		QR	Test code, appliance ID, appliance name, test date, test period, location, user, status, measurement results.	Appliance ID, appliance name, test date, test period, location, user, status
		Text	Test code, appliance ID, appliance name, test and retest date, status, user	Appliance ID, appliance name, test and retest date, status, user

Label type	Size W x H (mm)	Tag content arrangement	Data1st label	Data 2nd label
Classic L (inverted)	100 x 50	Barcode	Test code, appliance ID	Appliance ID
		Text	Test code, appliance ID, test and retest date, status, user	Appliance ID, test and retest date, status, user
QR L (inverted)		QR	Test code, appliance ID, appliance name, test date, test period, location, user, status, measurement results.	Appliance ID, appliance name, test date, test period, location, user, status
		Text	Test code, appliance ID, appliance name, test and retest date, status, user	Appliance ID, appliance name, test and retest date, status, user

Notes:

- Applicable only for PAT measurements. Limited functionality for non PAT data.

- › 2nd label is intended to mark supply cords.
- › Data not available will not be printed on the label.
- › Test or Retest date: is set in the General Settings => Devices => Writing devices menu.
- › If Auto Sequence® was modified, its short code is marked with asterisk (*).

Following table describes data content written on RFID / NFC tag.

RFID / NFC tag type	Data
NTAG216	Test code, appliance ID, appliance name, test date, test period, location, user, status, measurement results.

Note:

- › Applicable only for PAT measurements. Limited functionality for non PAT data.

C.2 Generic tag format

It is intended for tagging structure objects (element, appliance, equipment), which could be tested and their location under parent structure object is important. Label printing can be started from selected structure object (element, appliance, equipment), even if no Auto Sequence® is associated with it, or from finished Auto Sequence® saved under it.

Tag data presented in text area are:

- › Parent structure object ID (name) (← Object_name)
- › Auto Sequence® short test code (if printing from Auto Sequence®; if printing from object field is omitted)
- › Object ID (name)
- › Test date (|→ DD.MM.YYYY) or Retest date (→| DD.MM.YYYY), which one is selected in General Settings => Devices => Writing devices menu
- › Status (printing from object: overall status of all tests appended to the object or sub-structure objects; printing from Auto Sequence®: its status)
- › User name (Printing from Auto Sequence: user who performed test; printing from object: current signed-in user)

Tag data presented in machine-readable area are:

- › Parent structure object ID (name)
- › Auto Sequence® short test code (if printing from Auto Sequence®; if printing from object field is omitted)
- › Object ID (name)
- › Test date
- › Test period (from appliance description)
- › Auto Sequence® status (field is omitted, if not printing from Auto Sequence®)
- › Object status (overall status of all tests appended to the object or sub-structure objects)
- › User name (Printing from Auto Sequence®: user who performed test; printing from object: current signed-in user)

Following table describes tag content arrangement and its data for supported label form size.

Form size W x H (mm)	Tag content arrangement	Data
50 x 25.5	Text	Parent object name, Test code, Object ID, test or retest date, status, user
	QR	Parent object name, Test code, Object ID, test date, test period, Auto Sequence® status, Object status, user.

Notes:

- › Data not available will not be printed on the label.
- › Object without appended Auto Sequence® test has no status!
- › If Auto Sequence® was modified, its short code is marked with asterisk (*).
- › Object status depends on all measurements (Auto Sequences® or Single tests) appended to the object or sub-structure objects, see chapter **5.1.2.1 Measurement status indication under the Structure object** for details.

Following table describes data content written on RFID / NFC tag.

RFID / NFC tag type	Data
NTAG216	Parent object name, Test code, Object ID, test date, test period, Auto Sequence® status, Object status, user.

Appendix D Default list of Auto Sequences®

Default list of Auto Sequences® for MI 3325 MultiServicerXD instrument is available on Metrel home page: <http://www.metrel.si>

.

Appendix E Programming of Auto Sequences® on Metrel ES Manager

The Auto Sequence® editor is a part of the Metrel ES Manager software. In Auto Sequence® editor Auto Sequences® can be pre-programmed and organized in groups, before uploaded to the instrument.

E.1 Auto Sequence® editor workspace

To enter Auto Sequence® editor’s workspace, select **Auto Sequence® Editor** in Home Tab of Metrel ES Manager PC SW. Auto Sequence® editor workspace is divided in four main areas. On the left side **1**, structure of selected group of Auto Sequence® is displayed. In the middle part of the workspace **2**, the elements of the selected Auto Sequence® are shown. On the right side, list of available single tests **3** and list of flow commands **4** are shown. Single test area contains three tabs, Measurements, Inspections and Custom Inspections tab. Custom Inspections and their tasks are programmed by user.

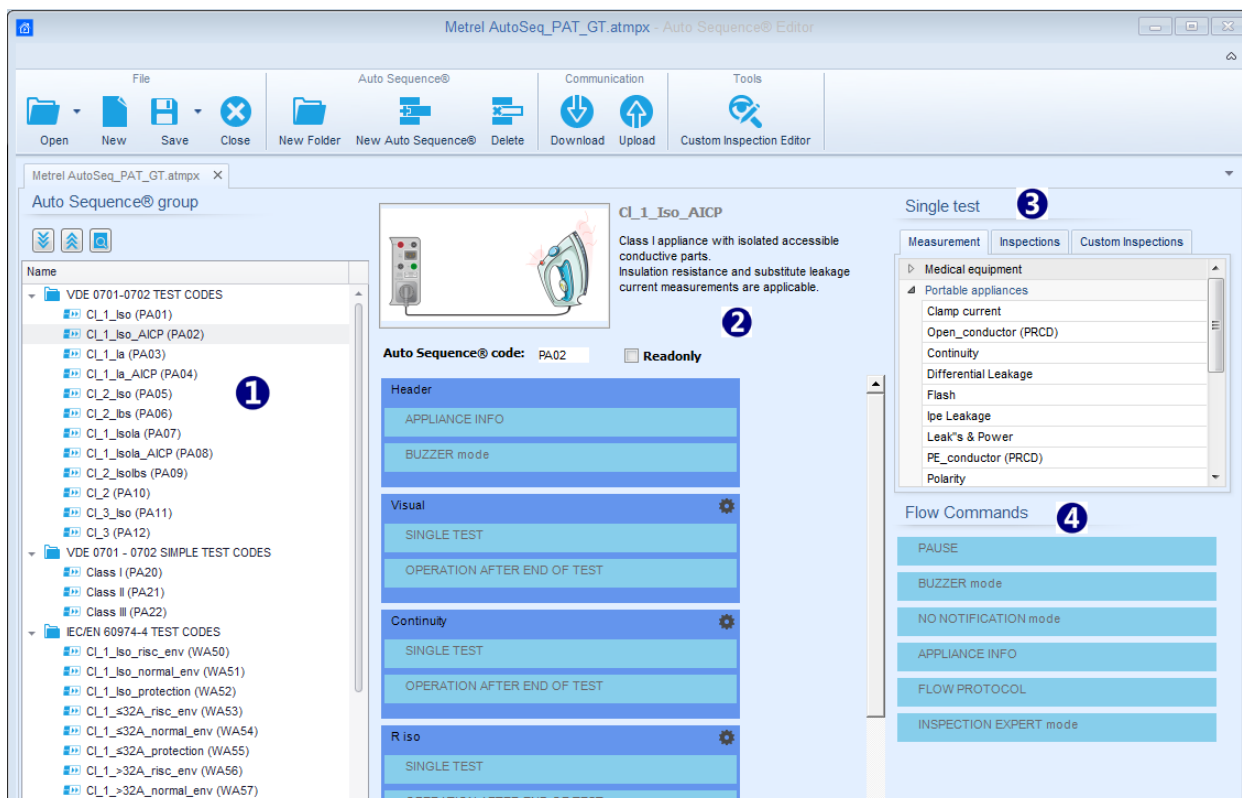

Figure E.1: Auto sequence® editor workspace

An Auto Sequence® **2** begins with Name, Description and Image, followed by the first step (Header), one or more measuring steps and ends with the last step (Result). By inserting appropriate Single tests (measurements, inspections and custom inspections) **3** and Flow commands **4** and setting their parameters, arbitrary Auto Sequences® can be created.



Figure E.2: Example of an Auto Sequence® header

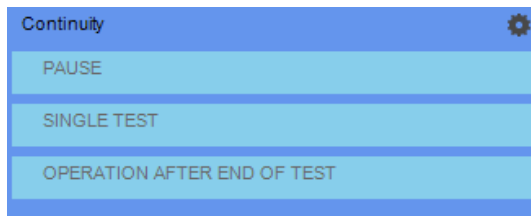

Figure E.3: Example of a measurement step



Figure E.4: Example of an Auto Sequence® result

E.2 Managing groups of Auto Sequences®

The Auto Sequences® can be divided into different user defined groups of Auto Sequences®. Each group of Auto Sequences® is stored in a file. More files can be opened simultaneously in Auto Sequence® editor.

Within Group of Auto Sequences®, tree structure can be organized, with folders / subfolders containing Auto Sequences®. The three structure of currently active Group of Auto Sequences® is displayed on the left side of the Auto Sequence® editor workspace, see **Figure E.5**.

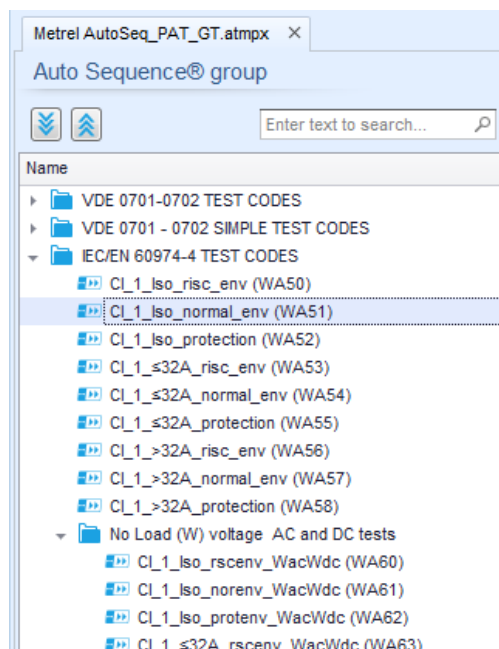









Figure E.5: Group of Auto Sequences® tree organization

Operation options on Group of Auto Sequences® are available from menu bar at the top of Auto Sequence® Editor workspace.

File operation options:



	Opens a file (Group of Auto Sequences®).
	Creates a new file (Group of Auto Sequences®).
	Saves / Saves as the opened Group of Auto Sequences® to a file.
	Closes the file (Group of Auto Sequences®).

Group of Auto Sequences® view options:





	Expand all folders / subfolders / Auto Sequences®.
	Collapse all folders / subfolders / Auto Sequences®.
	Search by name within Auto Sequence® group. See <i>Appendix E.2.2 Search within selected Auto Sequence® group</i> for details.

Group of Auto Sequences® operation options



(also available by right clicking on Folder or Auto Sequence®):

	Adds a new folder / subfolder to the group
	Adds a new Auto Sequence® to the group.
	Deletes: <ul style="list-style-type: none"> › the selected Auto Sequence® › the selected folder with all subfolders and Auto Sequences®



Right click on the selected Auto Sequence® or Folder opens menu with additional possibilities:

	Auto Sequence®: Edit Name, Description and Image (see <i>Figure E.6</i>). Folder: Edit folder name
	Auto Sequence®: Copy to clipboard Folder: Copy to clipboard including subfolders and Auto Sequences®
	Auto Sequence®: Paste it to selected location Folder: Paste it to selected location
	Auto Sequence®: Creates shortcut to selected Auto Sequence®

Double click on the object name allows it name edit:

DOUBLE CLICK	<p>Auto Sequence® name: Edit Auto Sequence® name</p> <p> New Auto Sequence®</p> <p>Folder name: Edit folder name</p> <p> Portable / Handheld Equipment</p>
--------------	--

Drag and drop of the selected Auto Sequence® or Folder/Subfolder moves it to a new location:

<p>DRAG & DROP</p>	<p>“Drag and drop” functionality is equivalent to “cut” and “paste” in a single move.</p> <p> move to folder</p> <p> insert</p>
------------------------	---



E.2.1 Auto Sequence® Name, Description and Image editing

When EDIT function is selected on Auto Sequence®, menu for editing presented on **Figure E.6** appear on the screen. Editing options are:

Name: Edit or change the name of Auto Sequence®.

Description: Any text for additional description of Auto Sequence® can be entered.

Image: Image presenting Auto sequence® measuring arrangement can be entered or deleted.

	<p>Enters menu for browsing to Image location.</p>
	<p>Deletes the Image from Auto Sequence®.</p>

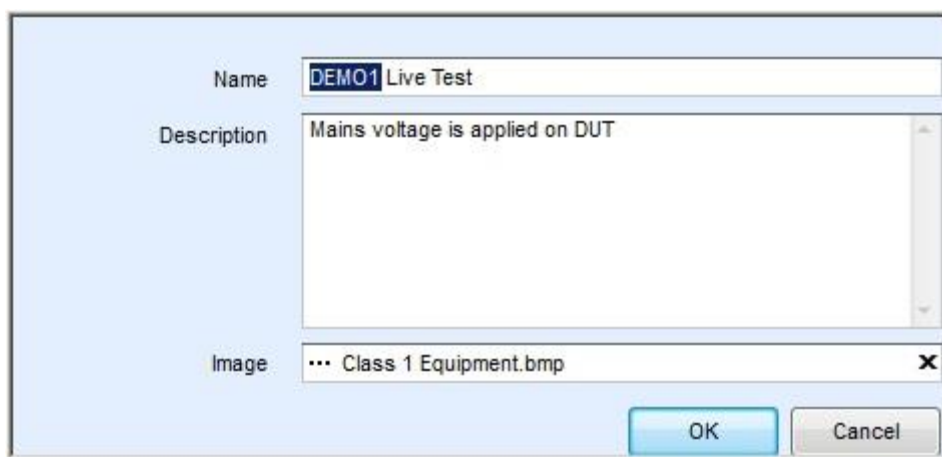





Figure E.6: Editing the Auto Sequence® Name, Description and Image

E.2.2 Search within selected Auto Sequence® group

By entering the text into search box and click on the search  icon, found results are highlighted with yellow background and first found result (Folder or Auto Sequence®) is focused.

Click on the Search icon  again focus next search result. Search functionality is implemented in Folders, Subfolders and Auto Sequences® of selected Auto Sequence® Group.

Search text can be cleared by selecting the Clear  button.

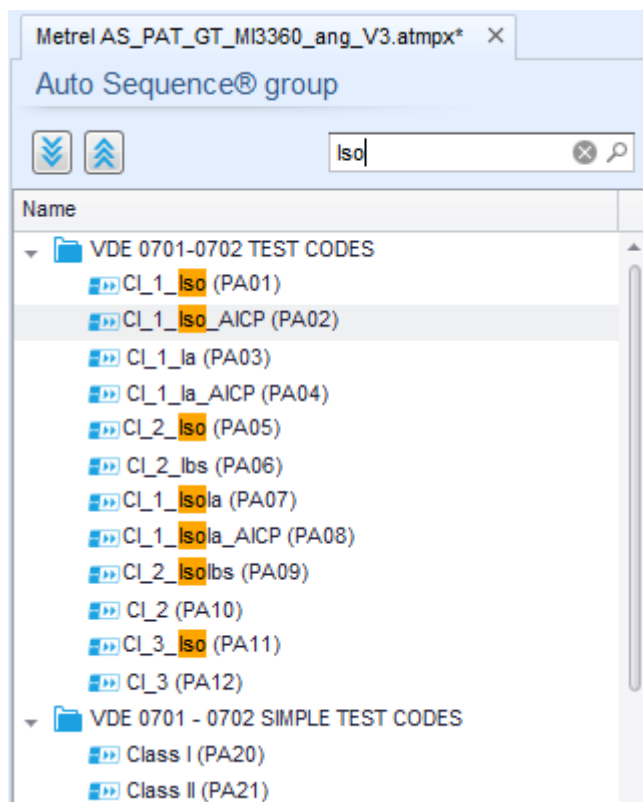

Figure E.7: Example of Search result within Auto Sequence® group

E.3 Elements of an Auto Sequence®

E.3.1 Auto Sequence® steps

There are three kinds of Auto Sequence® steps.

Header

The Header step is empty by default.

Flow commands can be added to the Header step.

Measurement step

The Measurement step contains a Single test and the Operation after end of test flow command by default. Other Flow commands can also be added to the Measurement step.

Result

The Result step contains the Result screen flow command by default. Other Flow commands can also be added to the Result step.

E.3.2 Single tests

Single tests are the same as in Metrel ES Manager Measurement menu.

Limits and parameters of the measurements can be set. Results and sub-results can't be set.

E.3.3 Flow commands

Flow commands are used to control flow of the measurements. Refer to chapter **E.5 Description of flow commands** for more information.

E.3.4 Number of measurement steps



Often the same measurement step has to be performed on multiple points on the device under test. It is possible to set how many times a Measurement step will be repeated. All carried out individual Single test results are stored in the Auto Sequence[®] result as if they were programmed as independent measuring steps.

E.4 Creating / modifying an Auto Sequence[®]

If creating a new Auto Sequence[®] from scratch, the first step (Header) and the last step (Result) are offered by default. Measurement steps are inserted by the user.

Options:

Adding a measurement step	By double clicking on a Single test a new measurement step will appear as the last of measurement steps. It can also be dragged and dropped on the appropriate position in the Auto Sequence [®] .
Adding flow commands	Selected flow command can be dragged from the list of Flow commands and dropped on the appropriate place in any Auto Sequence [®] step.

Changing position of flow command within measurement step	By a click on an element and use of  keys.
Viewing / changing parameters of flow commands or single tests.	By a double click on the element.
Setting number of measurement step repetitions	By setting a number in the  field

Right click on the selected measurement step / flow command:

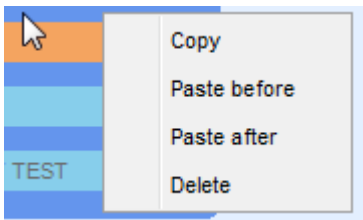
	<p>Copy – Paste before A measurement step / flow command can be copied and pasted above selected location on the same or on another Auto Sequence[®].</p> <p>Copy – Paste after A measurement step / flow command can be copied and pasted under selected location on the same or on another Auto Sequence[®].</p> <p>Delete Deletes the selected measurement step / flow command.</p>
---	---

E.5 Description of flow commands

Double click on inserted Flow Command opens menu window, where text or picture can be entered, external signalling and external commands can be activated and parameters can be set.

Flow commands Operation after end of test and Results screen are entered by default, others are user selectable from Flow Commands menu.

Pause

A Pause command with text message or picture can be inserted anywhere in the measuring steps. Warning icon can be set alone or added to text message. Arbitrary text message can be entered in prepared field Text of menu window.

Parameters:

Pause type	Show text and/or warning (<input checked="" type="checkbox"/> check to show warning icon) Show picture ( browse for image path)
Duration	Number in seconds, infinite (no entry)

Output state

Sets outputs OUT_1, OUT_2, OUT_3, and OUT_4 on OUTPUTS port.

Following settings of this command are ignored:

- OUT_1 and OUT_2 while Lamps HV mode is enabled.
- OUT_3 and OUT_4 while Lamps Pass / Fail mode is enabled.

All outputs are single normally opened relay contacts if not checked in Menu Output pins window.

Parameters:

<input checked="" type="checkbox"/> OUT_1	Set closed relay contact between OUTPUTS pins 4 and 9
<input checked="" type="checkbox"/> OUT_2	Set closed relay contact between OUTPUTS pins 3 and 8
<input checked="" type="checkbox"/> OUT_3	Set closed relay contact between OUTPUTS pins 2 and 7
<input checked="" type="checkbox"/> OUT_4	Set closed relay contact between OUTPUTS pins 1 and 6
<input checked="" type="checkbox"/> OUT_5 <input checked="" type="checkbox"/> OUT_6 <input checked="" type="checkbox"/> OUT_7 <input checked="" type="checkbox"/> OUT_8	Applicable only when using CE Adapter A 1460

Wait input mode

Reads input condition on pins IN_2, IN_3, IN_4 and IN_5 on INPUTS port. Input must be high to proceed with the Auto test.

Parameters

State	On – enables Wait input mode; set active INPUTS from Input pins menu
-------	--

	Off – disables Wait input mode
<input checked="" type="checkbox"/> IN_2	IN_2 reading condition on INPUTS pin 6 is active
<input checked="" type="checkbox"/> IN_3	IN_3 reading condition on INPUTS pin 7 is active
<input checked="" type="checkbox"/> IN_4	IN_4 reading condition on INPUTS pin 8 is active
<input checked="" type="checkbox"/> IN_5	IN_5 reading condition on INPUTS pin 4 is active

Lamps HV mode

Drives external lamps through OUT_1 and OUT_2 outputs. Works only in HV & HV programmable functions.

- › Green lamp (OUT_2) ON means that the instrument is ready for HV test. Green lamp turns on before first flow command in step that contains HV test. It remains ON, if input conditions are not fulfilled to start the HV measurement. Green lamp turns off during HV measurement and after end of the HV test.
- › Red lamp (OUT_1) ON means that dangerous voltage is present at WITHSTANDING (HV) test terminals. Red lamp turns on before the measurement and turns off after the measurement.

While Lamps HV mode command is enabled the settings of Drive output command for OUT_1 and OUT_2 is ignored.

Parameters

State	On – enables Lamps HV mode Off – disables Lamps HV mode
-------	--

Lamps Pass / Fail mode

Drives external lamps through OUT_3 and OUT_4 outputs.

During measurement the lights reflect status icon in single test.

After measurement

- › Blue lamp (OUT_3) lights ON when test has passed. Lamp is lit until next step is started.
- › Yellow lamp (OUT_4) lights ON when test has failed. Lamp is lit until next step is started.
- › Lights turn off at the beginning of next step.

While Lamps Pass / Fail mode command is enabled the settings of Drive output command for OUT_3 and OUT_4 is ignored.

Parameters

State	On – enables Lamps Pass / Fail mode Off – disables Lamps Pass / Fail mode
-------	--

Buzzer mode

Passed or failed measurement is indicated with beeps.

- › Pass – double beep after the test
- › Fail – long beep after the test

Beep happens right after single test measurement.

Parameters

State	On – enables Buzzer mode Off – disables Buzzer mode
-------	--

External TEST / OK key mode

Instrument enables external TEST / OK key (OK / ENTER / TEST / HV TEST) by activating INPUT pin 5 reading condition. Functionality of the EXTERNAL OK KEY mode is the same as of the OK / ENTER / TEST / HV TEST key and is used for pedal / commander operation.

Parameters

State	On – enables External TEST / OK key mode (INPUT pin 5 is active) Off – disables External TEST / OK key mode
-------	--

No notifications mode

Instrument skips pre-test warnings (see chapter **4.5 Symbols and messages** for more information).

Parameters

State	On – enables No notifications mode Off – disables No notifications mode
-------	--

Appliance info

Instrument enables to automatically add the appliance name to the Auto Sequence®.

Parameters

Repeat Setting	Repeat:	The same Appliance ID will be offered each time if the same Auto test is carried out successively in a loop.
	Increment:	A four-digit number will be added to the Appliance ID and incremented each time if the same Auto Sequence® is carried out successively in a loop.
Appliance type	Selects the type of the appliance (Appliance, Appliance_FD, Welding equip., Welding equip. FD)	
Default Appliance ID	Enter default Appliance ID	
Appliance name	Enter Appliance name. Options: <input checked="" type="checkbox"/> Editable – allows Appliance name to be modified while running Auto Sequence®. Menu with a list of Appliance names and possibility to enter custom Appliance name is offered within the test. <input type="checkbox"/> Not editable – Default Appliance name is used. Appliance name cannot be modified while running Auto Sequence®.	
Retest period	Retest period in months. Options: <input checked="" type="checkbox"/> Editable – allows Retest period to be modified while running Auto Sequence®. Numeric keypad for entering custom Retest period is offered within the test. <input type="checkbox"/> Not editable – Default Retest period is used. Retest period cannot be modified while running Auto Sequence®.	

Note

- This flow command is active only if Auto Sequence® is started from the Auto Sequences® Main menu.

Inspection Expert mode

If Inspection Expert mode flow command is set, the Visual inspection screen and Functional inspection screen within Auto Sequence® are displayed for 1 second and an overall PASS is automatically applied at the end of test. In between, the automatic procedure can be stopped and statuses can be applied manually.

Inspection Expert mode is disabled by default.

Parameters

State	On – enables automatic settings of tickers in Visual and Functional tests. Off – disables automatic settings of tickers in Visual and Functional tests.
-------	--

Operation after end of test

This flow command controls the proceeding of the Auto Sequence® in regard to the measurement results.

Parameters

Operation after end of test – pass – fail – no status	The operation can be individually set for the case the measurement passed, failed or ended without a status.	
	Manual:	The test sequence stops and waits for appropriate command (ENTER key, external command...) to proceed.
	Auto:	The test sequence automatically proceeds.

Result screen

This flow command controls the proceeding after the Auto Sequence® has ended.

Parameters

<input checked="" type="checkbox"/> Auto Save	Auto Sequence® results are stored in the momentary workspace. A new Node with the date and time will be created. Under the Node Auto Sequence® results or (if Appliance info flow command is set) a new appliance and Auto Sequence® results will be stored. Up to 100 Auto Sequence® results or appliances can be automatically stored under the same node. If more results / appliances are available, they are split to multiple nodes. Local Save Flow setting is disabled by default.
<input checked="" type="checkbox"/> Auto Print	Auto Sequence® results are automatically printed.

Note

- This flow command is active only if Auto Sequence® is started from the Auto Sequences® Main menu (not from Memory organizer).

E.6 Custom Inspections programming

Arbitrary set of tasks dedicated to specific user defined Inspections can be programmed with application of Custom Inspection Editor Tool, accessible from Auto Sequence® Editor workspace. Custom Inspections are stored in dedicated file *.indf with user defined name. For application of Custom Inspections as a single test within Auto Sequence® group, appropriate file containing specific Custom Inspection should be opened first.

E.6.1 Creating and editing Custom Inspections

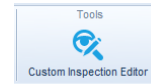

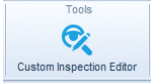
Custom Inspection Editor workspace is entered by selecting  icon from Auto Sequences® main menu. It is divided in two main areas, as presented on **Figure E.8**:

- 1 Custom Inspection **Name** and **Scope** of inspection (Visual or Functional)
- 2 **Name** of Custom Inspection Item tasks and **Type** of Item Pass / Fail checkbox marking

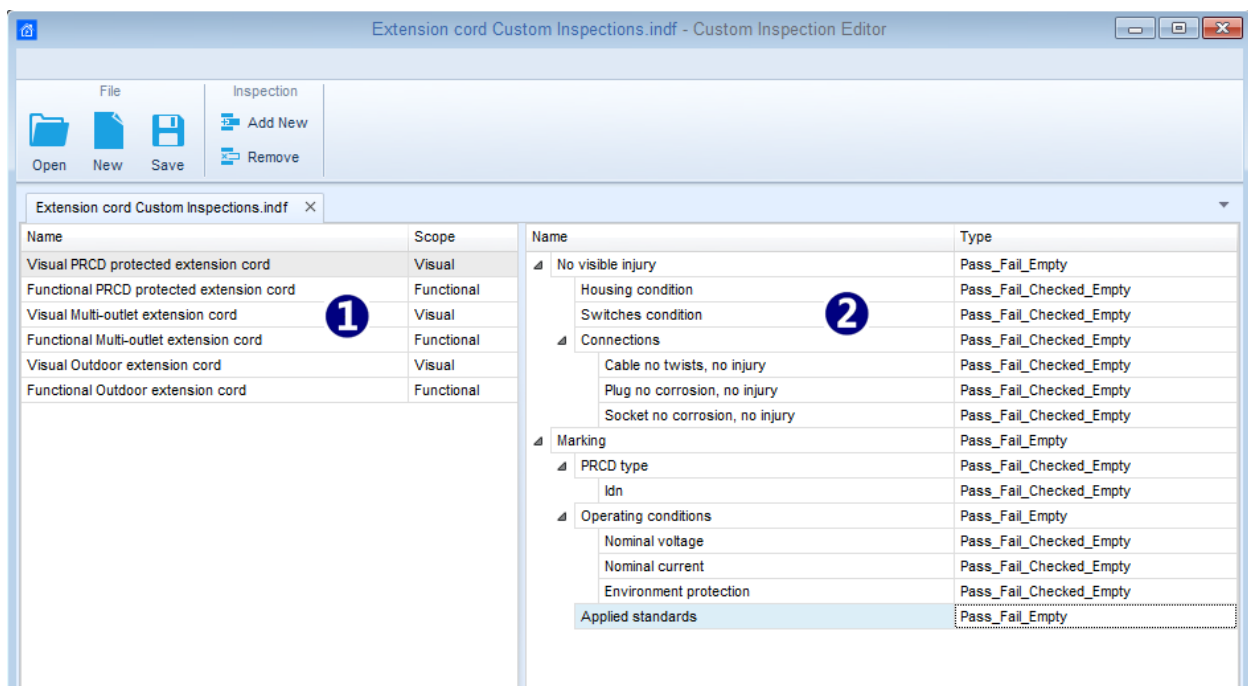

Figure E.8: Custom Inspection Editor workspace

Custom Inspection Editor Main menu options:



Opens existing Custom Inspection Data file.
By selecting, menu for browsing to location of *.indf file containing one or more Custom Inspections data appear on the screen. Selected file is opened in dedicated tab marked with file name.



Creates a new Custom Inspection Data file.
New tab with empty workspace is opened. Default name of the new tab is *Inspection Data File*; it could be renamed during Save procedure.



Saves / Saves as Custom Inspection Data file opened on active tab.
Menu for browsing to the folder location and editing of file name is opened.
Browse to the location, confirm overwriting, if file already exists or edit file name to

save it as a new Custom Inspection Data file.

Add New Custom Inspection.



New inspection with default name *Custom Inspection* and default scope *Visual* appear on the editor workspace. It contains one Item task with default name *Custom Inspection* and default Type *Pass_Fail_Checked_Empty*. Default Name and Type can be edited – changed.



Remove selected custom inspection.

To select inspection, click to the inspection Name field. To remove it, select icon from editor main menu. Before removal, user is asked to confirm deletion.

Edit Name and Scope of Inspection

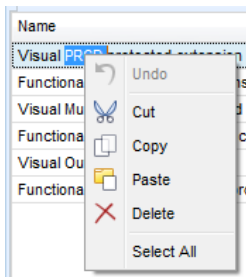

Inspection Name edit:

Click to the Inspection Name field to start editing it.
 Drag cursor, with left mouse button pressed, to select letters and words.
 Position cursor and double-click to select word of the name. Actions could be performed with keyboard also.
 Press right mouse button to activate Edit menu and select appropriate action as presented on the left figure. Menu is case sensitive; options currently not available are greyed out.

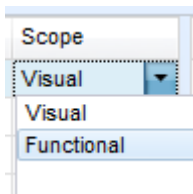

Inspection Scope edit:

Click to Inspection Scope field to open selection menu presented on left figure. Options:
Visual is intended for observation of test object
Functional allows functional test of observed object

Edit Item task structure of Inspection

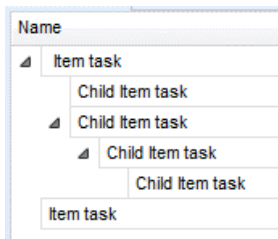

Item tasks of the selected Inspection are listed in Name column on the right side of Editor workspace.
 Each Item task can have Child Item tasks, Child Item can have its own Child Item tasks and so on.
 Arbitrary tree structure of Item tasks and subtasks can be built as presented on left figure.

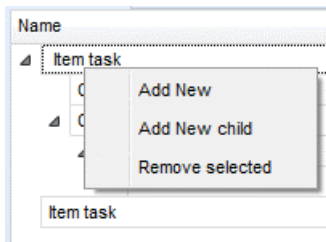

ADD New Item task procedure:

Position cursor above Item task Name and apply right mouse click to select Item task and open menu with options:
Add New: new Item task is added on the top tree level
Add New Child: new child Item task is added under selected Item
Remove selected: delete selected Item task with all subtasks
 Default Name of New Item task is *Custom Inspection*, default Type *Pass_Fail_Checked_Empty* and both can be edited – changed.

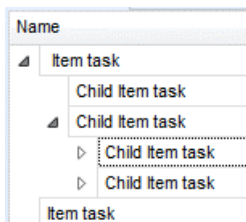

Item tasks containing Child Item tasks are marked with triangle in front of their Name.
 Click on triangle mark:
 ▾ collapse Item task tree structure
 ▸ expands Item task tree structure

Edit Name and Type of Item task

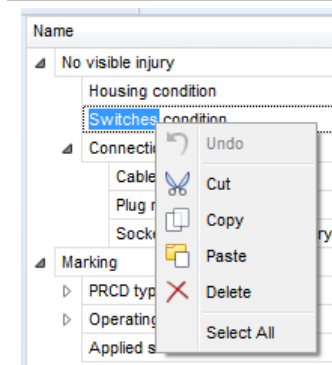

Edit Name of Item task:

Click to the Item task Name field to start editing it. Drag cursor, with left mouse button pressed, to select letters and words. Position cursor and double-click to select word of the name. Actions could be performed with keyboard also. Press right mouse button to activate Edit menu and select appropriate action as presented on the left figure. Menu is case sensitive; options currently not available are greyed out.

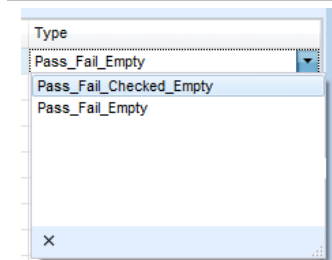

Edit Type of Item task:

Click to Item Type field to open selection menu presented on left figure. Selectable checkbox status assignment options are:
Pass_Fail_Checked_Empty: Pass, Fail, Checked, Empty (default)
Pass_Fail_Empty: Pass, Fail selection, Empty (default) value

E.6.2 Applying Custom Inspections

Custom inspections can be applied in Auto Sequences®. Direct assignment of Custom inspection to the Metrel ES manager structure objects is not possible. After custom created Inspection Data file is opened, available inspections are listed in Custom Inspections tab of Single test area of Auto Sequence® editor, see chapter **E.1 Auto Sequence® editor workspace** for details. Custom Inspection is added to Auto sequence as a Single test, see chapter **E.4 Creating / modifying an Auto Sequence®** for details.

Opening / changing Inspection Data File

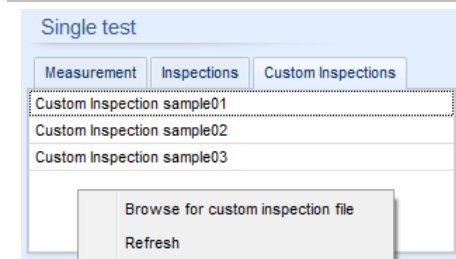

Position cursor within Custom inspections List area and apply mouse right click to open Option menu:
Refresh: Refresh content of already opened Inspection Data file.
Browse for custom Inspection file: Menu for browsing to folder location of new Inspection Data file is opened.

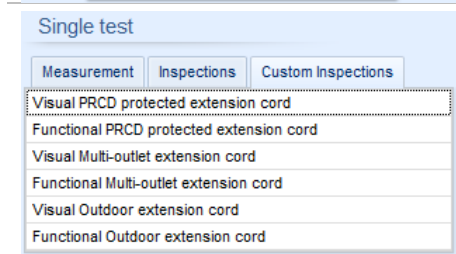

After confirmation of selection, new Inspection Data file is opened and list of available Custom Inspections is changed.
Note:
 › If Metrel ES Manager Work scope is changed, opened Inspection Data file remains active and available Custom Inspections remains the same.